

INTERNATIONAL LASER RANGING SERVICE

2007–2008

R E P O R T

November 2009

Edited by C. Noll and M. Pearlman

NASA/TP-2009-215848

2007-2008

R E P O R T

November 2009

Edited by C. Noll and M. Pearlman

Available From:

NASA Center for Aerospace Information
7121 Standard Drive
Hanover, MD 21076-1320
Price Code: A17

National Technical Information Service
5285 Port Royal Road
Springfield, VA 22161
Price Code: A10

PREFACE

This 2007-2008 volume is the sixth published report for the International Laser Ranging Service (ILRS). This edition once again concentrates on achievements and work in progress rather than ILRS organizational elements. The 2007-2008 ILRS report is structured as follows

- Section 1 – ILRS Organization, reviews the service and its role in space geodesy.
- Section 2 – ILRS Tracking Network, provides the current status and recent performance statistics of the international stations supporting the ILRS and offers a perspective on site surveys and system co-locations. An update on field engineering activities is also provided.
- Section 3 – ILRS Missions and Campaigns, gives information about many of the current and future missions supported by the ILRS.
- Section 4 – Infrastructure, details recent activities tackled by the ILRS Central Bureau, including Web site improvements and data center developments.
- Section 5 – Tracking Procedures and Data Flow, discusses satellite predictions, ILRS tracking priorities, recent developments in the area of dynamic priorities, and the flow of on-site normal points and full-rate data.
- Section 6 – Emerging Technologies, includes information about high repetition rate lasers and systems, detectors, timers and frequency standards, multi-wavelength ranging, and other hardware that will help advance the accuracy and automation of laser ranging systems. Also included are new applications for the SLR technique.
- Section 7 – Analysis Activities, reviews the recent developments in the ILRS Analysis Working Group and plans for future products.
- Section 8 – Modeling, discusses recent advancements in refraction modeling and satellite center of mass corrections.
- Section 9 – Science Report examines the ILRS role in the ITRF, its synergy with the other geodetic techniques, and some interesting applications for both SLR and LLR.
- Section 10 – Meetings and Reports, reviews ILRS-related meetings in 2007-2008 and reports issued by the service over that period.
- Section 11 – Bibliography, lists some of the papers and presentations about SLR and LLR science and technology made during 2007-2008.
- Section 12 – AC, AAC and Lunar AAC Reports, presents individual summaries from ILRS analysis, associate analysis, and lunar associate analysis centers.
- Section 13 – Station Reports, includes information received from the stations contributing to the ILRS network.
- Appendix – ILRS Information, lists organizations participating in the ILRS and defines acronyms used in this report.

This report is also available through the ILRS Web site at URL
http://ilrs.gsfc.nasa.gov/reports/ilrs_reports/ilrsreport_2007.html.

For further information, contact the ILRS Central Bureau:

Carey Noll
Secretary, ILRS Central Bureau
NASA Goddard Space Flight Center
Code 690.1
Greenbelt, MD 20771
USA
Carey.Noll@nasa.gov

Michael Pearlman
Director, ILRS Central Bureau
Harvard/Smithsonian Center for Astrophysics
60 Garden Street
Cambridge, MA 02138
USA
mpearlman@cfa.harvard.edu

ILRS Web site: <http://ilrs.gsfc.nasa.gov>

A complete list of ILRS associates can be found on the ILRS Web site at
http://ilrs.gsfc.nasa.gov/contact_ilrs/ilrs_directory.html.

ACKNOWLEDGEMENT

The editors would like to acknowledge the essential contributions from our ILRS colleagues to this 2007-2008 edition of the ILRS report.

TABLE OF CONTENTS

Preface	i
Acknowledgement	iii
Dedication	1
Introduction	3
Chairman's Remarks	5
Section 1 – ILRS Organization	1-1
Section 2 – ILRS Tracking Network	2-1
Section 3 – ILRS Missions and Campaigns	3-1
Section 4 – Infrastructure	4-1
Section 5 – Tracking Procedures and Data Flow	5-1
Section 6 – Emerging Technologies	6-1
Section 7 – Analysis Activities	7-1
Section 8 – Modeling	8-1
Section 9 – Science Report	9-1
Section 10 – Meetings	10-1
Section 11 – Bibliography	11-1
Section 12 – Analysis Center, Associate Analysis Center, and Lunar Associate Analysis Center Reports	12-1
<i>Analysis Center Reports</i>	12-1
Italian Space Agency/Space Geodesy Center “G. Colombo” (ASI/CGS)	12-1
Bundesamt für Kartographie und Geodäsie (BKG)	12-5
Deutsches Geodätisches Forschungsinstitute (DGFI)	12-7
Geoscience Australia (GA)	12-10
Helmholtz Centre Potsdam GeoForschungsZentrum German Research Centre for Geosciences (GFZ) ..	12-12
Groupe de Recherche en Geodesie Spatiale (GRGS)	12-14
Joint Center for Earth Systems Technology/Goddard Space Flight Center (JCET/GSFC)	12-16
Natural Environment Research Council (NERC) Space Geodesy Facility (NSGF)	12-22
<i>Associate Analysis Center Reports</i>	12-25
Center for Orbit Determination in Europe (CODE)	12-25
The University of Texas Center for Space Research (CSR)	12-27
Delft University of Technology (DUT)	12-31
European Space Operation Centre (ESOC)	12-33
Forsvarets Forskningsinstitut (FFI)	12-35
Main Astronomical Observatory of the National Academy of Sciences of Ukraine (GAOUA)	12-37
Hitotsubashi University	12-40

Institute of Applied Astronomy (IAA)	12-42
Information-Analytical Center (IAC), formerly Mission Control Center (MCC)	12-44
Japan Aerospace Exploration Agency (JAXA)	12-46
Newcastle University	12-49
National Institute of Information and Communications Technology (NICT)	12-50
Shanghai Astronomical Observatory (SHAO)	12-52
<i>Lunar Associate Analysis Center Reports</i>	12-54
Institut Fuer Erdmessung/Forschungseinrichtung Satellitengeodaesie (IFE/FESG)	12-54
Jet Propulsion Laboratory (JPL)	12-57
Paris Observatory Lunar Analysis Center (POLAC)	12-59
Section 13 – Station Reports	13-1
Arequipa, Peru	13-1
Beijing, China	13-4
Borowiec, Poland	13-7
Changchun, China	13-10
Concepción, Chile	13-13
FTLRS, France	13-16
Grasse, France	13-18
Graz, Austria	13-20
Greenbelt MD (MOBLAS-7), USA	13-23
Greenbelt MD (NGSLR), USA	13-25
Haleakala HI, USA	13-27
Hartebeesthoek, South Africa	13-29
Helwan, Egypt	13-31
Herstmonceux, UK	13-34
Kiev, Ukraine	13-37
Kunming, China	13-39
Lviv, Ukraine	13-41
Matera, Italy	13-44
McDonald TX, USA	13-47
Metsahovi, Finland	13-50
Monument Peak CA, USA	13-52
Mount Stromlo, Australia	13-54
Potsdam, Germany	13-57
Riga, Latvia	13-58
Riyadh, Saudi Arabia	13-61
San Fernando, Spain	13-63
San Juan, Argentina	13-65
Shanghai, China	13-68
Simeiz, Ukraine	13-71
Simosato, Japan	13-73



Tanegashima, Japan	13-74
Wetzell, Germany	13-76
Yarragadee, Australia	13-78
Zimmerwald, Switzerland	13-80
Appendix – ILRS Information	A-1
ILRS Organizations	A-1
Acronyms	A-3

DEDICATION



*Professor Dr. Werner Gurtner, 1949-2009
Astronomical Institute of Bern, Switzerland*

It is with deep sadness that the ILRS community learned of the death of Prof. Dr. Werner Gurtner from cancer on October 24, 2009 shortly after his sixtieth birthday.

Werner Gurtner completed his studies in Surveying Engineering in 1973 at the Institute of Geodesy and Photogrammetry of the ETH in Zurich, Switzerland. From 1974 to 1979 he was a research assistant and Ph.D. candidate with Prof. Max Schuerer, who was a lecturer at the ETH in addition to his position as director of the AIUB. Werner's Ph.D. thesis, partly written in Bern, resulted in a well-known reference, the "Geoid of Switzerland" using astrometric observations.

Werner started his official employment with the AIUB in January 1980. As early as 1978, at the ETH, he started work on the new Zimmerwald observatory, dedicated to Satellite Laser Ranging (SLR) and in 1987 he became the director of the Zimmerwald Fundamental Observatory. Between 1992 and 1996 he led the AIUB team, which planned and realized the new SLR and astrometry telescope in Zimmerwald. In collaboration with the Canton of Bern, the University of Bern, the Swiss National Science Foundation, and the Swiss Federal Office of Topography, the one-meter combined SLR and astrometry telescope was deployed at Zimmerwald and became one of the essential pillars of the International Laser Ranging Service (ILRS). With this same energy, Werner organized the upgrade of the observatory during 2005-2008. This upgrade included a new laser capable of performing dual-color measurements as well as supporting future one-way ranging and transponder experiments. The Zimmerwald Observatory as established by Werner is recognized now as one of the foremost stations in the global space geodesy community from the scientific, technical, and administrative points of view.

During the 1980's Werner also worked on the team that successfully developed what would eventually be known as the Bernese GPS Software package. In the 1990's, he was one of the key persons in the development of the International GNSS Service (IGS). His contributions related to IGS data transfer and information dissemination were of great importance and at least in part responsible for the worldwide acceptance of the IGS. The Receiver INdependent EXchange (RINEX) format, which he initiated and coined to a great extent, became a standard as the platform for exchanging GNSS data in both science and engineering applications. Werner continued to work on enhancements to RINEX until very recently. The global acceptance of RINEX in both the science and receiver technology communities is a tribute to Werner's foresight.

Werner helped the International Association of Geodesy (IAG) to develop essential structural elements related to space geodesy. He was a member of the very active EUREF Technical Working Group since 1992; he chaired this group from 1999 to 2003. He was not only a key person on the development of the IGS, but also, even to a much greater extent, for the development of the ILRS. Werner Gurtner was a member of the ILRS Governing Board since its inception in 1998 and served as Chair of the Board from 2002 to 2009. Before that time he chaired EUROLAS, an association of European SLR observatories. Werner was an important link between the various space geodesy communities, particularly the ILRS and IGS.

The Faculty of Sciences of the University of Bern acknowledged the achievements of this eminent engineer and scientist by awarding him the title of professor in 1999. Werner Gurtner will be remembered as competent collaborator, good friend and dear colleague.

The ILRS would like to dedicate this issue of the report series to the memory of our colleague, Professor Dr. Werner Gurtner, in grateful recognition of his many contributions to SLR and GNSS, the ILRS and the IGS, and the broader international space geodesy community. We all will miss our association and interactions with Werner.

Michael Pearlman, Harvard-Smithsonian Center for Astrophysics, USA
Gerhard Beutler, Astronomical Institute University of Bern, Switzerland

INTRODUCTION

THE INTERNATIONAL LASER RANGING SERVICE 2007-2008

In August, 1969, NASA convened a 10-day seminar at Williams College, Williamstown, Massachusetts. The seminar was chaired by William Kaula and attended by other visionaries in the emerging discipline of satellite geodesy. A report of the discussions and deliberations was produced: "The Terrestrial Environment: Solid Earth and Ocean Physics," NASA CR-1579, April, 1970, which became known as "The Williamstown Report."

It was an exciting time in August, 1969, with the first successful Apollo landing on the Moon in July and return of the Apollo-11 astronauts to Earth. The astronauts had deployed reflector arrays to enable studies of the lunar orbital and rotational motion with unprecedented accuracy using the new laser ranging technology, already demonstrated in 1964 with Earth satellites. In fact, initial laser returns from the Apollo-11 reflectors were obtained in August just before and during the Williamstown meeting.

The Williamstown Report acknowledged the importance of laser ranging: "There is no doubt that laser ranging will be a basic technique in any future system that requires maximum accuracy" (page 2-7). And indeed it is the case that laser ranging to artificial satellites and the Moon have been essential contributors to the science described in the Williamstown Report.

It was recognized very early that laser tracking of artificial satellites and the Moon would benefit from a global distribution of instruments, especially to support applications of the technique to investigate global phenomena, such as distribution of mass within the Earth (gravitational field) and three-dimensional motion of the Earth and Moon in space. With this recognition, the community organized itself, somewhat informally, to build a global network of SLR and LLR stations. This network of stations played key roles in the missions of several satellites, including satellites specifically designed to operate with laser ranging (such as the Laser Geodynamics Satellite, LAGEOS) and radar altimeter satellites that carried retroreflector arrays (such as GEOS-C, Seasat and TOPEX/Poseidon). The informal network was accomplished through the gracious collaboration of institutions and government agencies of several nations. This collaboration, which is now formalized into the International Laser Ranging Service, continues to provide key functions and services to the global geodetic and geophysical community. In the more than forty years that have elapsed since the first experiments on laser ranging to an artificial satellite (Beacon Explorer-B), the ILRS has matured into a global network that provides vital support to missions. The international collaboration has been crucial to the success and the sharing of the cost among the various institutions and agencies has been essential for the network growth.

The ILRS roots can be traced to the first laser ranging experiments on BE-B, but the ILRS now provides tracking support of numerous satellites and the list continues to grow. It is always a pleasure to acknowledge the many dedicated contributors to the ILRS. The tracking of the variety of satellites is not only much appreciated, it is essential for the scientific application (and in some cases, the technological applications) of those satellites.

Although the role of laser ranging has changed over the years, it is still the premier technique for aspects of the reference frame and for providing an absolute measure of accuracy. Today, SLR is used as the sole source of tracking on some satellites, such as LAGEOS and Starlette, but SLR also provides an essential role of validating the orbit determination based on other techniques, such as GPS.

The future for laser ranging is bright, with new technology and applications not envisioned by the Williamstown Report. The technology has emerged in the form of laser altimetry of the Earth, Moon, and Mars. And one-way ranging experiments are planned from the Earth to lunar satellites, for example. Once again, it is an exciting time as we watch

these new technologies and applications move toward fruition. Nevertheless, we cannot neglect our core activities and responsibilities. We must continue to improve the instrumentation by lowering operating costs and improving accuracy. The laser ranging community continues to be a vibrant and innovative international collaboration of individuals and institutions, and on behalf of the community of users of laser ranging data, I offer the sincere thanks from the user community for your dedication to laser ranging.

I was asked the following questions some years ago: how long do we need to continue tracking LAGEOS? Have we already extracted all the information about the LAGEOS dynamics and various applications of LAGEOS that we can and therefore, there is no need to continue tracking? These are certainly thought provoking and valid questions. It is amazing to me, that after more than thirty years, LAGEOS and Starlette, for example, continue to be orbiting benchmarks. SLR now has the longest time history of high accuracy observations of artificial satellites. We are still learning about long-term satellite dynamics, i.e., orbit evolution, the reference frame and the environment in which the satellite moves. And these satellites and their applications still have a lot to teach us. As long as we continue to learn, I would argue that we should continue tracking such satellites. As of now, we continue to learn.

Bob E. Schutz
Austin, Texas
November 2, 2009

CHAIRMAN'S REMARKS

The bi-annual report is an opportunity for the ILRS to provide the community with the update on the Service activities, procedures and plans. The report also gives each of the ILRS entities the occasion to include news on recent activities and to bring us up to date on staff changes. The report also includes station performance information and activities underway that will improve performance in the future. This report period includes some rather fundamental changes and some new challenges for the ILRS.

Network data yield continues to increase. The stations in Arequipa and Haleakala are now operational and data yield on GNSS satellites has improved. Daylight tracking, particularly on the higher satellites is still a major issue on the higher satellites, but some of the stations have had success with daylight ranging on some of the GNSS satellites as technology has improved with the higher repetition rate lasers and tracking techniques have been refined. One disappointment during this period was discovery of small range biases, some being introduced by the Stanford Counter that have been installed in several stations. Calibration procedures provided some improvement, but this will not suffice as range accuracy requirements continue toward the mm level.

The Consolidated Prediction Format (CPF) has now been fully implemented, with commensurate improvement in prediction quality. The new Consolidated Range laser range Data format (CRD), that accommodates higher range accuracy and extended one-way and two-way ranging to planetary distances is being implemented as the new ILRS standard. It is already in use at several stations; full transition for the network is scheduled for early 2010.

A Laser Workshop was held in Grasse, France in September 2007. The Sixteenth Workshop on Laser Ranging was held in Poznan, Poland in November 2008. Both workshops included a week-long format covering analysis, ranging systems hardware and software, and retroreflector arrays provided a venue for scientists, analysts, and practitioners to meet and discuss technique issues and new ideas. The proceedings for both are accessible through the ILRS website. We thank the organizers and sponsors of both meetings, the Space Research Centre of the Polish Academy of Sciences and the Observatoire de la Cote D'Azur, for their excellent arrangements and wonderful hospitality. The workshops were certainly highlights of this reporting period. The Seventeenth Workshop on Laser Ranging will be held in Concepcion, Chile in November 2010.

By the end of 2008, the ILRS community was assembling its data product for submission for the ITRF 2008. Eight analysis centers were preparing their solutions of time-dependent station positions for submission to the Combination Centers at the ASI and DGFI.

A number of new satellites were added to the ILRS roster during this period. TerraSAR-X, and Jason-2 (with the T2L2 timing experiment) are making fundamental contributions to Earth Science. Three new GNSS satellites were added during this period including GLONASS 115, GIOVE-B, and Compass- M1. Of particular note, both GLONASS 115 and Compass-M1 carried retroreflector arrays with uncoated cubes for improved array effective cross-section. The improvement in data yield was quite evident.

The ILRS continued its support the IAG's Global Geodetic Observing System (GGOS). The book, "Global Geodetic Observing System: Meeting the Requirements of a Global Society in a Changing World" with a number of contributions from the ILRS, has been published by Springer. To help support future space geodesy requirements, the ILRS has undertaken a simulation activity to help scope future network design.

I would like to thank all of our colleagues in the tracking network, at the Central Bureau, the analysis and data centers, those who undertook additional duties as working group chairs or members, for their continuous contribution to our Service. Special thanks of course to the agencies, institutions and foundations for their ongoing financial support of our activities.

Werner Gurtner
Chairman, ILRS Governing Board
Astronomical Institute
Bern, Switzerland
September 2009

SECTION 1

ABOUT ILRS

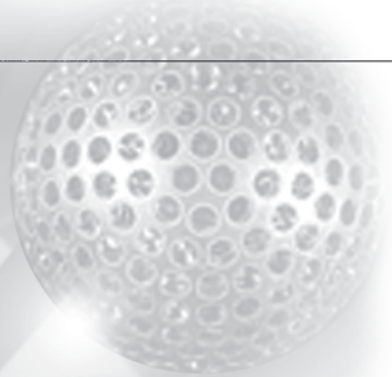

FRASER PANGLOSS



SECTION 1

ILRS ORGANIZATION

Michael Pearlman/CfA

The Mission of the ILRS

The International Laser Ranging Service (ILRS) organizes and coordinates Satellite Laser Ranging (SLR) and Lunar Laser Ranging (LLR) to support programs in geodetic, geophysical, and lunar research activities and provides the International Earth Rotation and Reference Frame Service (IERS) with products important to the maintenance of an accurate International Terrestrial Reference Frame (ITRF). This reference frame provides the stability through which systematic measurements of the Earth can be made over thousands of kilometers, decades of time, and evolution of measurement technology. The Service provides precision ephemerides to support active Earth sensing missions and is now preparing to support extraterrestrial missions with optical transponders. The ILRS is one of the technique services of the International Association of Geodesy (IAG).

The Role of the ILRS

The International Laser Ranging Service (ILRS):

- coordinates activities for the international network of SLR stations;
- develops the standards and specifications necessary for product consistency;
- develops the priorities and tracking strategies required to maximize network efficiency;
- collects, merges, analyzes, archives and distributes satellite and lunar laser ranging data to satisfy user needs;
- provides quality control and engineering diagnostics to the global network;
- works with new satellite missions in the design and building of retroreflector targets to maximize data quality and quantity;
- works with science programs to optimize scientific data yield; and
- encourages the application of new technologies to enhance the quality, quantity, and cost effectiveness of its data products;

ILRS Data Products

Official Submission to the IERS

- Weekly solutions for station coordinates and Earth Orientation Parameters (EOPs) for the derivation of scale (Gm) and time-varying Earth Center of Mass for the ITRF

Other User Products

- Static and time-varying coefficients of the Earth's gravity field
- Accurate satellite ephemerides for POD and validation of altimetry, relativity, and satellite dynamics
- Backup POD for other missions
- Lunar ephemeris for relativity studies and lunar libration for lunar interior studies

The Structure of the ILRS

The ILRS is composed of the following components, shown in Figures 1-1 and 1-2:

- Forty Satellite Ranging Stations that provide ranging data on an hourly basis and two Lunar Ranging Stations;
- Three Operations Centers that collect and verify the satellite data and provide the Stations with sustaining engineering, communications links, and other support;
- Two Global Data Centers that receive and archive data and supporting information from the Operations Centers and provide these data to the Analysis Centers; and receive and archive ILRS scientific data products from the Analysis Centers and provide them to the users;
- Two Combination Centers that prepare the ILRS weekly data product for the IERS; six SLR Analysis Centers that provide the input solutions to the Combination Centers for the data product process, eighteen Associate Analysis Centers that provide specialized SLR products to the users community and provide a second level of data quality assurance in the network; and four Lunar Analysis Centers that provide lunar data products;
- Five ILRS Working Groups that provide technical expertise and help formulate policy;
- ILRS Central Bureau that is responsible for the daily coordination and management of ILRS activities including communications and information transfer, monitoring and promoting compliance with ILRS network standards, monitoring network operations and quality assurance, maintaining documentation and databases, and organizing meetings and workshops;
- Governing Board that is responsible for general direction, defining official ILRS policy and products, determining satellite-tracking priorities, developing standards and procedures, and interacting with other services and organizations.

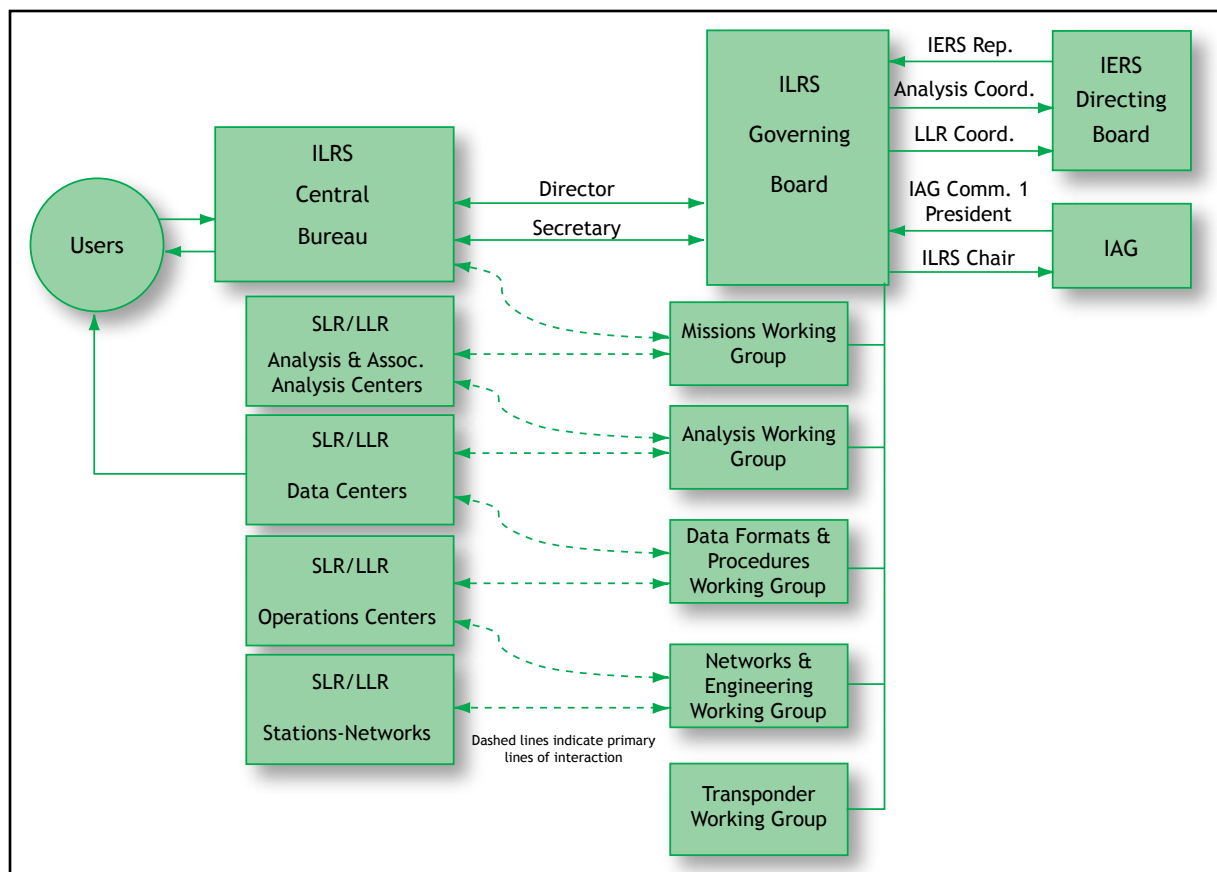

Figure 1-1. ILRS Organization

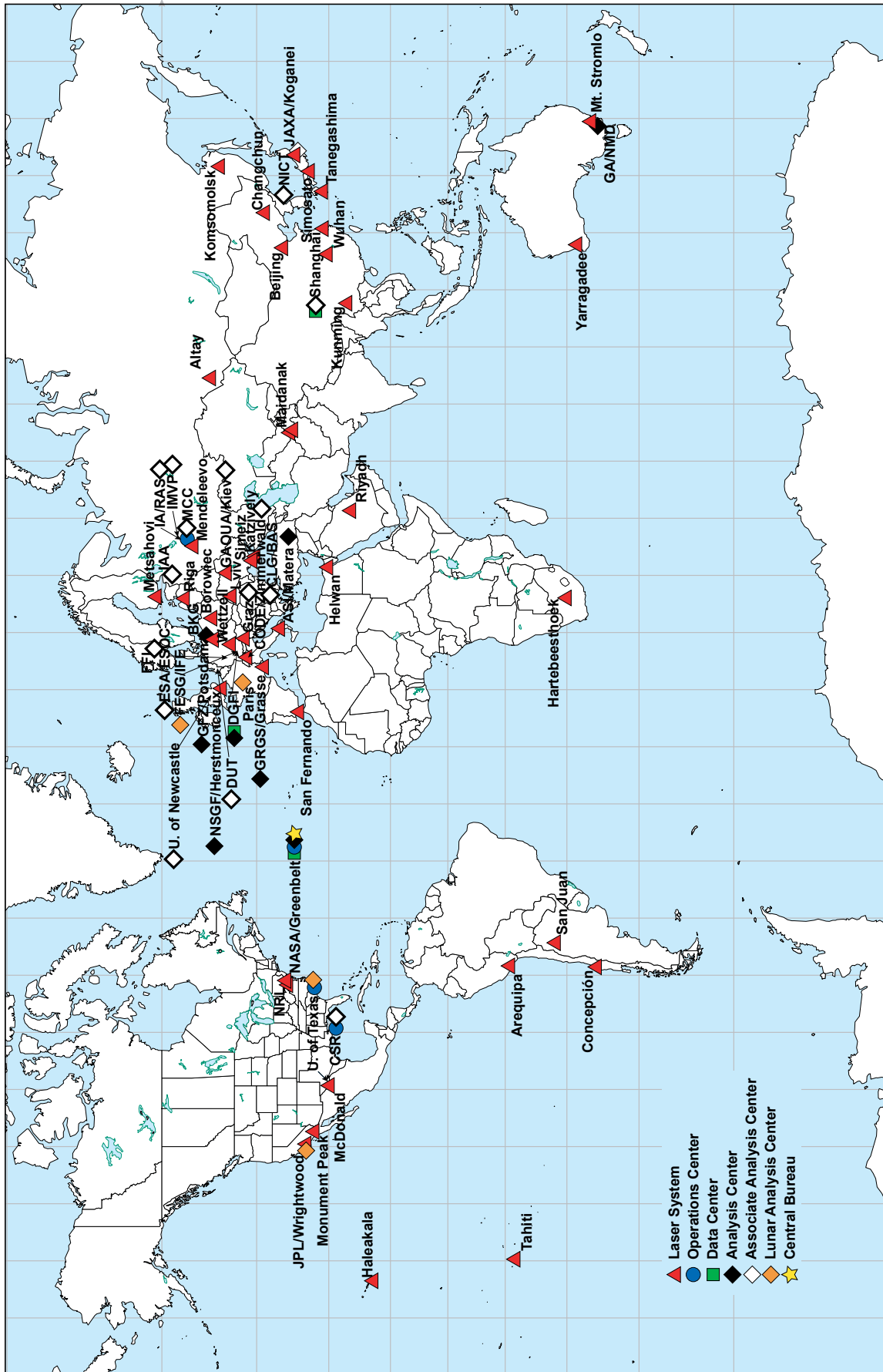

Figure 1-2. Components of the ILRS in 2007-2008.

ILRS Information and Outreach

The ILRS Central Bureau (staff shown in Figure 1-3) maintains a comprehensive Web site as the primary vehicle for the distribution of information within the ILRS community. The site, which can be accessed at: <http://ilrs.gsfc.nasa.gov> is also available at a mirrored site at the European Data Center (EDC) in Munich. The ILRS also provides service-wide bulletins on SLRmail and ILRS exploders and specialized bulletins through Working Group and Urgent Mail exploders.



*Figure 1-3. ILRS Central Bureau staff (left to right): Jan McGarry, Carey Noll, Erricos Pavlis, Frank Lemoine, Michael Pearlman, Mark Torrence, Peter Dunn, Julie Horvath, and Curtis Emerson.
Other members not present: David Carter, Bart Clarke, Mark Davis,
Bud Donovan, Randy Ricklefs, and Scott Wettzel.*

ILRS GOVERNING BOARD



Name: Graham Appleby
Position: At-Large Representative
Affiliation: Natural Environmental Research Center (NERC) Space Geodesy Facility (NSGF), UK

Name: Yang Fumin
Position: WPLTN Network Representative
Affiliation: Shanghai Astronomical Observatory (SAO), China



Name: Giuseppe Bianco
Position: EUROLAS Network Representative
Affiliation: Agenzia Spaciale Italiana (ASI), Italy

Name: Werner Gurtner
Position: Chairman and EUROLAS Network Representative
Affiliation: Astronomical Institute, University of Bern (AIUB), Switzerland



Name: David Carter
Position: NASA Network Representative
Affiliation: NASA Goddard Space Flight Center, USA

Name: Georg Kirchner
Position: At Large Representative
Affiliation: Austrian Academy of Sciences, Austria



Name: Zuheir Altamimi
Position: Ex-Officio, President of IAG Commission 1
Affiliation: Institut Géographique National, France

Name: Ramesh Govind
Position: WPLTN Network Representative
Affiliation: Geoscience Australia, Australia



ILRS Governing Board (continued)



Name: Vincencia Luceri
Position: Analysis Center Representative
Affiliation: Telespazio S.p.A./Centro di Geodesia Spaziale, Italy

Name: Erricos Pavlis
Position: Analysis Center Representative
Affiliation: Joint Center for Earth Systems Technology (JCET) and Goddard Space Flight Center (GSFC), USA



Name: Jan McGarry
Position: NASA Network Representative
Affiliation: NASA Goddard Space Flight Center, USA

Name: Michael Pearlman
Position: Ex-Officio, Director, ILRS Central Bureau
Affiliation: Harvard-Smithsonian Center for Astrophysics (CfA), USA



Name: Jürgen Müller
Position: Lunar Representative
Affiliation: U. of Hannover/Institut für Erdmessung (IFE), Germany

Name: Bob Schutz
Position: IERS Representative to ILRS
Affiliation: Center for Space Research (CSR), University of Texas, USA



Name: Carey Noll
Position: Ex-Officio, Secretary, ILRS Central Bureau
Affiliation: NASA Goddard Space Flight Center, USA

Name: Wolfgang Seemueller
Position: Data Center Representative
Affiliation: Deutsches Geodätisches Forschungsinstitut (DGFI), Germany



SECTION 2

ILRS TRACKING NETWORK

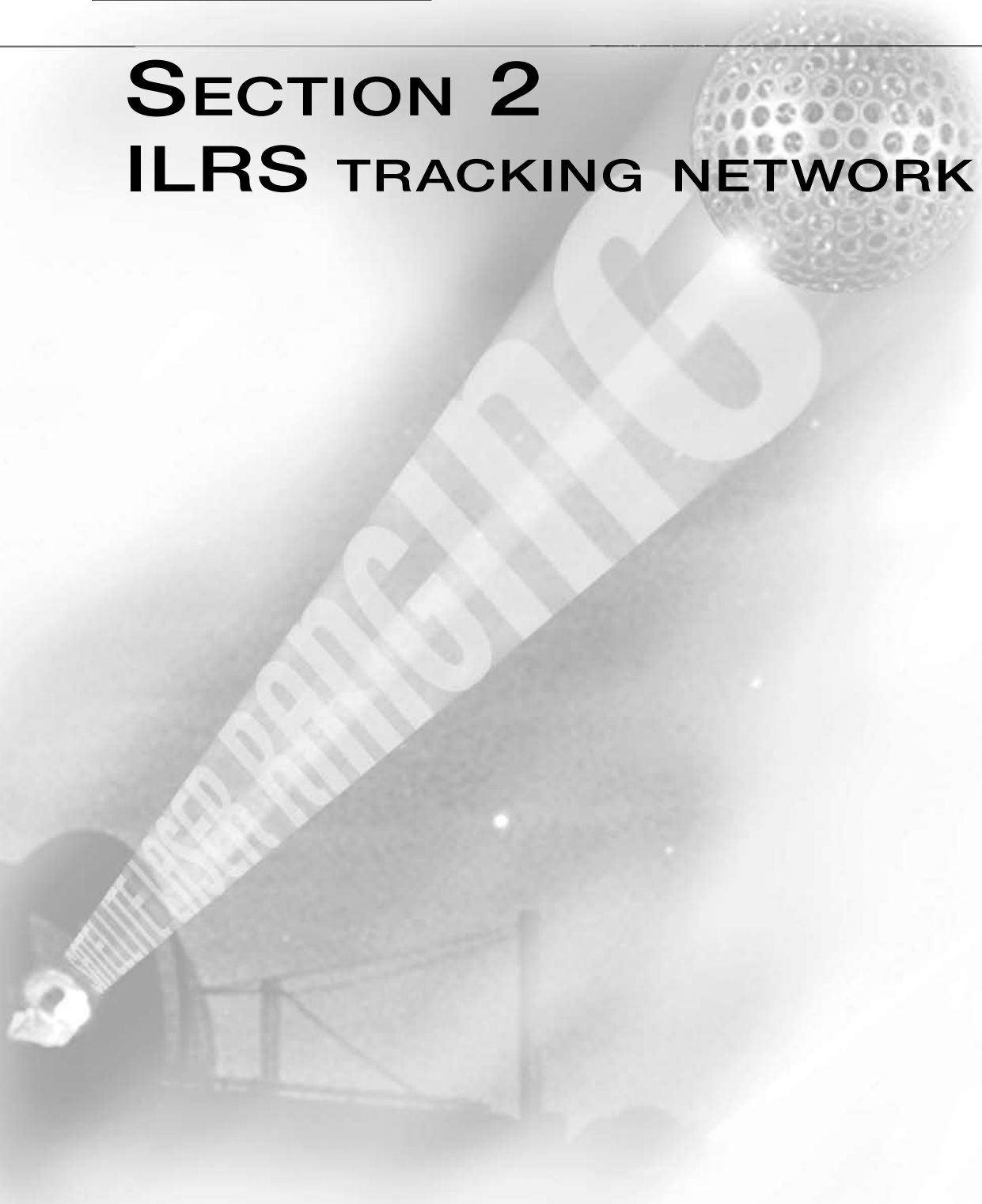

SECTION 2

SATELLITE LASER RANGING (SLR) NETWORK

Michael Pearlman/CfA

The present ILRS network, as shown in Figure 2-1, includes forty stations in 23 countries. Stations designated as operational have the minimum ILRS qualification for data quantity and quality. A dozen stations dominated the network with the Yarragadee, Mt Stromlo, and San Juan stations being the strongest performers. Since operations began about two years ago, the San Juan station performance has been dramatic; in 2008 station performance has risen to second only to Yarragadee. Congratulations to the San Juan team. There has also been noticeable improvement at Greenbelt, San Fernando, Concepción, Mount Haleakala, Arequipa and Katziwely. The improved orbital coverage over the Pacific region should have a very fundamental impact on our ILRS data products. Problems that have caused reduction of data at Monument Peak and Hartebeesthoek are being addressed and should be remedied shortly.

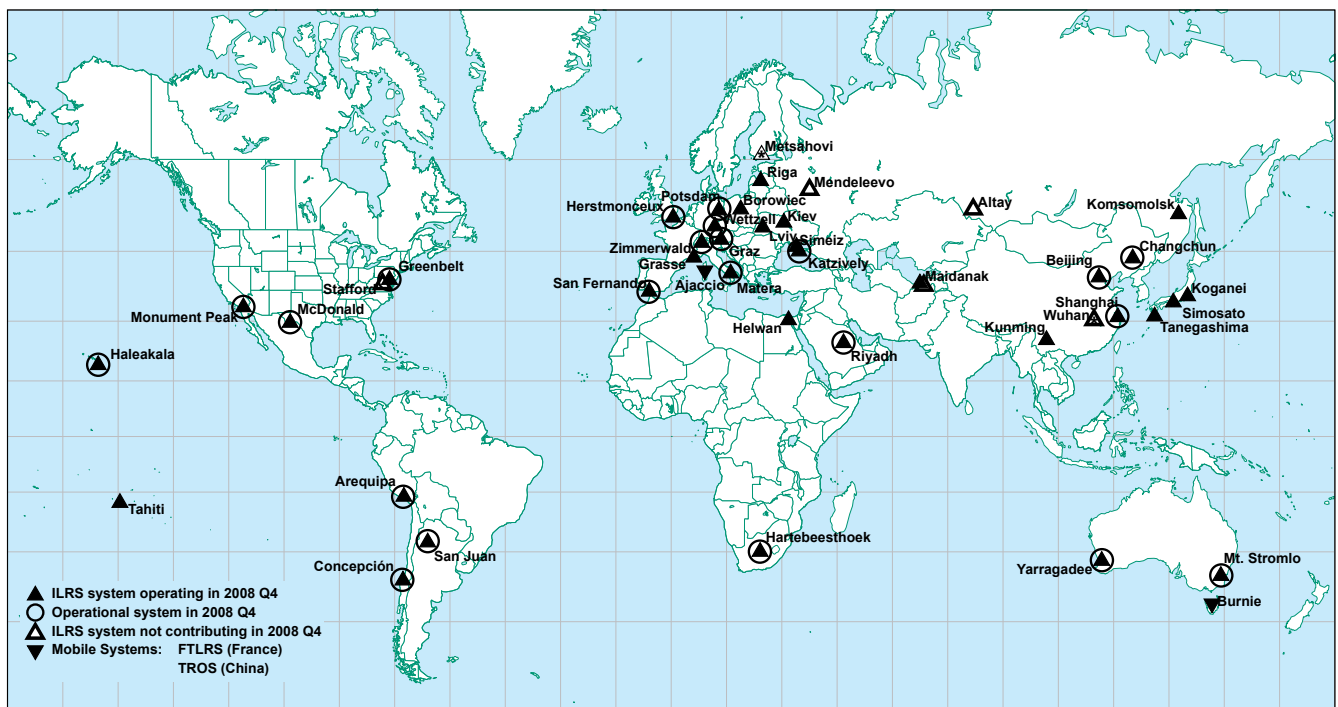

Figure 2-1. ILRS tracking network in 2007-2008.

A NASA/CNES/UPF team visited the Papeete site in late 2008 and formulated a report with a set of recommendation to improve site performance. The Arequipa stations and Mt Haleakala stations were both rededicated in early 2007 with TLR3 and -4 respectively; both are back in operation. A second shift was added to the Greenbelt station, substantially increasing data yield.

In addition to San Juan, the rest of the Chinese SLR network continues its outstanding support of the ILRS network. The Changchun station maintained its very strong performance; activities continue to help strengthen daylight ranging. Data yield continues to improve at the new Shanghai station. The Chinese Mobile TROS system had its first session at the Korea Astronomy and Space Science Institute (KASI), Daejeon, Korea from August to October 2008; the next session is scheduled for mid-April through early July, 2009.

The Riyadh station continues to do well; playing a vital role in the network as the only SLR station on the Arabian Peninsula.

A number of other stations have started or completed system upgrades during the last two years. The TIGO system in Concepción, Chile underwent substantial repairs in the 2005-6 time frame and is now performing very well, having reached full operational status in the network. Congratulations to the team.

System upgrades are nearly complete at the MEO station at Grasse; the station should be on the air in early 2009 with both SLR and LLR. The French Transportable Laser System (FTLRS) conducted campaigns in Ajaccio, France and in Burnie, Tasmania to support altimeter calibration and validation for Jason. While located at these sites, the system also supported general ILRS requirements.

The Graz system continues its impressive performance with 2 kHz operation, a technology that will most likely become more prevalent in the network as time goes on. A 2 kHz laser has been added to the Herstmonceux station; several other stations have this upgrade underway. Several stations have replaced their Stanford Counter with epoch timers and replaced their detectors with SPADs.

In 2007, the Zimmerwald station using its two-wavelength system collected the second largest number of passes in the network, second only to Yarragadee. Zimmerwald introduced a new 100 Hz Nd:YAG laser into their operation in the spring of 2008, and rapidly became again one of the major data producing stations in the network in 2008.

The GUTS facility in Tanegashima, Japan was brought back into operation after suffering severe storm damage, but data yield is still sparse.

We also expect that the Russian stations will again submit their data in early 2009. The CB is working with the sponsoring organizations to complete the required site log forms. In particular, the Altay station will begin participating in the ILRS in early 2009.

The Next Generation SLR (NGSLR) is now routinely collecting data at GSFC. Many of the subsystems including the Risley prism point-ahead are working and co-location with MOBLAS-7 will start at the beginning of 2009. There are still many things to clean up, but congratulations go to the NGSLR team; it has been a long hard road.

Lunar Laser Ranging (LLR) Network

Jürgen Müller/IfE

The 40 anniversary of the first manned landing on the Moon in 1969 is also the 40 anniversary of laser tracking the Moon. During three US Apollo missions (11, 14, and 15) and two un-manned Soviet missions (Luna 17 and Luna 21) retro-reflectors were deployed near the landing sites between 1969 and 1973 (see Figure 2-2). The lunar laser ranging (LLR) experiment has continuously provided range data for about 40 years, generating about 16000 normal points. The main benefit of this space geodetic technique is the determination of a host of parameters describing lunar ephemeris, lunar physics, the Moon's interior, various reference frames, Earth orientation parameters and the Earth-Moon dynamics. LLR has also become the strongest tool for testing Einstein's theory of general relativity in the solar system (e.g., tests of the equivalence principle, time-variable gravitational constant, metric parameters); no violations of general relativity have been found so far (e.g., Müller et al., 2007). Even further predictions of general relativity (secondary effects), which were

not fit for in the past, can be investigated, e.g., those parametrizing effects of modifications of Einstein's theory (Will, 1993). In addition, quantum physical predictions, assuming Lorentz violation, which will manifest itself as oscillatory perturbation of the lunar orbit (Battat et al., 2007) can be determined. However, the basis is more high quality data from a well-distributed global LLR network.

Despite steadily improving tracking technology, lunar ranging is extremely challenging. Because of the large lunar distance, energy loss in the atmosphere, the small reflector sizes on the Moon, and the limited telescope apertures, the laser link budget is extremely poor. Therefore, from all of the ILRS observatories (>30), there are only a few sites that are technically equipped to carry out Lunar Laser Ranging to the Moon (Figure 2-3). The McDonald Observatory in Texas, USA and Observatoire de la Côte d'Azur (OCA), France were the only currently operational LLR sites achieving a typical range precision of a few cm. The latter has been undergoing renovation since 2006, which left only one site operational over the past years. But in April 2009, the new OCA laser ranging system was inaugurated and it is planned to track the Moon again starting in summer 2009.

A new site with lunar capability has been built at the Apache Point Observatory, New Mexico, USA, equipped with a 3.5 m telescope. This station, called APOLLO, is designed for mm accuracy ranging. A few releases of data from APOLLO were added to the set of normal points used for the global LLR based parameter determination. The data look promising, but are still not provided on an operational basis.

The Australian station at Mt. Stromlo is expected to join this group in the future, and there are plans for establishing lunar capability at the South African site of Hartebeesthoek, and at Wettzell observatory, Germany, once there are new telescopes installed. Also other modern stations have demonstrated lunar capability, e.g., the Matera Laser Ranging Station, Italy in 2005, but all of them suffer from funding restrictions or technical problems when upgrading their systems. Hopefully, further sites may provide lunar data on a routine basis in the near future.

Current LLR data is collected, archived and distributed under the auspices of ILRS. All former and current LLR data is electronically accessible through the EDC in Munich, Germany and the CDDIS in Greenbelt, Maryland.

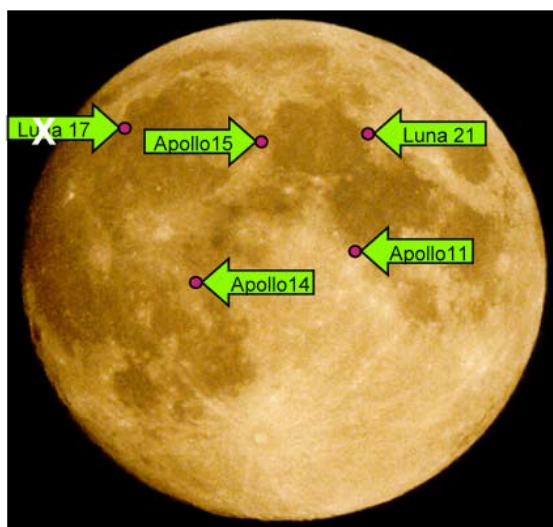

Figure 2-2. Retro-reflector sites on the Moon, Luna 17 has never been successfully tracked



Figure 2-3. ILRS sites with potential lunar capability demonstrated in the past or planned for the near future

References

- Battat, James B. R.; Chandler, John F. ; Stubbs, Christopher W.: Testing for Lorentz Violation: Constraints on Standard-Model-Extension Parameters via Lunar Laser Ranging. In: Physical Review Letters 99, No. 24, p. 241103, 2007
- Müller, J., Williams, J., Turyshchev, S., Shelus, P.: Potential Capabilities of Lunar Laser Ranging for Geodesy and Relativity. In: Dynamic Planet. P.Tregoning, C.Rizos (eds.), IAG Symposia 130, pp. 903-909, Springer, 2007, gr-qc/0509019.
- Will, C. M.: Theory and Experiment in Gravitational Physics, Cambridge University Press, England, 1993

Network Performance

Network Performance Report Cards are issued quarterly by the ILRS Central Bureau. These reports tabulate the previous 12 months of data quality, quantity, and operational compliance by station and can be found along with established guidelines for station performance on the ILRS Web site at: http://ilrs.gsfc.nasa.gov/stations/site_info/global_report_cards/index.html. The ILRS Central Bureau uses these report cards to maintain lists of the best performing stations which are tabulated at: http://ilrs.gsfc.nasa.gov/stations/station_classification.html.

As shown in Figures 2-4 through 2-7, network data yield dropped in 2004 due mainly to reductions in NASA network support and the Mt Stromlo outage, but data yield is recovering as these stations have come back into operation and as the rest of the network has become more proficient. Most notable is the pickup in LAGEOS and high satellites passes.

The network is still experiencing a wide dichotomy in performance. As can be seen in Figures 2-5 and -6, station data yield performance falls into three categories. About a quarter of the stations are very prolific, far exceeding the ILRS criteria for an operational stations. Another quarter of the stations are performing satisfactorily with some caveats on LAGEOS tracking. These two categories of stations are having a major impact on the development of reference frame and POD. Some of the stations on the lower half are recovering from engineering activities and will hopefully experience improved operations in 2009. All of the stations are meeting the 2 cm normal point RMS threshold, with about 75% operating below the cm level (see Figure 2-7).

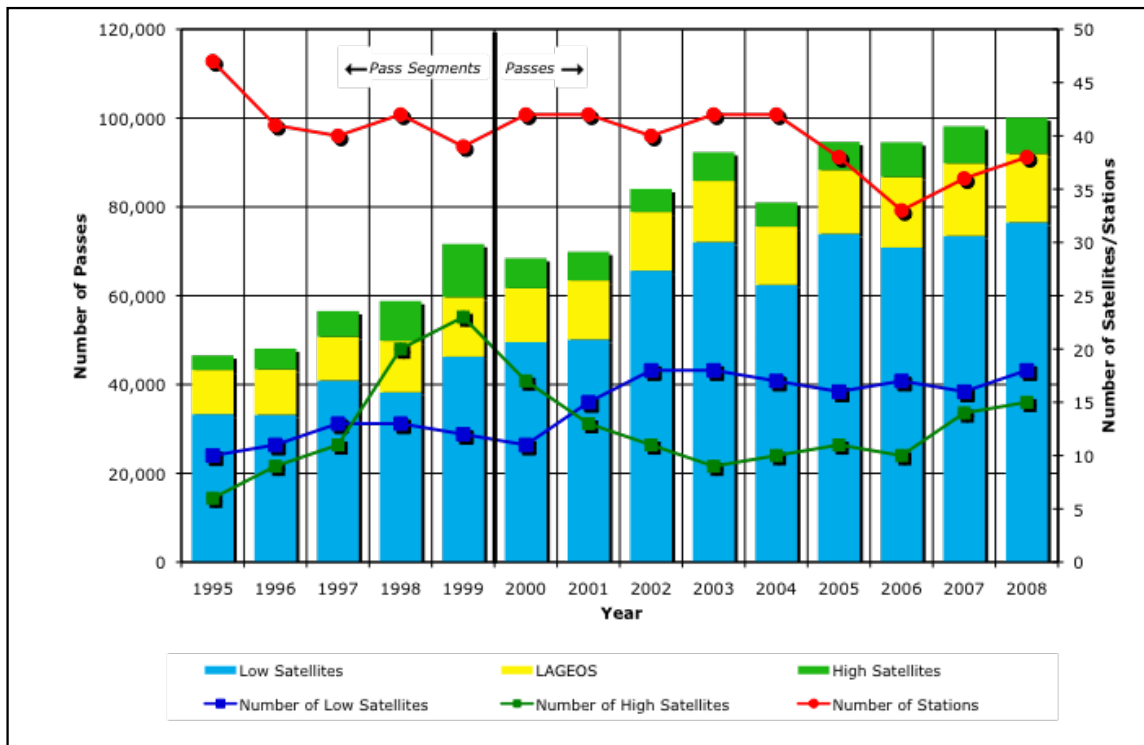

Figure 2-4. After the reductions in 2004, network data yield increased with the reopening of stations, improved network proficiency, and additional satellites.

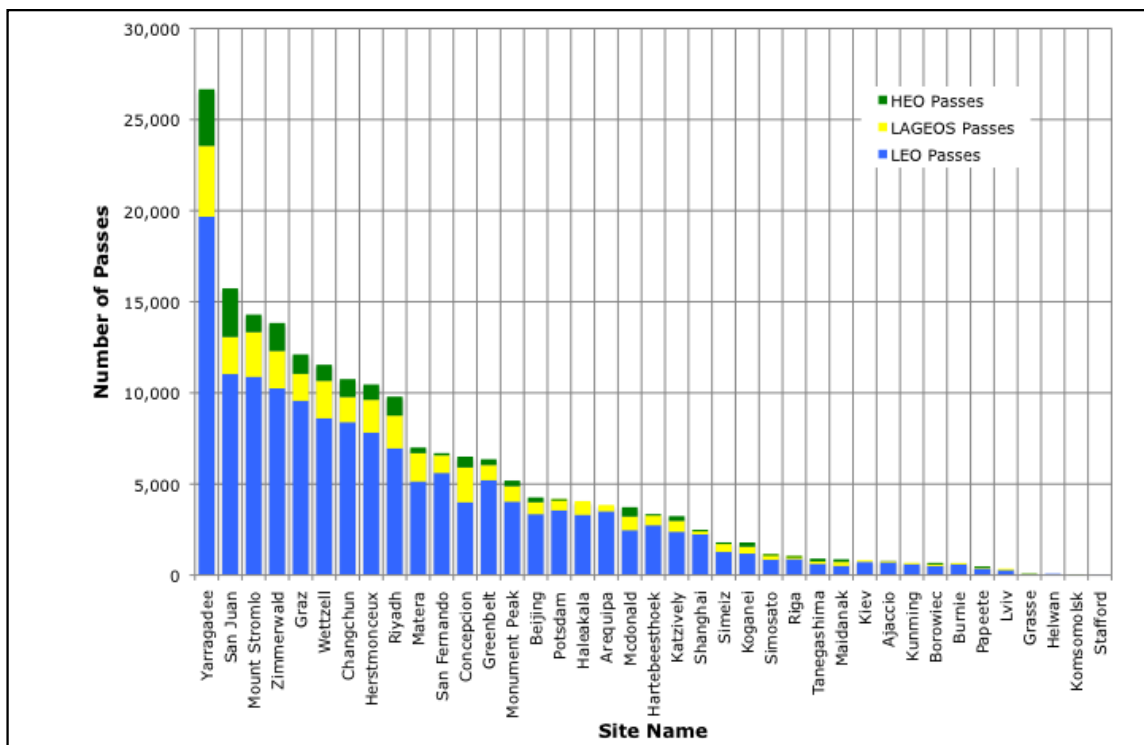

Figure 2-5. Number of passes tracked from January 2007 through December 2008.

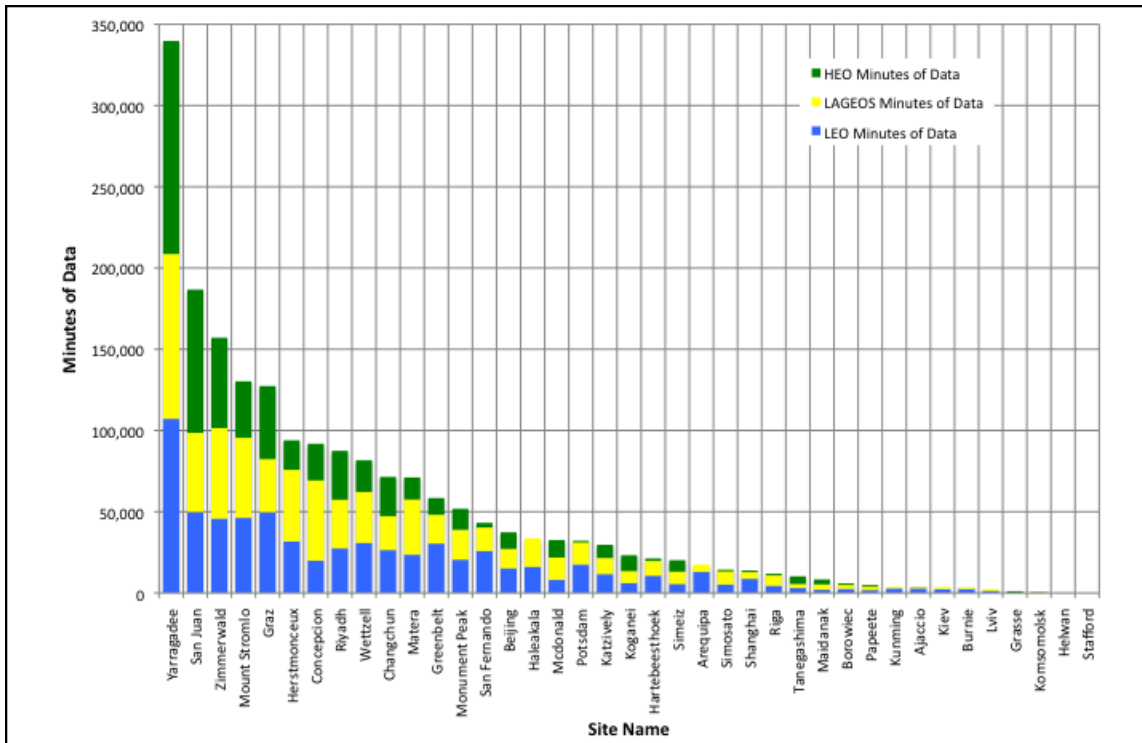

Figure 2-6. Number of minutes of data from January 2007 through December 2008.

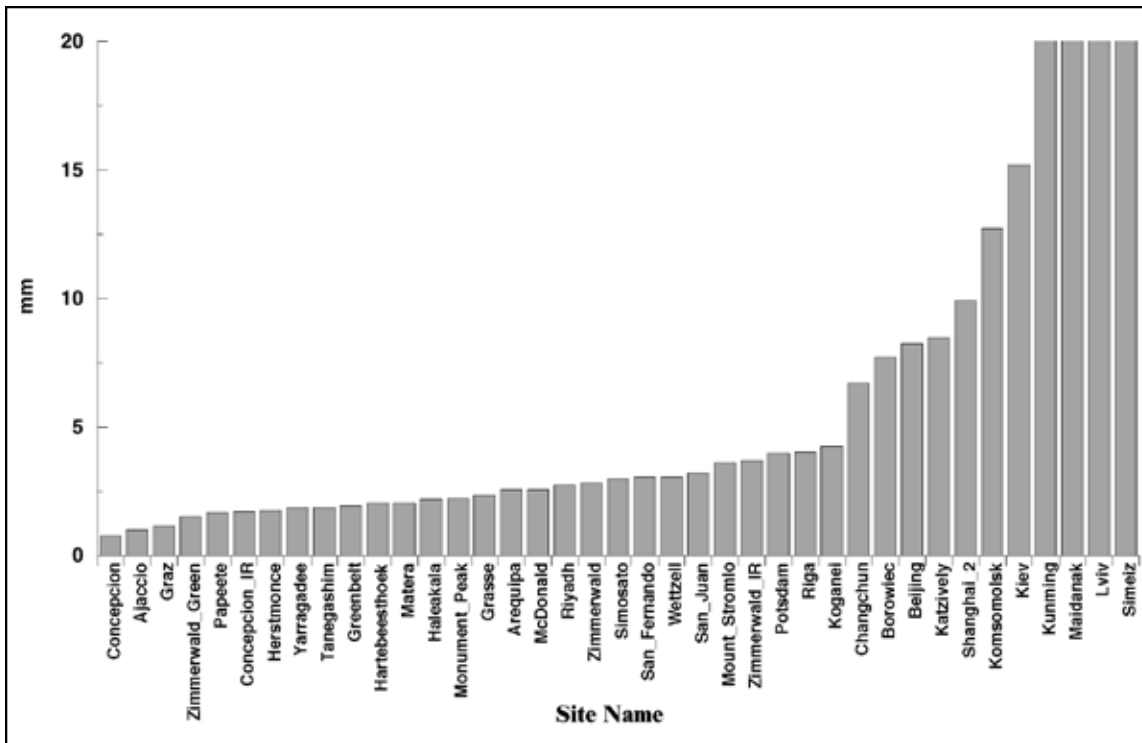

Figure 2-7. Average normal point precision in mm for data from January 2007 through December 2008 as calculated by Hitotsubatshi University, Japan.

Site Surveys and Co-Location Sites

Zuheir Altamimi/IGN and Michael Pearlman/CfA

The Terrestrial Reference Frame is the means by which we connect measurements over space, time and evolving technologies. Space may be ten thousand kilometers. Time will be decades and probably generations. Evolving technologies are the changes in the ground systems and the satellites that will happen as measurement capabilities improve. If we are going to see change in the Earth and its environment, we need the long-term stability of the reference frame.

Satellite Laser Ranging (SLR) is one of the fundamental geodetic techniques (along with GNSS, VLBI, and DORIS) that define and maintain the Terrestrial Reference System. Each technique is fundamentally different; each has its own unique strengths and its own systematic errors. We can exploit the strengths and mitigate the systematic errors through the co-location of space techniques (SLR, GNSS, VLBI, and DORIS) at common sites. This is an essential part in our achievement of the high-accuracy Terrestrial Reference Frame.

Site surveys between co-located instruments are a basic, but often unappreciated aspect in the development of the reference frame. The value of sub-centimeter measurements across intercontinental distances can be lost through missing or inaccurate local ties, inconsistencies in ground survey techniques, poor survey control network geometry and monumentation, improper analysis of survey data, and lack of proper documentation.

The very existence of the ITRF relies on the availability and quality of local ties in co-location sites as well as the number and distribution of these sites over the globe. A co-location site is defined by the fact that two or more space geodesy instruments are occupying simultaneous (or subsequently very close) locations, which are very precisely surveyed in three dimensions using classical surveys or/and the GNSS technique. Classical surveys are usually direction angles, distances, and spirit leveling measurements between instrument reference points or geodetic markers. Adjustments of local surveys are performed by national geodetic agencies operating space geodesy instruments to provide differential coordinates (local ties) connecting the co-located instruments.

Current Status of the Co-location Sites

The VLBI and SLR networks each include less than fifty sites. The DORIS network is more homogeneous and includes 56 sites. The IGS GNSS network contains more than 350 permanent sites. In the worldwide currently operating Space Geodesy Network, 59 sites host two observing techniques (SLR, GNSS, VLBI, and/or DORIS); only 17 sites have three, and only two sites have four, as illustrated by Figure 2-8. The figure shows also seven sites where local ties are missing: (four VLBI-GNSS, one SLR-VLBI, one SLR-GNSS and one DORIS-GNSS).

The status of site co-locations with SLR is show in Table 2-1 and Figure 2-8. There are currently only three SLR sites operating with SLR, GNSS, VLBI, and DORIS, and ten SLR sites operating with GNSS and VLBI. Seven are co-located with DORIS. All of the SLR sites in the ILRS operational network are co-located with GNSS; six of the other participating SLR stations do not have GNSS. The distribution of these co-located sites is not well placed and in some cases operations of one or more of the techniques is marginal. Local surveys are also an issue at nine of the SLR co-located sites.

Co-location of techniques and measurement and monitoring of local inter-technique vectors to the mm level must continue to be a high priority with the SLR network.

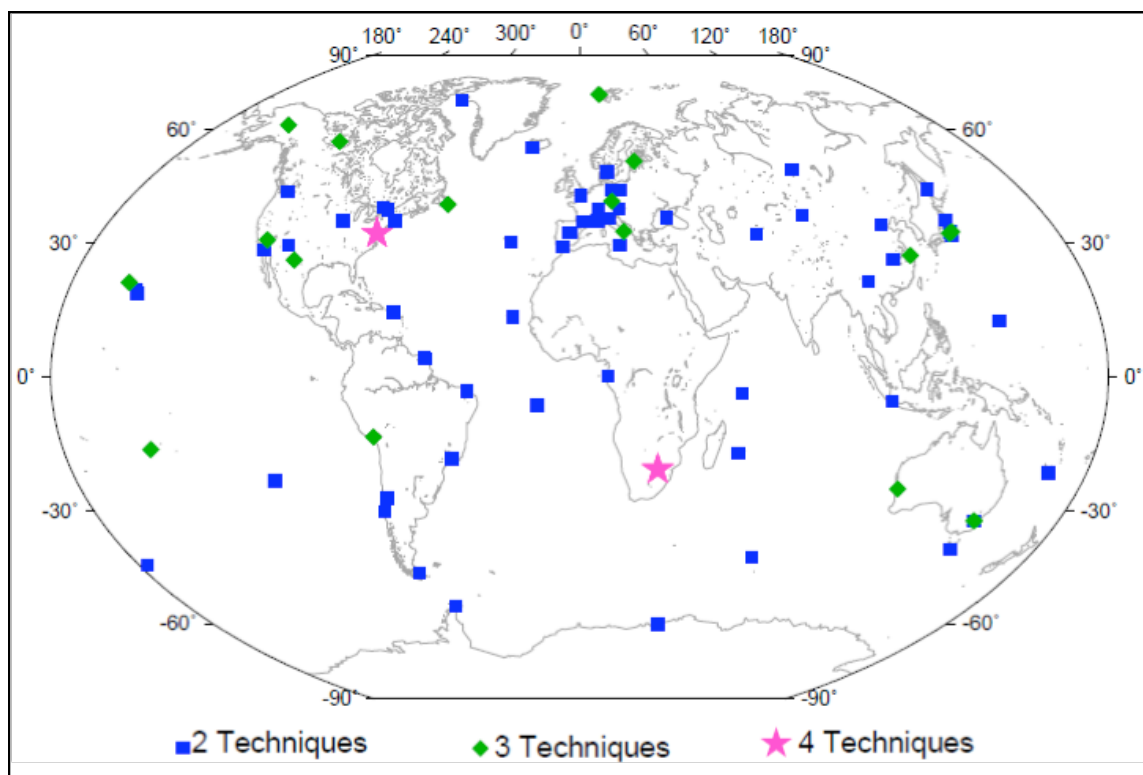

Figure 2-8. Current status of SLR, VLBI, DORIS, and GNSS co-locations.

New Surveys

During this period, The Institut Géographique National (IGN), France conducted complete surveys of the following two co-location sites:

- Tahiti, comprising three techniques: SLR, GNSS and DORIS
- Herstmonceux, comprising two techniques: SLR and GNSS

The adjustment of these three surveys is accomplished, including final report and SINEX files, which are available at the ITRF web site <http://itrf.ensg.ign.fr/>.

Table 2.1. Space Techniques Co-Located with SLR (2007-2008)

Site Name	Country	GNSS	VLBI	DORIS	Gravimeter
Ajaccio ¹	France	X			
Arequipa	Peru	X		X	
Beijing	China	X			X
Borowiec	Poland	X			X
Burnie ¹	Tasmania				
Changchun ²	China	X			
Concepción	Chile	X	X		X

Grasse	France	X			X
Graz	Austria	X			X
Greenbelt, MD	USA	X	X	X	
Haleakala, HI	USA	X			
Hartebeesthoek	South Africa	X	X	X	
Helwan ²	Egypt	X ³			
Herstmonceux	UK	X			X
Katzively	Ukraine				
Kiev	Ukraine	X			
Koganei	Japan	X	X		
Komsomolsk	Russia				
Kunming ²	China	X			X
Lviv ²	Ukraine	X			
Maidanak	Russia				
Matera	Italy	X	X		X
McDonald, TX	USA	X	X		
Mendeleev	Russia	X			
Metsahovi	Finland	X	X	X	X
Monument Peak, CA	USA	X		X	
Mount Stromlo	Australia	X		X	X
Potsdam	Germany	X			X
Riga	Latvia	X			X
Riyadh ²	Saudi Arabia	X			
San Fernando	Spain	X			
San Juan	Chile				
Shanghai	China	X	X		
Simeiz ²	Ukraine	X	X		
Simosato	Japan	X ³			
Stafford, VA	USA				
Tahiti	F. Polynesia	X		X	
Tanegashima ²	Japan	X			
Wetzell	Germany	X	X		X
Wuhan	China	X		X	X
Yarragadee	Australia	X		X	
Zimmerwald	Switzerland	X			X
Totals:	40	35	10	9	15

Notes: ¹ indicates mobile occupation in 2007-2008

² indicates missing tie

³ indicates non-IGS site (Simosato pending approval)

SECTION 3

MISSIONS AND CAMPAIGNS



SECTION 3

MISSIONS AND CAMPAIGNS

Michael Pearlman/CfA, Graham Appleby/NSGF, Scott Wetzell/HTSI

Current Missions

During 2007-2008, the ILRS supported 35 artificial satellite missions including passive geodetic (geodynamics) satellites, Earth remote sensing satellites, navigation satellites, and engineering missions. Missions were added to the ILRS tracking roster as new satellites were launched and as new requirements were adopted (see Figure 3-1). Seven missions were added to the roster during that period (see Table 3-1). The stations with lunar capability also tracked the lunar reflectors.

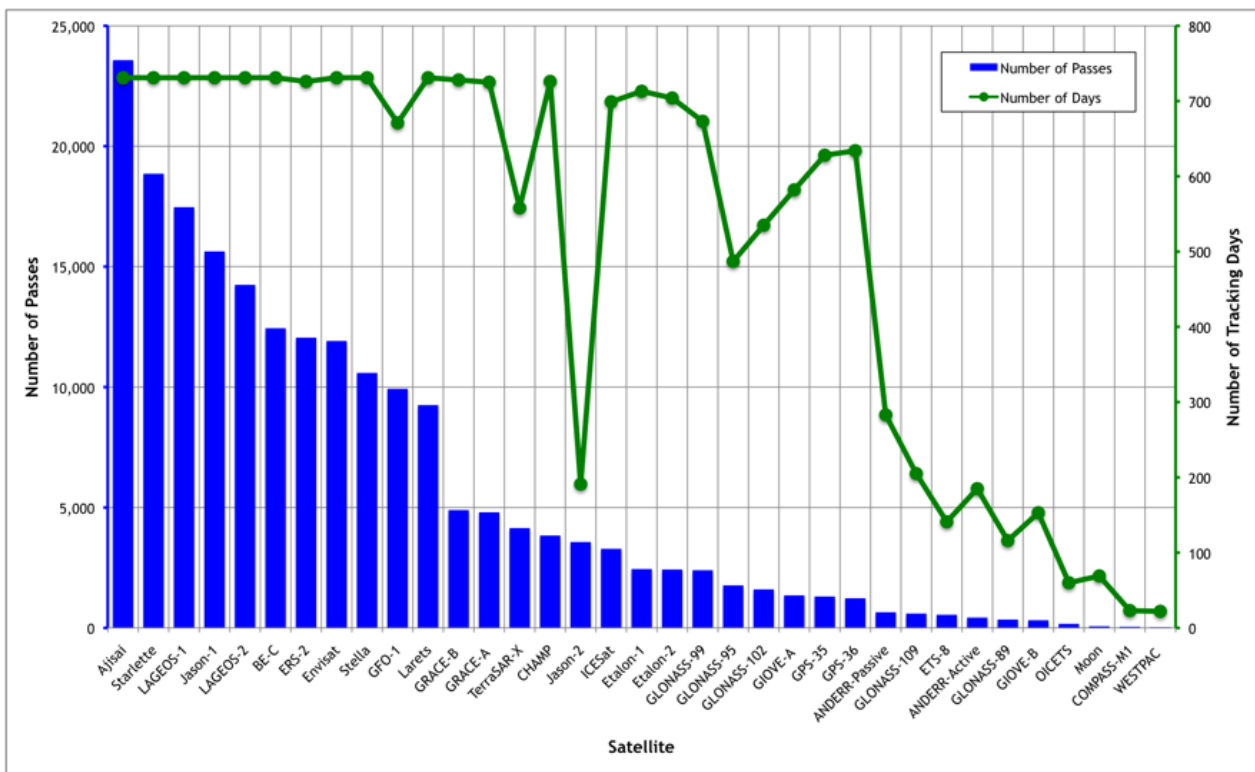

Figure 3-1. SLR tracking totals for 2007-2008.

The network continued to support the GLONASS constellation; GLONASS-102 replaced GLONASS-89 in May 2007. GLONASS-109 replaced GLONASS-95 in March 2008.

In March 2007, tracking began on ETS-8, the first ILRS target in a geostationary orbit. This is the first target above LAGEOS (except for the moon) that had uncoated cubecorners, which worked quite well. Several stations in the Pacific area have been able to range routinely.

The ANDE-RR satellites reentered in late 2007 and early 2008. The network was successful tracking these satellites down to 300 km and in some cases even below, a good indication of future success with GOCE. The GFO-1 mission ceased operating in November 2008. The radio systems aboard had failed at the beginning of the mission and SLR was the only means of POD for the altimeter.

Table 3-1. New Missions in 2007-2008

Mission	Date of First Pass	Sponsor	Application	ILRS Mission Support Requirement
ETS-8	March 2007	JAXA (Japan)	Technology Development	POD
TerraSAR-X	June 2007	Infoterra, DLR, GFZ (Germany)	X-band SAR	POD
GLONASS-102	July 2007	Russian Space Agency	Navigation	POD
GIOVE-B	April 2008	ESA (Europe)	Navigation	POD
GLONASS-109	May 2008	Russian Space Agency	Navigation	POD
Jason-2	June 2008	CNES/EUMETSAT / NASA/NOAA	Ocean Dynamics, Climate	POD, instrument validation
Compass-M1	December 2008	Chinese Defense Ministry, Shanghai Astronomical Obs.	Navigation	POD

Engineering Test Satellite 8 (ETS-8)

ETS-8, shown in Figure 3-2, was launched into a geostationary orbit to support development, experimentation and confirmation of large satellite bus technology, large-scale deployable antenna technology, mobile satellite communications system technology, mobile satellite digital multimedia broadcasting system technology and basic positioning technology using high-accuracy time standard devices. ETS-8, the largest geosynchronous satellite ever placed in orbit, was launched on December 16, 2006. JAXA plans to conduct a time synchronization experiment for future satellite positioning technology, including time management using an atomic clock onboard the satellite. SLR is providing POD for the mission. Of great interest initially was the use of uncoated retroreflectors (array shown in Figure 3-3) designed specifically to compensate for the velocity aberration.

More information can be found at the JAXA Web site: http://www.jaxa.jp/projects/sat/ets8/index_e.html.



Figure 3-2. ETS-8 satellite (courtesy of JAXA)

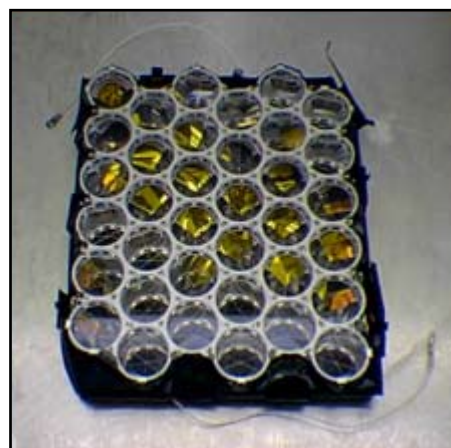

Figure 3-3. ETS-8 LRA (courtesy of HTSI)

TerraSAR-X

TerraSAR-X (Figure 3-4) is a mission with an active matrix, X-band Synthetic Aperture Radar (SAR), capable of mapping ground topography with a resolution of one meter for terrestrial research and applications. The SAR operates in all weather conditions during the daytime and at night. The satellite also has the experimental Tracking, Occultation and Ranging (TOR) package provided by GFZ and CSR, which consists of a two-frequency CHAMP type GPS receiver and a CHAMP Laser Retro-Reflector (LRR, Figure 3-5)). Data products include ortho-images, mosaics, coherence change detection, and topographical and thematic maps.

The satellite is the first to be built in a public/private partnership in Germany with Infoterra, DLR, GFZ and CSR in the U.S. The mission is also intended to establish a commercial Earth-Observation-market to develop a sustainable service business based on TerraSAR-X derived information products. Satellite laser ranging data provides precise orbit determination and validation and is complementary to the onboard TOR GPS.

More information is available from the GFZ Web site: [http://www.gfz-potsdam.de/portal/-?\\$part=CmsPart&\\$event=display&docId=1495914&cP=sec12.content.detail](http://www.gfz-potsdam.de/portal/-?$part=CmsPart&$event=display&docId=1495914&cP=sec12.content.detail).

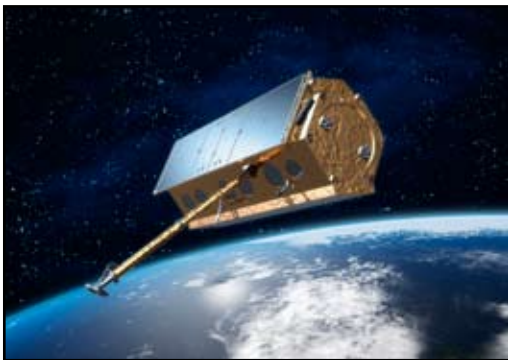

Figure 3-4. TerraSAR-X (courtesy of DLR).

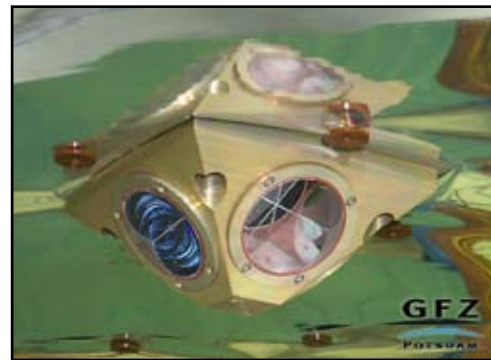

Figure 3-5. TerraSAR-X LRA (courtesy of GFZ)

GLONASS

The Global Navigation Satellite System (GLObal'naya Navigatsionnaya Sputnikovaya Sistema, GLONASS), is based on a constellation of active GNSS satellites, sponsored by the Russian Federation Ministry of Defense. The satellites continuously transmit coded signals in two frequency bands, which can be received by users anywhere on the Earth's surface to identify their position and velocity in real time. The primary application of GLONASS is positioning and time transfer. The satellites (shown in Figure 3-6) are in GNSS orbits at approximately 19,000 km.

The system is a counterpart to the United States Global Positioning System (GPS) and both systems share the same principles in the data transmission and positioning methods. On October 12, 1982, the first GLONASS satellites were placed into orbit, and the experimental work with GLONASS began. Since that time, the system was tested, and different aspects were improved, including the satellites themselves.



Figure 3-6. GLONASS satellite (courtesy JSC Information Satellite Systems–Reshetnev Company)

The Etalon-1 satellite was launched with GLONASS-40 and -41 and Etalon-2 was launched with GLONASS-42 and -43.

The GLONASS space segment is designed to consist of 24 satellites located on three orbital planes. Each satellite is identified by its slot number, which defines the orbital plane (1-8, 9-16, 17-24) and the location within the plane. The three orbital planes are separated 120 degrees. The eight satellites are separated by 45 degrees within three orbital planes. The current constellation consists of 18 or 19 operational satellites, with plane 3 fully occupied and plane 1 currently half-full. Additional satellites are currently being launched at a rate of six per year as required both to gradually fully-populate the constellation and as replacements for existing satellites. For more information see: <http://www.glonass-ianc.rsa.ru/pls/html/bf?p=202:20:16262908603374223037::NO>.

GIOVE-B

The Galileo constellation, a GNSS satellite radio navigation system initiative by the European Union and the European Space Agency, will consist of thirty satellites and ground stations providing position information to users in many sectors (transportation, social services, justice system, custom services, public works, search and rescue, etc.). Two experimental spacecraft, GIOVE-A and -B (formerly known as GSTB-V2/A and GSTB-V2/B), are in orbit and being tracked by the ILRS as a part of the Galileo System Test Bed to (1) secure the Galileo frequency allocations by providing a signal in space, (2) develop procedures for on-board clock characterization, (3) better understand the radiation environment, and (4) conduct related experiments.

GIOVE-A and GIOVE-B (shown in Figure 3-7) have different retroreflector arrays; both have flat arrays with solid back-coated cubes. The array for GIOVE-A (GSTB-V2/A) was built by Surrey Satellite Technology Ltd in the UK and has 76 cubes; the array for GIOVE-B (GSTB-V2/B) has been manufactured by Galileo Industries and has 67 cubes (see Figure 3-8). The signal link for both satellites is comparable to that of the GPS satellites. Arrays on the future Galileo satellites will have uncoated cubes that satisfy the ILRS standard for GNSS satellites.

For more information on the GIOVE aspects of the Galileo mission, refer to the ESA Web site <http://www.giove.esa.int/>.

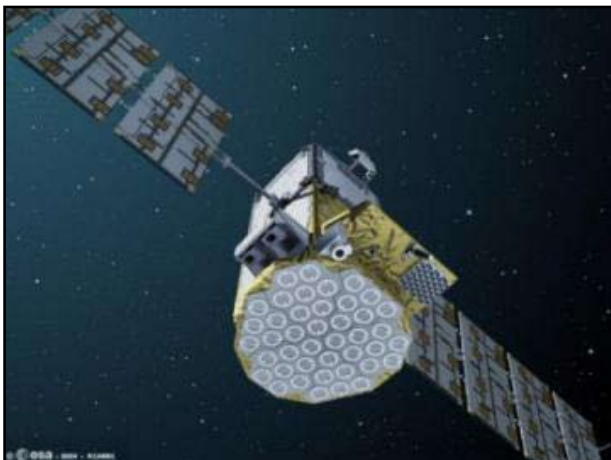

Figure 3-7. GIOVE-B satellite (courtesy of ESA)

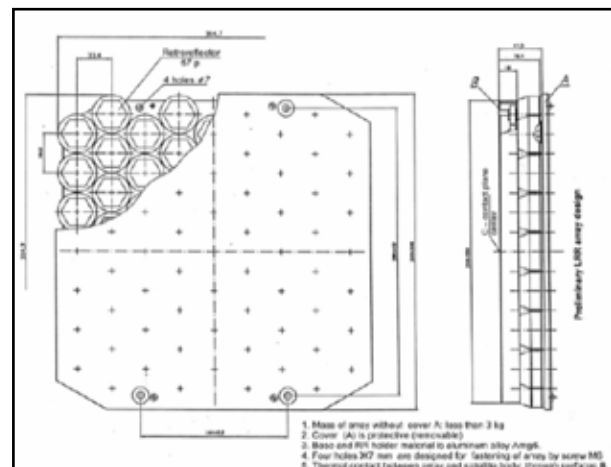

Figure 3-8. GIOVE-B array (courtesy of ESA)

Jason-2

Jason-2 (Figure 3-9), also known as the Ocean Surface Topography Mission (OSTM), continues the oceanography program begun by the earlier TOPEX/Poseidon and Jason-1 missions. Data products from Jason-2 are being used to monitor global ocean circulation, study the tie between the oceans and atmosphere, improve global climate predictions, and monitor events such as El Nino conditions and ocean eddies. The CNES, Eumetsat, NASA, and NOAA cooperative mission has nearly the same payload as Jason-1, including the next generation Poseidon altimeter, with a measurement accuracy of about 1 cm.

The Time Transfer by Laser Link (T2L2) payload (see <http://www-g.ocea.eu/heberges/t2l2/home.htm>), is also part of the Jason-2 satellite. T2L2 is now taking data for precise characterization of the ultra-stable oscillator used by the DORIS positioning system. Relying on this clock, T2L2 may also be able to perform some orbit improvements on Jason-2 using one-way laser ranging. Jason-2, at its high altitude and with its very long integration times, in common view mode, provides an excellent opportunity for time transfer over intercontinental links.

Precision orbit determination is a fundamental requirement for achieving the goal of Jason-2. Jason-2 also has GPS receivers, DORIS, and SLR for POD. The SLR data provides the crucial centering of the orbit relative to the Earth's center of mass and the absolute calibration of the radial orbit error. The array on Jason-2 is shown in Figure 3-10.

More information about the Jason-2 mission is available at the CNES Web site <http://www.cnes.fr/web/CNES-en/1441-jason.php>.



Figure 3-9. Jason-2 satellite
(courtesy of CNES)

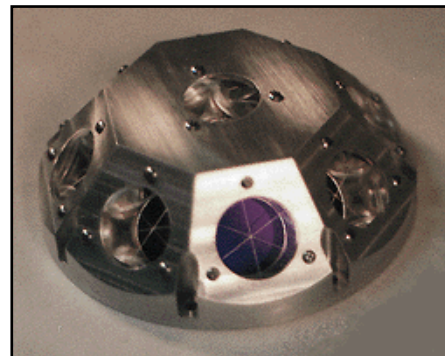

Figure 3-10. Jason-2 Array (courtesy of HTSI)

Compass-M1

The Compass Navigation Satellite Experimental System is a satellite constellation developed by the Chinese Defense Ministry; a diagram of Compass-M1 is shown in Figure 3-11. The system, also known as BeiDou, is the first space-based regional navigation and positioning network developed by China. Compass will provide all weather, two-dimensional positioning data for both military and civilian users. The system has both navigation and communication capabilities and spans most areas of the East Asia region. The satellite network consists of four BeiDou 1 satellites launched in 2000, 2003, and 2007 in geostationary orbit; a fifth satellite, Compass-M1, was launched in MEO in April 2007 with the first retroreflector array with uncoated cornercubes in GNSS orbit (see Figure 3-12).

For more information on Compass-M1 see: http://www.oca.eu/gemini/ecoles_colloq/colloques/ilrs2007PresentationsPdf/10_Session.pdf/10.1_Fumin_LRA_Compass.pdf.

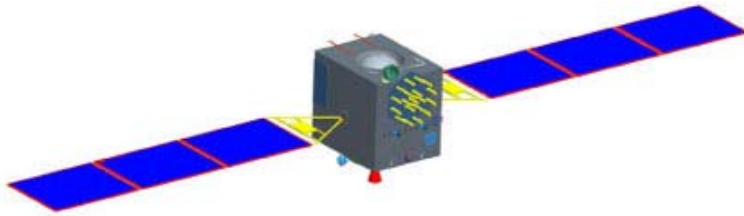

Figure 3-11. Compass-M1 satellite (courtesy of Shanghai Astronomical Observatory)



Figure 3-12. Compass-M1 Array (courtesy of Chinese Academy of Sciences)

Future Missions

A number of new missions, shown in Table 3-2, requiring SLR support for POD and instrument calibration and validation, are scheduled for launch over the next year.

Table 3-2. Upcoming Missions in 2009-2010.

Mission	Launch	Altitude (km)	Sponsor	Application	ILRS Mission Support Requirement
SOHLA-1	January 2009	666	JAXA (Japan)	Technology Development	POD
GOCE	March 2009	295	ESA (Europe)	Gravity field and Ocean circulation	POD and instrument calibration
ANDE	June 2009	350	NRL (US)	Atmospheric Modeling	POD
BLITS	June 2009	832	IPIE (Russia)	Test of retroreflector technology	Retroreflector in Space
LRO	June 2009	Lunar orbit	NASA	Lunar studies	POD in lunar orbit
PROBA-2	Second Quarter 2009	700 - 800	ESA (Europe)	Technology Development, solar studies	POD
QZS-1	Mid-2009	32,000 – 40,000	JAXA (Japan)	Navigation, position, timing	POD
STSAT-1	Mid-2009	390 - 1500	KIAST (Korea)	Technology development and Earth brightness	POD
TanDEM-X	Mid-2009	514	DLR, GFZ, EADS-Astrium, Infoterra	Digital elevation model	POD

Requests for new mission support by the ILRS should be submitted via the online request form on the ILRS Web site at http://ilrs.gsfc.nasa.gov/satellite_missions/mission_support.html. Requests are reviewed by the ILRS Missions Working Group for suitability and then vetted by the ILRS Governing Board. Mission sponsors must supply precise details of the on-board characteristics of the retroreflector arrays as part of their Mission Support Request at the above link.

GOCE

The GOCE (Gravity field and steady-state Ocean Circulation Explorer) is an ESA mission dedicated to measuring the Earth's gravity field and modeling the geoid with extremely high accuracy and spatial resolution. It is the first Earth Explorer Core mission to be developed as part of ESA's Living Planet Program. The satellite (shown in Figure 3-13) consists of a single rigid octagonal spacecraft, approximately 5 m long and 1 m in diameter with fixed solar wings and no moving parts. The main objectives of the mission are to: (1) determine the gravity-field anomalies with an accuracy of 1 mGal (where 1 mGal = 10^{-5} m/s²), (2) determine the geoid with an accuracy of 1-2 cm, and (3) achieve the above at a spatial resolution better than 100 km. Mission instrumentation includes: a gravity radiometer, a 12-channel GPS receiver, and a laser retroreflector array (Figure 3-14).

For additional information see: <http://www.esa.int/esaLP/LPgoce.html>.



Figure 3-13. GOCE satellite (courtesy of ESA)

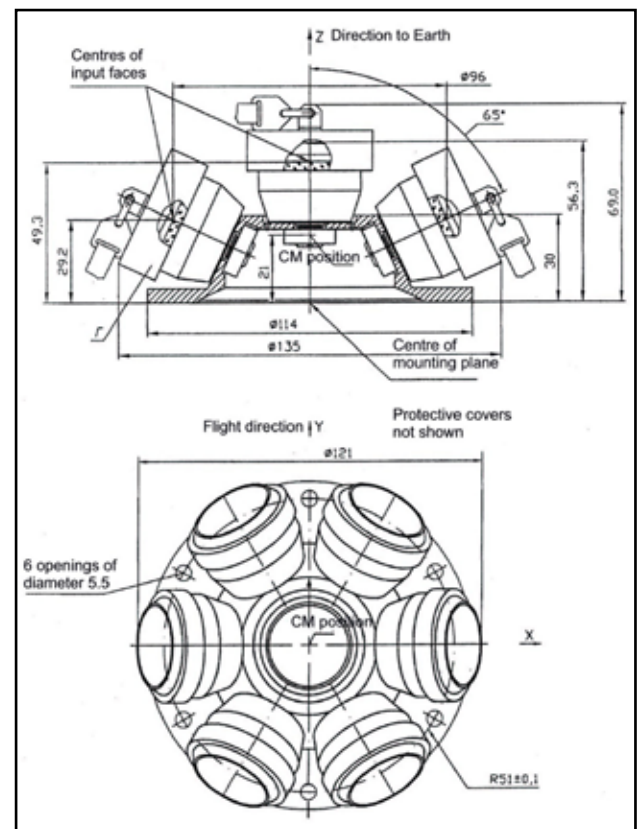

Figure 3-14. GOCE array (courtesy of ESA)

SOHLA-1

SOHLA-1 (Figure 3-15) is a technical demonstration satellite developed by local small and medium-sized enterprises in Japan with technical support from the Japan Aerospace Exploration Agency (JAXA) and Osaka Prefecture University. The main objective of SOHLA-1 is to develop and demonstrate a variety of technologies for small satellites. One example is a VHF lightning impulse system. SLR will be used for the calibration of GPS-based satellite positioning (array shown in Figure 3-16). The micro GPS receiver used in this mission has been developed by JAXA based on COTS automobile navigation technology. Launch is planned for January 2009. SLR tracking will be scheduled for short campaigns of several weeks at a time as required.

For more information see: <http://god.tksc.jaxa.jp/sohla/sohla.html>.



Figure 3-15. SOHLA-1 satellite
(courtesy of JAXA)

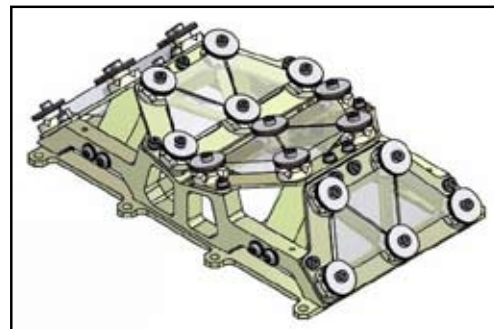

Figure 3-16. SOHLA-1 array
(courtesy of JAXA)

PROBA-2

The Project for On-Board Autonomy (PROBA) is a series of technology demonstration missions of the European Space Agency. The first satellite in the series, PROBA-1, shown in Figure 3-17, was successfully launched on 22 October 2001, initially for a two-year mission and has now been operational for five years. PROBA-2, planned for launch in the second quarter of 2009, will continue ESA's validation of new spacecraft technologies while also carrying a scientific payload. The objectives of PROBA are in-orbit demonstration and evaluation of (1) new hardware and software spacecraft technologies, (2) systems for onboard operational autonomy, and (3) instruments for Earth observation and space environment measurements. PROBA-2 carries solar observation instruments, plasma measurement instruments, a GPS receiver, and an SLR retroreflector array (Figure 3-18). SLR and GPS will provide POD.

For further information see: http://www.esa.int/esaTQM/1134728792936_index_0.html.

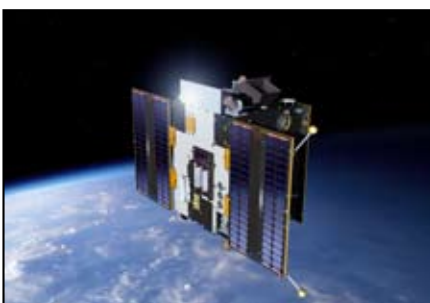

Figure 3-17. PROBA satellite
(courtesy of ESA)



Figure 3-18. PROBA array
(courtesy of ESA)

QZS-1

The Quasi-Zenith Satellite System (QZSS) is a Japanese regional satellite navigation program planned East Asia and Oceania. A two-stage system deployment is planned. As a first step, QZS-1, shown in Figure 3-19, will be launched in 2010 for technical validation and demonstration of several applications. The second step involves the launch of the second and third satellites several years later to demonstrate full system operation. JAXA and related research institutes are in charge of technology development and demonstration of the GPS complement and augmentation from QZSS.

QZSS is a three satellites constellation where each satellite is placed in the different orbital planes with inclined, geo-synchronous period and slight eccentricity. Each satellite is placed in an orbit so as to pass over the same ground track at constant intervals with at least one satellite in place near zenith over Japan at all times.

The QZSS has complete interoperability with GPS and will be worked as a GPS satellite with better geometrical position. QZS will improve availability and DOP compared with use of GPS only, especially in urban canyon and mountainous terrain. The satellite system is also a good platform for WDGPS (Wide-area Differential Global Positioning System). High elevation angle characteristics can be applied to the WDGPS platform for stable link. The target accuracy is several tens of centimeters. SLR tracking on QZS-1 is necessary to estimate navigation data biases and evaluate orbit determination accuracy; the array on QZSS is shown in Figure 3-20.

For additional information see: http://www.jaxa.jp/projects/sat/qzss/index_e.html.



Figure 3-19. QZSS satellite (courtesy of JAXA)



Figure 3-20. QZSS array (courtesy of HTSI)

STSAT-2

Science and Technology SATellite-2, being built by the Korea Advanced Institute of Science and Technology (KAIST) for development of a low earth orbit 100kg satellites, which can be launched by KSLV-1 (Korea Space Launch Vehicle-1) from the domestic space center (NARO Space Center). The mission supports the development of advanced technology for small spacecraft, and the development and operation of world-class space science payloads. STSAT-2, shown in Figure 3-21, has two payloads, a Dual-channel Radiometer for Earth and Atmosphere Monitoring system (DREAM) and a Laser Retroreflector Array). DREAM will measure brightness temperature of the Earth at 23.8 GHz and 37 GHz, for processing to obtain physical parameters such as cold liquid water and water vapor. The spacecraft technology mission objective is to develop a thermally, mechanically, electrically stable and radial resistant spacecraft system having high-precision attitude determination and control capability in a high eccentric ellipsoidal orbit.



Figure 3-21. STSAT-2 satellite and integrated array (courtesy of KAIST)

For more information see: <http://www.globalsecurity.org/space/world/rok/stsat.htm>.

ANDE

The Atmospheric Neutral Density Experiment (ANDE) flight is a mission flown by the Naval Research Laboratory to monitor the thermospheric neutral density at an altitude of 350km. The mission is scheduled to be launched from the Space Shuttle on June 16, 2009 and will measure the density and composition of the low Earth orbit atmosphere while being tracked from the ground to better predict the movement and decay of objects in orbit.

The ANDE mission consists of two spherical microsatellites (shown in Figure 3-22) fitted with retroreflectors: ANDE Active spacecraft (Castor) and the ANDE Passive spacecraft (Pollux). The satellites are identical in dimension (diameter of 19 inches), but have different masses, and will be tracked by the ILRS network as well as the Space Surveillance Network (SSN). The spheres will be in a lead-trail 400 km, 51 degree inclination orbit. Because of the difference in mass, the satellites will drift apart over time. The position observations of the satellites will permit studies on spatial and temporal variations in atmospheric drag associated with geomagnetic activity. Scientific objectives include measurements of total atmospheric density for orbit determination and collision avoidance, validation of fundamental theories on air drag modeling, and establishing a method to validate neutral/ion density and composition derived from on-board sensors.

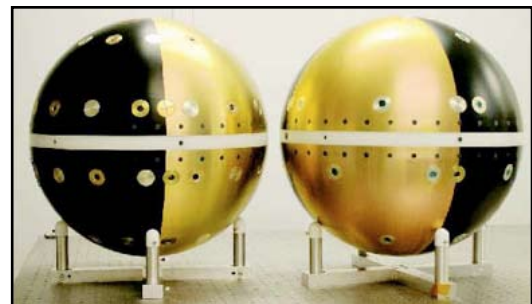

Figure 3-22. ANDE spheres (courtesy of NRL)

For additional information see: http://cdis.gsfc.nasa.gov/lw16/docs/presentations/ops_14_Thomas.pdf.

BLITS

The BLITS (Ball Lens In The Space) retroreflector satellite (Figure 3-23) has been developed and manufactured by the Science Research Institute for Precision Instrument Engineering (IPIE) in accordance with the Federal Space Program of Russia and by an agreement between the Federal Space Agency of Russia and the International Laser Ranging Service dated January 10, 2006. The purpose of the mission is experimental verification of the spherical glass retroreflector satellite concept as well as obtaining SLR data for solutions to scientific problems in geophysics, geodynamics, and relativity by millimeter and submillimeter accuracy SLR measurements. The “target error” (uncertainty of reflection center relative to the CoM position) is less than 0.1 mm, and the Earth’s magnetic field does not affect the satellite orbit and spin parameters. SLR is the only source of POD information.

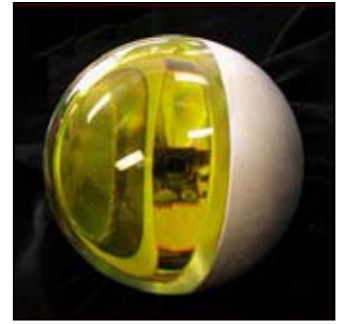

Figure 3-23. BLITS satellite (courtesy of IPIE)

The BLITS nanosatellite consists of two outer hemispheres made of a low-refraction-index glass (JK6 type) and an inner ball lens made of a high-refraction-index glass (TФ105 type). The ball lens radius is 53.52 mm; the total radius of the spherical retroreflector is 85.16 mm. The hemispheres are glued over the ball lens; the external surface of one hemisphere is covered with an aluminum coating protected by a varnish layer. All spherical surfaces are concentric. The satellite total mass is 7.53 kg. A small spherical retroreflector of the same type (6cm in diameter) was fastened to the Meteor-3M spacecraft and tested during its space flight (2001-2006).

For further information see: http://space.skyrocket.de/index_frame.htm?http://www.skyrocket.de/space/doc_sdat/blits.htm.

TanDEM-X

An additional SAR satellite (TanDEM-X) flying in tandem with TerraSAR-X will provide interferometric data for a high-accuracy global Digital Elevation Model (DEM); the tandem configuration is shown in Figure 3-24. Like TerraSAR-X, the satellite also carries the experimental Tracking, Occultation and Ranging (TOR) package provided by GFZ, which consists of a two-frequency CHAMP type GPS receiver and a CHAMP Laser Retro-Reflector (LRR, Figure 3-5). The mission’s objectives are generation of DEM (e.g., for hydrology), along-track interferometry (e.g., for measurement of ocean currents), and bi-static applications (e.g., polarimetric SAR interferometry)

High-precision orbit determination and interferometric baseline vector information of the tandem configuration will be accomplished through the TOR instrument.

For additional information see: http://www.dlr.de/hr/en/desktopdefault.aspx/tabid-2317/3669_read-5488/.

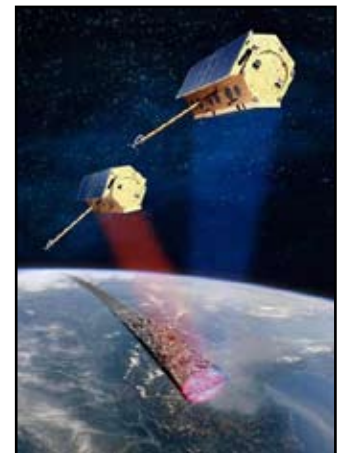

Figure 3-24. Picture of TerraSAR-X and TanDEM-X (courtesy of DLR)

LRO

The Lunar Reconnaissance Orbiter (LRO, Figure 3-25) is the first mission of the Robotic Lunar Exploration Program (RLEP). The LRO mission objective is to conduct investigations that will be specifically targeted to prepare for and support future human exploration of the Moon. This mission is currently scheduled to launch in June 2009 and is planned to take measurements of the Moon for at least one year. The measurement investigations are:

- Characterization of deep space radiation in Lunar orbit
- Geodetic global topography
- High spatial resolution hydrogen mapping
- Temperature mapping in polar shadowed regions
- Imaging of surface in permanently shadowed regions
- Identification of near-surface water ice in polar cold traps
- Assessment of features for landing sites
- Characterization of polar region lighting environment



*Figure 3-25. LRO spacecraft
(courtesy of NASA)*

The LRO Laser Ranging (LR) system will use one-way range measurements from laser ranging stations on the Earth to LRO to determine LRO position at sub-meter level with respect to Earth and the center of the Moon (on the lunar near-side or whenever possible). The LR aspect of the mission will allow for the determination of a more precise orbit than possible with S-band tracking data alone. The flight system consists of a receiver telescope, which captures the uplinked laser signal and a fiber optic cable, which routes it to the LOLA instrument. The LOLA instrument captures the time of the laser signal, records that information and provides it to the onboard LRO data system for storage and/or transmittal to the ground through the RF link.

For more information see: <http://lunar.gsfc.nasa.gov>.

SECTION 4

INFRASTRUCTURE

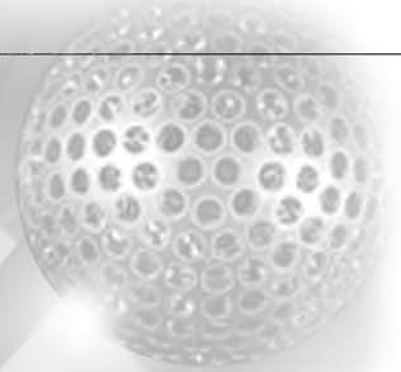

PRINCIPALS



SECTION 4

INFRASTRUCTURE

Carey Noll/GSFC

Web Site Developments

The ILRS Web site, <http://ilrs.gsfc.nasa.gov>, is the central source of information for all aspects of the service. The Web site provides information on the organization and operation of ILRS and descriptions of ILRS components, data, and products. Links are provided to extensive information on the ILRS network stations including performance assessments and data quality evaluations. Descriptions of supported satellite missions (current, future, and past) are available to aid in satellite acquisition and data analysis.

During the 2007-2008 timeframe, the Central Bureau made several improvements to the ILRS Web site. New reports and plots have been added to help monitor network performance; information is updated as needed. Station operators, analysts, and other ILRS groups can view these reports and plots to quickly ascertain stations performance as well as mission support. All plots and reports can be accessed through the station pages on the ILRS Web site at URL: <http://ilrs.gsfc.nasa.gov/stations>.

Station-Specific Performance Charts

To further aid analysis by station operators and users, the ILRS Central Bureau generates data plots summarizing station performance and environmental parameters. These plots, created for each active station in the network, are accessible through the “LAGEOS Performance” tab in the Stations Section on the ILRS Web site. These plots summarize station performance on LAGEOS including data RMS, calibration RMS, system delay, observations per normal point, and full-rate observations per pass. For each parameter, two plots are generated, one covering the last year and a second showing the information from 2000 to the present. Examples of these plots for selected stations in the network are shown in Figure 4-1.

The “Satellite Data Info” tab shows a table of plots providing statistics on all currently tracked satellites as a function of time; full-rate observations per normal point and normal point rms are also computed as a function of range and time. Examples of these satellite plots for a selected station in the network are shown in Figure 4-2. These plots are also accessible through the Satellite Missions section of the ILRS Web site (organized by mission, matrix of all stations tracking mission).

The “Meteorological Data” tab presents plots of environmental parameters: temperature, humidity, and pressure; plots spanning the last year and since 2000 are also created for this category. Examples of these met data plots are shown in Figure 4-3.

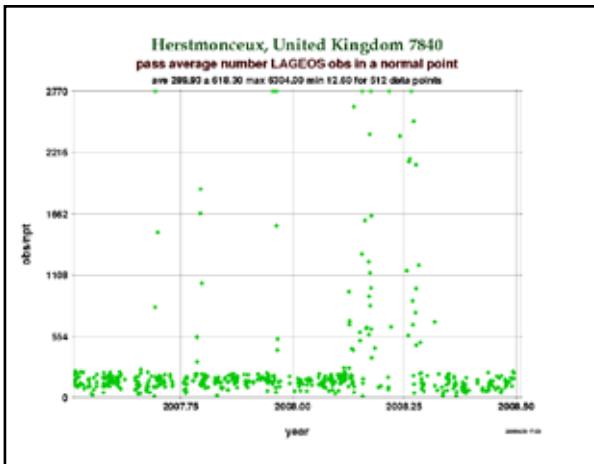

Figure 4-1a. Average number of LAGEOS observations per normal point at Herstmonceux for the past year.

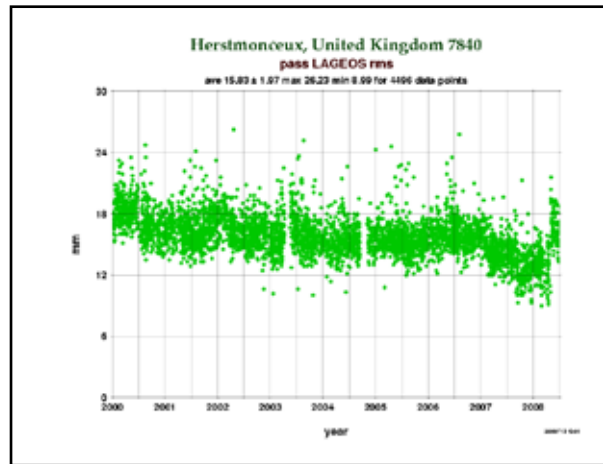

Figure 4-1b. Average LAGEOS pass RMS at Herstmonceux for the past ten years.

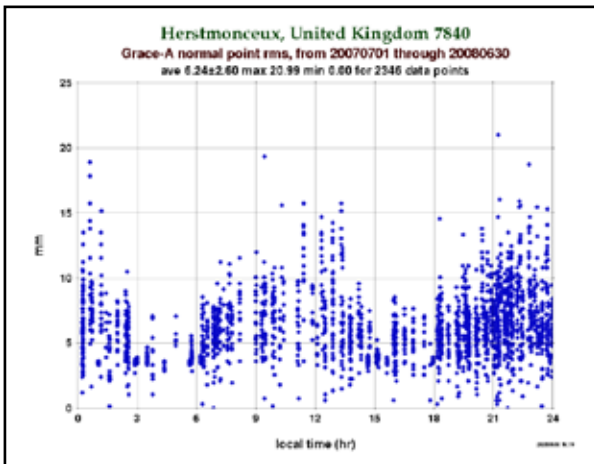

Figure 4-2a. GRACE-A normal point RMS at Herstmonceux (as a function of local time) for the past year.

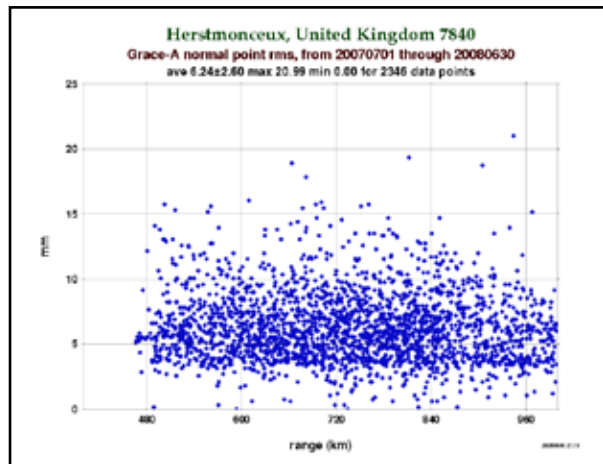

Figure 4-2b. GRACE-A normal point RMS at Herstmonceux (as a function of range) for the past year.

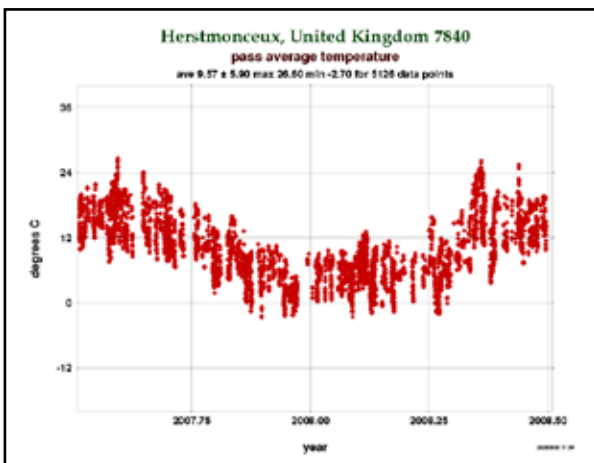

Figure 4-3a. Average temperature at Herstmonceux for the past year.

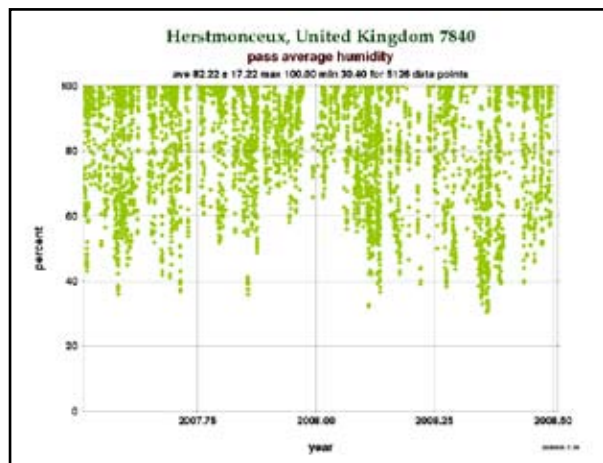

Figure 4-3b. Average humidity at Herstmonceux for the past year.

ILRS Reporting

Station Performance Report Cards

The ILRS performance “report cards” are issued quarterly by the ILRS Central Bureau (CB). These reports are issued every three months and tabulate the previous 12 months of data quality, quantity, and operational compliance by station. The statistics are presented in one set of tables (one for artificial satellites and a second for lunar reflectors) by station and sorted by total passes in descending order (Figure 4-4). Plots of data volume (passes, normal points, minutes of data) and RMS (LAGEOS, Starlette, calibration) are created from this information and available on the report card Web site. A second table (Figure 4-5) summarizes independent assessments of station performance (see example in Figure 4-6) from several of the ILRS analysis/associate analysis centers (DGFI, JCET, Hitotsubashi University, MCC, SAO). The report cards are available on the ILRS Web site at http://ilrs.gsfc.nasa.gov/stations/site_info/global_report_cards/index.html.

Site Information		Data Volume									Data Quality		
Column 1	2	3	4	5	6	7	8	9	10	11	12	13	14
Location	Station Number	LEO pass Tot	LAGEOS pass Tot	High pass Tot	Total passes	LEO NP Total	LAGEOS NP Total	High NP Total	Total NP	Minutes of Data	Cal. RMS	Star RMS	LAG RMS
Baseline		1000	400	100	1500								
Yarragadee	7090	10460	2078	1496	14034	211998	26440	13824	252262	176895	4.8	8.9	9.6
San_Juan	7406	5939	1121	1458	8518	95627	12872	9660	118159	100806	8.4	10.8	11.6
Mount_Stromlo_2	7825	5971	1246	443	7660	78010	12809	3618	94437	68583	8.9	7.6	6.2
Graz	7839	4735	653	538	5926	91480	7138	4589	103207	60632	2.1	3.4	5.2
Zimmerwald	7810	4254	830	798	5882	77529	10904	6889	95322	75844	5.0	8.0	11.0
Zimmerwald_423		266	74	46	386	5323	946	362	6631	5061			
Zimmerwald_532		3988	756	752	5496	72206	9958	6527	88691	70783	5.9	9.0	12.0
Zimmerwald_846		265	73	46	384	5243	1022	329	6594	5048			
Wetzell	8834	4453	1011	366	5830	48720	7492	1604	57816	39061	5.1	12.7	18.5
Herstmonceux	7840	3952	870	426	5248	58544	10653	1780	70977	45460	5.4	10.3	13.5
Changchun	7237	3982	605	435	5022	42011	4090	2025	48126	30121	9.1	10.9	12.4

Figure 4-4. Table 1 of the ILRS Report Card for the fourth quarter of 2008.

Site Information		DGFI Orbital Analysis				Hitotsubashi Univ. Orbital Analysis				JCET Orbital Analysis				MCC Orbital Analysis				SHAO Orbital Analysis			
Station Location	Station Number	LAG NP RMS (mm)	short term (mm)	long term (mm)	% good LAG. NP	LAG NP RMS (mm)	short term (mm)	long term (mm)	% good LAG. NP	LAG NP RMS (mm)	short term (mm)	long term (mm)	% good LAG. NP	LAG NP RMS (mm)	short term (mm)	long term (mm)	% good LAG. NP	LAG NP RMS (mm)	short term (mm)	long term (mm)	% good LAG. NP
Baseline		10.0	20.0	20.0	95	10.0	20.0	20.0	95	10.0	20.0	20.0	95	10.0	20.0	20.0	95	10.0	20.0	20.0	95
Yarragadee	7090	3.4	29.4	2.9	99.7	2.2	11.0	1.6	99.9	3.8	17.4	3.1	98.4	1.5	15.0	4.2	97.5	2.2	12.7	2.9	95.4
San_Juan	7406	6.0	37.0	6.2	99.7	3.9	20.2	9.2	99.3	6.3	16.0	3.7	93.6	3.7	16.7	10.3	96.8	4.2	26.0	11.5	94.6
Mount_Stromlo_2	7825	2.7	29.3	6.1	99.9	2.5	10.0	3.6	100.0	3.5	20.4	5.0	94.7	1.8	8.5	5.9	98.1	2.3	16.8	3.0	95.6
Graz	7839	2.2	18.9	5.4	99.8	1.3	7.6	3.0	100.0	2.4	8.9	4.9	100.0	1.9	10.9	4.2	98.7	1.5	14.1	3.4	96.2
Zimmerwald_532	7810	2.6	17.7	3.1	100.0	1.6	6.9	2.2	100.0	2.5	11.8		95.7	1.0	5.3	6.8	99.2	1.6	10.9	2.9	96.9
Wetzell	8834	3.2	30.6	7.7	100.0	2.7	11.2	2.5	100.0	3.4	18.1	3.7	91.1	1.7	10.6	1.2	97.6	1.8	16.0	3.5	95.3
Herstmonceux	7840	2.9	23.4	4.1	99.8	1.7	7.5	1.7	100.0	3.4	18.2	4.2	98.6	1.8	8.8	3.6	98.7	1.9	11.2	2.2	96.2
Changchun	7237	7.6	37.1	14.6	99.7	6.4	17.3	8.4	99.4	6.3	17.5	6.4	97.8	2.2	16.9	9.1	96.5	4.1	25.2	13.3	97.0
Riyadh	7832	3.4	35.2	5.9	99.9	2.7	13.1	5.0	100.0	3.6	20.9	7.2	100.0	1.9	15.5	7.0	96.0	3.0	26.5	9.0	95.9
Greenbelt	7105	3.2	23.9	5.7	100.0	2.1	12.8	4.8	99.9	3.1	16.6	3.2	91.7	1.6	16.9	8.1	98.0	2.0	12.7	3.6	95.3

Figure 4-5. Table 2 of the ILRS Report Card for the fourth quarter of 2008.

Example plots from the last 2008 report card are shown in Figure 4-7-a, -b, and -c.

```

# #createdAt 2008/08/13 00:31:48
#
# each line contains:
# sat = 4-char satellite name
# site = 4-char site name (CDP ID)
# date/time = pass starting time
# dur = pass duration (min)
# rb = estimated range bias (mm) with 1-sigma error
# tb = estimated time bias (microsec) with 1-sigma error
# prec = post-fit scattering rms (mm)
# bad/total = number of bad/total normal-points
# rms = single-shot rms (mm)
# pres/temp/humi = pressure (hPa), temperature (K) and humidity (%)
# sdelay = applied system delay (mm)
# shft = system delay shift (mm)
# rms = calibration single-shot rms (mm)
# cfg = system configuration flag; SCH and SCT
# r = data release flag
# wlen = laser wavelength (nm)
#
# 1824 = KIEV
# sat site date time dur rb mm error tb us error prec bad total rms pres temp hum sdelay shft rms cfg r wlen
ENVI 1824 2008/07/29 18:38 5 -141 ( 65 ) -56.2 ( 15.8 ) 28 0 / 16 41 998.6 289.1 59 16638 19 39 0 2 0 532
ERS2 1824 2008/07/29 19:09 4 -101 ( 71 ) -60.3 ( 19.5 ) 28 0 / 19 42 998.6 289.5 61 16637 14 39 0 2 0 532
ENVI 1824 2008/07/29 20:19 4 21 ( 140 ) -54.9 ( 72.5 ) 111 1 / 0 45 999.3 289.3 60 16637 14 39 0 2 0 532
ERS2 1824 2008/07/29 20:51 1 -9 ( ----- ) ----- ( ----- ) 0 1 / 2 39 999.3 288.0 61 16644 0 42 0 2 0 532
STEL 1824 2008/07/30 00:04 3 -98 ( 46 ) -33.5 ( 19.3 ) 14 0 / 9 42 999.3 286.2 71 16637 22 43 0 2 0 532
LAG1 1824 2008/07/30 00:41 2 -36 ( 79 ) ----- ( ----- ) 62 0 / 3 53 999.9 286.0 71 16638 20 43 0 2 0 532
ENVI 1824 2008/07/30 18:08 4 -25 ( 23 ) -43.2 ( 7.0 ) 5 1 / 8 42 996.6 291.4 51 16554 0 25 0 2 0 532
LAG2 1824 2008/07/30 18:37 14 223 ( 52 ) -22.4 ( 85.6 ) 14 0 / 9 69 996.7 291.3 51 16554 0 25 0 2 0 532
LAG1 1824 2008/07/30 19:09 20 178 ( 60 ) -38.1 ( 53.6 ) 32 0 / 12 58 996.8 291.3 52 16554 0 25 0 2 0 532
ENVI 1824 2008/07/30 19:46 5 -100 ( 35 ) -51.3 ( 8.8 ) 17 0 / 24 44 997.0 291.2 53 16554 0 25 0 2 0 532
ERS2 1824 2008/07/30 20:21 1 -317 ( 118 ) ----- ( ----- ) 31 0 / 6 54 997.3 290.1 53 16554 0 25 0 2 0 532
LAG1 1824 2008/07/30 22:45 22 15 ( 67 ) -74.5 ( 41.1 ) 18 1 / 11 55 997.0 288.5 59 16631 0 29 0 2 0 532
ENVI 1824 2008/07/31 19:20 1 -450 ( 14 ) ----- ( ----- ) 4 0 / 7 35 1002.6 290.6 58 16384 0 36 0 2 0 532
ERS2 1824 2008/07/31 19:45 5 -130 ( 22 ) -54.4 ( 4.3 ) 9 0 / 15 39 1002.6 290.5 59 16377 15 30 0 2 0 532
STEL 1824 2008/08/01 00:50 6 -89 ( 44 ) -29.3 ( 8.8 ) 25 0 / 14 31 1002.6 287.9 68 16364 10 28 0 2 0 532
STEL 1824 2008/08/01 01:18 3 -65 ( 50 ) -43.1 ( 21.9 ) 13 0 / 8 30 1002.6 287.7 68 16364 10 28 0 2 0 532
ENVI 1824 2008/08/01 18:45 2 -73 ( 6 ) ----- ( ----- ) 2 0 / 10 38 998.3 292.3 47 16395 0 29 0 2 0 532
.
.
.
    
```

Figure 4-6. Example of weekly station bias report from Hitotsubashi University.

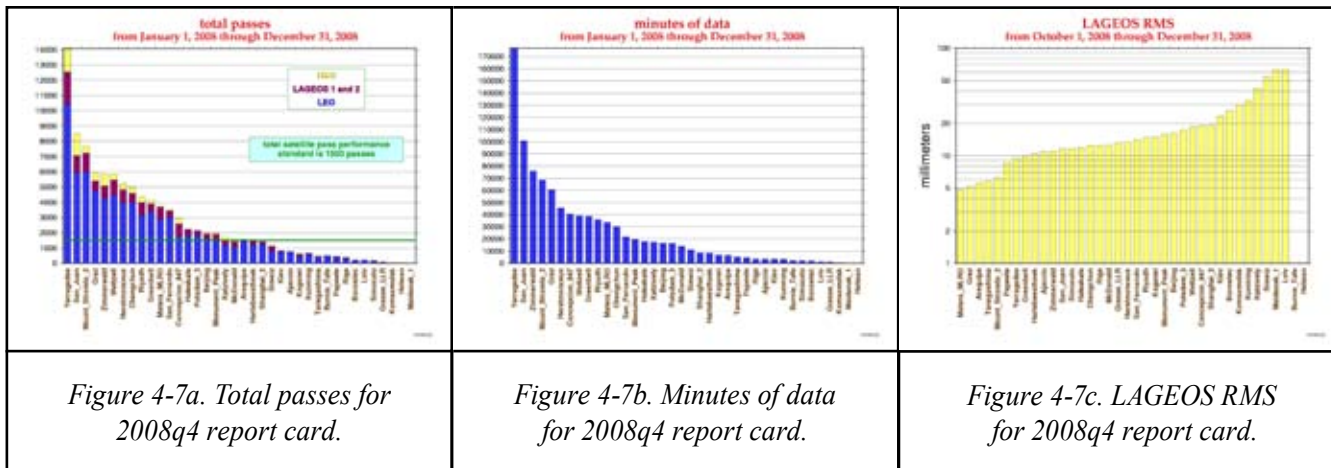

Figure 4-7a. Total passes for 2008q4 report card.

Figure 4-7b. Minutes of data for 2008q4 report card.

Figure 4-7c. LAGEOS RMS for 2008q4 report card.

The report card is used to assess the performance of the stations in the ILRS network. The Central Bureau maintains lists of the operational and associate stations, classified according to the results posted in the ILRS report cards. Performance guidelines, defined on the ILRS Web site, cover yearly data quantity (number of passes), data quality (normal point precision and short and long term bias stability) and operational compliance factors (timely data delivery, correct data formatting, required station documentation). Current operational vs. associate status can be viewed on the ILRS Web site at: <http://ilrs.gsfc.nasa.gov/stations/>.

Real-Time Daily Station Status Reports

Station status information is available on a daily and near-real time basis through the EUROSTAT utility. These reports allow the ILRS community to quickly view the status of the stations in the tracking network. ILRS stations can automatically upload status information to EUROSTAT (maintained by the Astronomical Institute of the University of Berne, AIUB) that is then used to generate an overview of the current activities of the tracking stations. The real-time report (Figure 4-8) shows actual station operations at that point in time. The daily report (Figure 4-9) provides a one-line entry per day showing if stations are currently staffed, operational, off-shift, off-line because of system problems, etc. The ILRS encourages all stations in the network to participate in the daily and, if possible, real-time exchange of status information so that experience can be shared in a timeframe to help performance other stations.

Station Name	Date	Time	Station	Status	Count	HTS	Value
Ftlrs_Ajacci	2008-09-17	19:57:33	lageos1	CUR	0	HTS7611	0.000
Herstmonceux	2008-09-17	19:56:56		OUT			
Potsdam-3	2008-09-17	19:57:01		OUT			
San_Fernando	2008-09-17	19:57:36		OUT			
Wettzell	2008-09-17	19:57:11	Larets	LST	36	HTS7611	0.000
Yarragadee	2008-09-17	19:57:40	Lageos2	CUR	2	HTS7601	0.000
Zimmerwald	2008-09-17	19:57:48	Lageos1	CUR	8405	HTS7611	0.000 (auto)

Figure 4-8. EUROSTAT real-time station status report.

DOY	Date	BURF	CONL	FTLR	GRZL	HERL	MATM	MDOL	POT3	POTS	SFEL	TEST	WETL	YARL	ZIML
261	17-Sep-2008		OUT	OPER	OPER	OPER	OPER		OPER		OUT		OPER	OPER	OPER
260	16-Sep-2008		OUT	OPER	OPER	OPER	OUT	OPER	OPER		OPER		OPER	OPER	DOWN
259	15-Sep-2008		OUT	OPER	OUT	OPER	OPER		OPER		OPER		OPER	OPER	DOWN
258	14-Sep-2008			OPER	OUT	OPER			OUT		OPER		OPER	OPER	DOWN
257	13-Sep-2008			OPER	OUT	OPER	OPER		OPER		OPER		OPER	OPER	DOWN
256	12-Sep-2008			OPER	OPER	OPER	OPER		OPER		OPER		OPER	OPER	DOWN
255	11-Sep-2008			OPER		OPER	OPER		OPER		OPER		OPER	OPER	OPER
254	10-Sep-2008					OPER	OPER		OPER		OPER		OPER	OPER	OPER
253	09-Sep-2008					OPER	OPER		OPER		OPER		OPER	OPER	OPER
252	08-Sep-2008		OUT			OPER	OPER		OPER		OPER		OPER	OPER	OPER
251	07-Sep-2008					OUT	OPER		OPER				OPER	OPER	OPER

Figure 4-9. Daily station status report (for Sept. 17, 2008).

ILRS 2005-2006 Report

The 2005-2006 ILRS Report was issued and can be viewed on the ILRS Web site (http://ilrs.gsfc.nasa.gov/reports/ilrs_reports/ilrsreport_2005.html). ILRS analysis center reports and inputs are used by the Central Bureau for weekly review of station performance and to provide feedback to the stations when necessary. These reports as well as special weekly reports on on-going campaigns are issued by e-mail. A catalogue of diagnostic methods, for use along the entire data chain starting with data collection at the stations, has emerged from this process and will be made available on the ILRS Web site. The evaluation process has been helpful in comparing results from different analysis and associate analysis centers, a role soon to be assumed by the Analysis Working Group.

Data Center Developments

The archives of the ILRS data centers at CDDIS and EDC were updated to include new products generated by the ILRS Analysis Centers. These products currently under evaluation included daily “pos+eop” SINEX solutions and derived orbits from selected satellites.

The data centers, as well as the entire ILRS infrastructure, transitioned to a new format for satellite predictions, the Consolidated Prediction Format (CPF). Predictions in the older Tuned IRV format were discontinued in late 2007.

The ILRS also introduced the Consolidated Ranging Data (CRD) format during 2008. CRD provides a flexible, extensible format for ILRS full-rate, sampled engineering, and normal point data. The new format will accommodate new missions, e.g., transponder experiments, and station capabilities such as high-repetition rate lasers. The data centers began support of CRD tests by creating directories and updating data flow procedures. The complete transfer to the CRD format is scheduled for early 2010.

SECTION 5

TRACKING PROCEDURES AND DATA FLOW

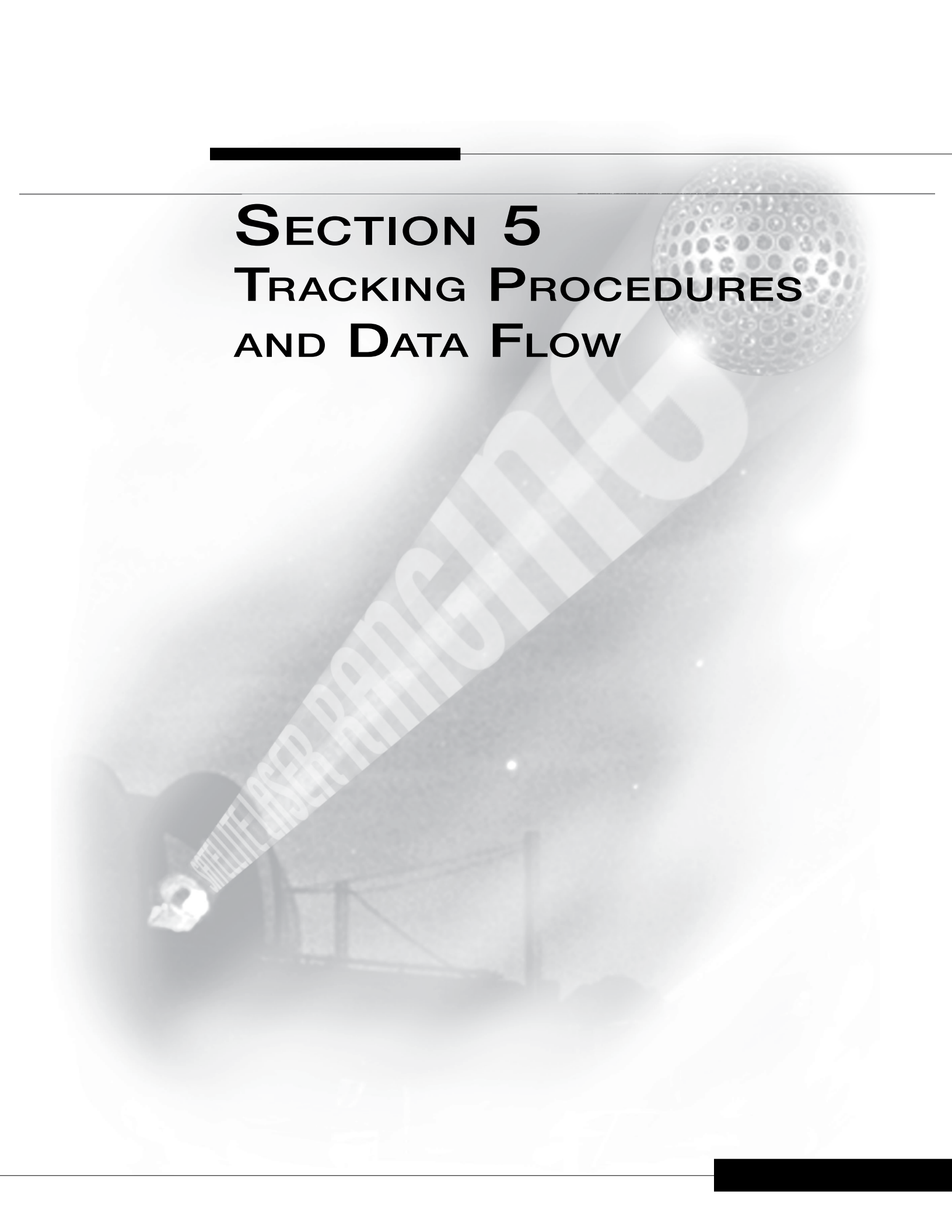
The background of the page is a grayscale photograph of a soccer field at night. In the foreground, a soccer ball is visible on the right side. The field is illuminated by stadium lights, creating a hazy atmosphere. A large, semi-transparent watermark reading "EASED PRACTICE" is oriented diagonally across the center of the image. The text "SECTION 5 TRACKING PROCEDURES AND DATA FLOW" is positioned in the upper left quadrant of the page.

SECTION 5

TRACKING PROCEDURES AND DATA FLOW

Carey Noll/NASA GSFC

Tracking Priorities

The ILRS tries to order its tracking priorities (shown in Table 5-1) to maximize the utility to the users of ILRS data. Nominally tracking priorities decrease with increasing orbital altitude and increasing orbital inclination (at a given altitude). Priorities for some satellites are then increased to intensify support for active missions (such as altimetry), special campaigns (such as satellite in eclipsing orbit), and post-launch intensive tracking campaigns. Some slight reordering may then be given missions with increased importance to the analysis community. Some tandem missions (e.g., GRACE-A and -B) may be tracked on alternate passes at the request of the sponsor. Stations may also adjust priorities to accommodate local conditions such as system capabilities, weather, and special program interests.

Table 5-1. Satellite and Lunar Tracking Priorities (as of December 2008)

Satellite Priorities					
Priority	Satellite	Sponsor	Altitude (km)	Inclination (degrees)	Comments
1	GRACE-A/B	GFZ, JPL	485-500	89	Tandem mission
2	CHAMP	GFZ	429-474	87.3	
3	TerraSAR-X	Infoterra/DLR/GFZ/CSR	514	87.27	
4	Envisat	ESA	796	98.6	Tandem mission with ERS-2
5	ERS-2	ESA	800	98.6	Tandem mission with Envisat
6	Jason-1	NASA, CNES	1,350	66.0	Tandem mission with Jason-2
7	Jason-2	NASA, CNES, Eumetsat, NOAA	1,336	66.0	Tandem mission with Jason-1
8	OICETS	JAXA	610	97.83	
	Larets	IPIE	691	98.2	
10	Starlette	CNES	815-1,100	49.8	
11	Stella	CNES	815	98.6	
12	Ajisai	JAXA	1,485	50	
13	LAGEOS-2	ASI, NASA	5,625	52.6	
14	LAGEOS-1	NASA	5,850	109.8	
15	BE-C	NASA	950-1,300	41	
16	Etalon-1	Russian Federation	19,100	65.3	
17	Etalon-2	Russian Federation	19,100	65.2	

18	Compass-M1	China	21,500	55.5	
19	GLONASS-99	Russian Federation	19,400	65	Replaced GLONASS-87 (12-Jan-2007)
20	GLONASS-109	Russian Federation	19,400	65	Replaced GLONASS-95 (28-May-2008)
21	GLONASS-102	Russian Federation	19,400	65	Replaced GLONASS-89 (04-May-2007)
22	GPS-35	U.S. DoD	20,100	54.2	
23	GPS-36	U.S. DoD	20,100	55.0	
24	GIOVE-B	ESA	23,916	56	
25	GIOVE-A	ESA	29,601	56	

Lunar Priorities

Priority	Retroreflector Array	Sponsor	Altitude (km)
1	Apollo 15	NASA	356,400
2	Apollo 11	NASA	356,400
3	Apollo 14	NASA	356,400
4	Luna 21	Russian Federation	356,400
5	Luna 17	Russian Federation	356,400

Tracking priorities are formally reviewed semi-annually by the ILRS Governing Board. Updates are made as necessary. The Central Bureau communicates these updates to the ILRS stations.

Predictions

Current Status

There are now ten centers that provide SLR predictions on a regular basis (see Table 5-2).

The consolidated laser ranging prediction format (see below) is now operational within the ILRS. This format can be used for ranging to near Earth satellites and the Moon, and for transponder ranging to planets and interplanetary spacecraft. Also included are options for standardizing prediction interpolators used at the stations. In 2006, the tracking of very low Earth orbit satellites increased significantly with sub-daily distribution of the new, higher quality CPF predictions.

The ILRS is encouraging stations to use the mission provided or sanctioned predictions for these satellites where they are available. Some of the recent missions have periodic maneuvers or drag compensation capability, and some also have GPS data to enhance the SLR predictions. Since the missions have the most up-to-date information of this type, they are in the best position to keep predictions current.

Table 5-2. Satellite Prediction Providers

Center	Interval	Satellites
CNES	Daily	Jason
CODE	Daily	GLONASS, GPS
ESOC	Daily	Envisat, ERS-2, GIOVE
GFZ	Sub-daily	GRACE, CHAMP, TerraSAR-X
HTSI	Daily	Ajisai, BE-C, Compass-M1, Envisat, ERS-2, Etalon, GIOVE, GLONASS, GPS, Jason, LAGEOS, Larets, Starlette, Stella
JAXA	Daily	Ajisai, ALOS LAGEOS, OICETS, ETS-8
MCC	Daily	Larets
NSGF	Daily	Ajisai, BE-C, Envisat, ERS-2, Etalon, Jason, LAGEOS, Larets, Starlette, Stella
NRL	Sub-daily	ANDE-RR
SAO	Sub-weekly	Compass-M1
UTX	Daily	ICESat, Moon

Consolidated Prediction Format (CPF)

Randy Ricklefs/University of Texas at Austin, CSR

The ILRS Governing Board approved the new Consolidated Prediction Format (CPF) in October 2005, and since then all operating stations have been converted to use this new format. There is also an ongoing effort to implement the CPF for laser ranging support of the first transponder mission to the Moon, the Lunar Reconnaissance Orbiter (LRO).

Restricted Tracking on Vulnerable Satellites

Michael Pearlman/CfA, Randy Ricklefs/University of Texas at Austin, CSR, Julie Horvath/HTSI

During the last two years, network procedures have been implemented to protect satellites that are vulnerable to laser radiation. Satellites such as ICESat and ALOS have optical sensors aboard that could be damaged. Restricted satellite missions may opt to request one, two, or all of the possible restrictions for their mission, but the numbers 1 and 5 below are required procedures. The procedures include:

1. Predictions are sent to only participating (qualified) stations;
2. Stations are restricted to a maximum ranging elevation to protect fixed nadir pointing sensor(s);
3. Missions provide allowable pass segment files to carefully define tracking and non-tracking periods;
4. Stations are constrained by a mission provided, Web accessible GO/NO-GO flag which allows immediate (within 5 minutes) cessation of all network tracking of target;
5. Stations can also be constrained to a mission-defined maximum power delivered to the spacecraft; and
6. Participation is limited to trusted stations that have demonstrated ability to handle the pass segment file and GO/NO-GO flag.

Among the ILRS stations that have implemented these procedures include: Mt. Stromlo, Riga, Koganei, Monument Peak, Hartebeesthoek, Yarragadee, Tanegashima, Zimmerwald, Herstmonceux, Greenbelt, and TLRS-4 (Haleakala). A questionnaire is being developed to learn which stations have implemented which restrictions. ICESat is presently operating under restricted tracking conditions.

Data Transmission

The ILRS continues to improve data throughput. Data from the field stations are now submitted hourly and made available immediately through the data centers for rapid access by the user community and prediction providers. With this faster submission of data, better quality predictions are available more frequently and prediction quality assessment is available in near real-time.

Consolidated Laser Ranging Data Format (CRD)

Randy Ricklefs/University of Texas at Austin, CSR

Due to the one-way laser ranging support of the Lunar Reconnaissance Orbiter (LRO) mission, and the growing number of stations with lasers firing at a kilohertz rate, the Data Formats and Procedures Working Group has rewritten the formats for the ILRS full-rate, normal point, and sampled engineering data types. The older formats do not allow for many of the fields or field sizes required for ranging to transponders. In addition, the current full-rate format is too cumbersome for the amount of data produced by kilohertz laser ranging. The new format encompasses all three data types for SLR, LLR, and transponder targets. The Consolidated Laser Ranging Data (CRD) format uses the same building block approach as the Consolidated Prediction Format (CPF), which allows modularity, flexibility, and expandability. Since the CRD format is considerably more complicated than the old formats, a process was developed by which the ILRS Operations Centers (OCs) at EDC and NASA/HTSI and the AWG would validate CRD normal points from each station. Once a station's data are validated, the station will submit data only in the CRD format. As of the end of 2008, at least MLRS, Mt. Stromlo, Changchun, Wettzell, Matera, and Herstmonceux were providing normal points to the ILRS in CRD format (as well as the old format), and the process of validating the stations had begun. At the same time, many of these stations, plus Zimmerwald and Grasse were producing full-rate data in CRD format, primarily for support of the T2L2 experiment on Jason-2.

SECTION 6

EMERGING TECHNOLOGIES



SECTION 6

EMERGING TECHNOLOGIES

John Degnan/Sigma Space Corporation

Introduction

This report is largely, but not exclusively, based on the technical papers presented at the 16th International Workshop on Laser Ranging, held in Poznan, Poland in October, 2008. The report also draws on material from external sources. It is not intended as a review of all that was presented, since the online abstracts and papers do that adequately. Instead, it is a subjective attempt to organize, summarize and comment on the key technology trends and highlights (hardware only) and to tie key engineering activities into an overall perspective. .

Kilohertz Photon-Counting Systems

Eyesafe Systems

NASA researchers reported on the operational status of the Next Generation Satellite Laser Ranging (NGSLR) system, formerly known as SLR2000 [McGarry et al, 2008]. Using a transmitted eyesafe energy of only 60 μJ , the system has routinely tracked LEOs down to 10° elevation and LAGEOS to 30° elevation. The system has also successfully ranged to GLONASS at high elevations. Starcals are now totally automated, and a new short pulse laser is being developed at GSFC, which will provide a capability to change repetition rate and pulse energy over a wide range to access the highest satellites in non-eyesafe mode. Routine daylight tracking was initiated following successful implementation of a dual Risley prism device to point the transmitter ahead of the receiver [Degnan et al, 2008]. The automated fine pointing of the receiver using the quadrant detector has proven more difficult than anticipated due to an inability to date to acquire the necessary stability in the relative response of the four quadrants (see Section 5.2 for other modifications.).

Non-Eyesafe Systems

Graz reported on results from a new “skin-tracking” approach for determining the satellite orbit using kHz data. They were able to reduce the scatter of their normal points from several cm to less than 1 mm by only accepting returns from the leading edge (LE) to LE+20 mm [Kirchner et al, 2008b].

Because the Graz ET requires 400 μsec to fix an event time, they have recently developed a medium resolution (~250 psec) ET with a much faster 20 nsec response to set their new 500 psec resolution Range Gate Generator (RGG) [Iqbal et al, 2008].

Transitional or New Sub-kHz Systems

UK researchers at Herstmonceux continue to operate in a dual mode, i.e. the older 10 Hz system and the newer 2 kHz system. [Gibbs et al, 2008]. They generally report higher precision results with 2 kHz but still have some difficulty dealing with solar count rates that are significantly higher than the satellite return rates, especially high altitude satellites with broad impulse responses such as Etalon. However, the dual mode operation, like NGSLR, allows them to participate in transponder experiments to the LRO spacecraft.

The Chinese stations in Shanghai [Zhang et al, 2008] and Changchun [Fan et al, 2008] have both demonstrated an ability to operate in the kHz regime using long pulse (40 – 50 nsec) test lasers and are planning to install subnanosecond kHz lasers in the near future. Within the next two years, it is expected that all of the Chinese SLR stations, with the exception of Kunming, will go to 2 kHz operations. [Yang et al, 2008a].

The Swiss Zimmerwald station reported on their experiences with a 100 Hz, 40 psec pulse, 8 mJ transmitter at 532 nm [Gurtner et al, 2008]. They were able to achieve a 13% return rate on high altitude GNSS satellites using a rotating mechanical transmit/receive (T/R) switch for backscatter protection at the lower rate.

The Russian delegation reported on the new 300 Hz system at their Altay site which started providing data to the ILRS in October, 2008 [Burmistrov et al, 2008]. The laser outputs 2.5 mJ of energy in a 150 psec pulse.

Other Applications of kHz Data

Graz is presently using the atmospheric backscatter from their SL transmitter to run a parallel cloud detection lidar with a 15 m range resolution. To date, it has measured cloud heights up to 10 km [Kirchner et al, 2008a].

Some preliminary experiments were reported where the photon-counting kHz system at Herstmonceux was used to measure the impulse response of satellites already in space [Otsubo et al, 2008]. The method takes advantage of the bias-free nature of photon-counting systems. However, the measured profile must be deconvolved with the instrument impulse response to obtain the satellite response.

Components

Detectors

The vastly different recovery times, following a photon event, of Single Photon Avalanche Diodes (SPAD) and MicroChannel Plate PhotoMultiplierTubes (MCP/PMTs) can have important consequences for photon-counting systems operating in daylight [Degnan, 2008b]. Recovery times range from about 1.6 microseconds for a passively quenched SPAD (PQ-SPAD), to about 50 nsec for an Actively-Quenched SPAD (AQ-SPAD), to less than 2 nsec for an MCP/PMT. The fast recovery time (or short deadtime) of the MCP/PMT results from the fact that an incoming photon depletes only a small subset of microchannels in the vicinity of the strike. Hence, there are thousands of remaining high gain microchannels available for recording subsequent photons. With high solar backgrounds, long deadtimes can significantly reduce the signal count rate from the satellite. Thus, every effort must be made to reduce the solar count rate through the use of spectral and spatial filtering. Temporal filtering or gating can reduce the number of solar counts observed but does not increase the signal count rate. In NASA's NGSLR system, use of a Dual Risley Prism system to compensate for transmitter point-ahead allows a substantial reduction in the receiver FOV [Degnan et al, 2008].

If the combined recovery time of the detector and range receiver is slow compared to the solar background rate, most or all of the satellite returns will not be observed. As a case in point, NASA's NGSLR system incorporates a low deadtime (<2 nsec) Quadrant MCP/PMT but, since all four quadrant channels outputs are combined into a single input channel of the HTSI Event Timer with a deadtime of 60 nsec, the overall system response is no better than that of an AQ-SPAD. For the purposes of SLR, the PQ-SPAD is a single stop device, and thus a single solar photon appearing within a typical range gate can prevent the system from seeing the satellite return.

The Compensated SPAD (C-SPAD) is the photon-counting detector used at the kHz Graz and Herstmonceux stations. The Herstmonceux group [Wilkinson et al, 2008] estimates that the loss for LAGEOS and HEO satellites during daylight C-SPAD operations ranges from 20% to 50% of the total shots fired. Furthermore, since the C-SPAD must be armed 50 to 100 nsec before an observation to avoid any range bias, Herstmonceux researchers experimented with a high speed Pockels Cell shutter designed to shield the C-SPAD from noise counts within the spectral filter

passband until about 10 nsec before the expected satellite return. Unfortunately, the polarization losses are high (50%) and alternative polarization-insensitive switching schemes are either too slow or have other technical issues [Wilkinson, 2008]. In a similar vein, Czech researchers [Prochazka and Blazej, 2008] reported on several SPAD detectors developed for Laser Time Transfer and one-way ranging experiments (see Section 5 of this report). Their ability to operate under high solar background conditions appears to be largely due to a fast gating capability (<30 nsec before the expected event), but this assumes extremely accurate prior knowledge of when the event will occur, which will not always be the case in future interplanetary transponder or altimetry missions. In simple terms, the uncertainty of the signal photon arrival time must be very small compared to the mean interval between background photons for the Herstmonceux Pockels Cell approach or new Czech detector to be viable. On the other hand, it has already been demonstrated that range receivers using MCP/PMTs can record multiple photon events within a wide temporal gate with a deadtime of only 1.6 nsec [Degnan, 2008b]. MCP/PMTs also have lower dark count rates than SPADs and Herstmonceux is preparing to conduct experiments with them.

Other recent detector developments not reported at the Workshop include a new infrared MCP/PMT available from Hamamatsu (Japan) and a segmented anode SPAD array sold by SENSL (Ireland). Hamamatsu guarantees 10% QE and has achieved as high as 18% QE at wavelengths 1064 nm and beyond. The new tube is somewhat bulkier, requires more cooling, has a higher dark count rate, and is less technologically mature than its visible counterpart, but the significant efficiency improvement over prior NIR photon-counting devices (18% vs 3%) certainly improves the competitiveness of NIR systems. The SENSL device, operating in the visible, attempts to confer some of the advantages of MCP/PMT devices to SPAD arrays. The fast recovery of MCP/PMTs is due to the fact that a photon incident on the photocathode only depletes a small number of microchannels in the vicinity of the strike, leaving thousands of other microchannels available for subsequent photon “hits”. The common anode was then able to sum the output of the various microchannels for an effective “zero” deadtime [Degnan, 2008b]. Similarly, a common anode in the new SENSL device sums the outputs of individual SPADs and significantly reduces the number of timing channels required to record the various photon events. Further mimicking MCP/PMTs, the company also provides multi-anode versions of the SPAD arrays. A preliminary look at these devices, however, suggests that output pulse rise times are too long for precise ranging but the technology may merit further consideration since SPADs, unlike MCP/PMTs, do not have life-limiting mechanisms related to total charge transfer.

Precision Timing

Latvian researchers reported on the status of their latest event timer, the Model A033-ET. The principal focus is on replacing outdated components on their earlier A032-ET and making it a commercially viable product [Artyukh et al, 2008]. The updated unit consumes less than 6W of power, has a single NIM input, a resolution of less than 4 psec, and a 40 nsec deadtime.

Another Latvian group reported on a High Speed Event Timer based on the commercially available Time-to-Digital Converter (TDC) chips [Boole and Vedin, 2008]. The principal features include 6 independent event measurement channels (4 primary and 2 TAG channels), 90 psec RMS resolution at rates up to 5 MHz, and a 6.5 nsec deadtime.

Czech researchers reported on their New Precision Event Timer (N-PET), which uses a novel and recently patented Surface Acoustic Wave (SAW) filter excitation as a time interpolator [Prochazka and Panek, 2008]. In addition to a 0.9 psec RMS timing precision, the authors claim high timing linearity (+0.2 psec nonlinearity over the interpolator range) and a low temperature drift (<0.3 psec/K). However, like the venerable French Dassault ET, the N-PET has an extremely long dead time (~10 msec) which limits its usefulness in certain applications and operational environments.

Laser Transmitters

Picosecond, Kilohertz Lasers

The Austrian firm, High-Q Lasers, gave an overview of their ultrashort pulse laser products, which span the femtosecond and picoseconds regimes. [Huber et al, 2008]. The kHz stations in Graz and Herstmonceux presently use their pico-REGEN system, which produces nominal 10 psec pulses at 2 kHz with a single pulse output energy of about 0.4 mJ. The company achieves this performance through the use of a modelocked oscillator (to obtain short but very low energy pulses) and a regenerative amplifier which boosts the energy by many orders of magnitude via a large number of passes through the amplifier before the circulating pulse is switched out. Some scientific users are requesting higher energies in the few mJ range, and the company is presently working on two strategies: (1) the use of a post-amplifier in their standard Nd:Vanadate system; and (2) moving to a different laser material, such as Nd:YLF. The Zimmerwald station recently installed a 100 Hz, 40 psec, 8.3 mJ (@ 532 nm) transmitter composed of a SESAM (SEmiconductor Saturable Absorber Mirror) oscillator, a regenerative amplifier, double pass amplifier, and doubling crystal [Gurtner et al, 2008].

The principal drawback of modelocked oscillators and regenerative amplifiers for some ranging applications is their relatively large size (long oscillator and regenerative amplifier optical lengths are typically required) and their relative complexity (e.g. high voltage electro-optic switches operating at kHz rates in the regenerative amplifier). Their principal competition as transmitters for kHz SLR systems is the passively Q-switched microchip laser followed by one or more passive amplifiers in a Master Oscillator Power Amplifier(s) (MOPA) configuration, as is presently used in NASA's eyesafe NGSLR system. While much more compact and energy efficient (and therefore better suited to spaceborne transponder and airborne altimetry applications), microchip oscillators to date have difficulty generating pulses much shorter than about 250 psec at the required energies. Using (SESAMs) as the passive switching media in a quasi-monolithic microchip laser, European researchers [Nodop et al, 2007] recently produced pulsewidths as short as 50 psec at repetition rates up to 40 kHz. The single pulse energy (~1 μ J) was substantially lower than that obtained from conventional Cr⁴⁺:YAG-switched microchips but roughly three orders of magnitude greater than typical CW pumped modelocked oscillators. One would expect future transmitters based on similar oscillators, perhaps coupled into fiber amplifiers for the initial stage of amplification, to provide shorter pulsewidths than conventional microchips and be much smaller, lighter, more power efficient, and less complex than modelocked oscillator/regenerative amplifier combinations.

Other Laser Developments

HTSI reported on modifications to the NASA MOBLAS acousto-optically and passively modelocked Pulse Transmission Mode (PTM) laser oscillator [Oldham et al, 2008]. The original laser used both an Acousto-Optic Modulator (AOM) and a passive modelocking dye to generate the short pulses. An internal electro-optic switch (Pockels cell) switched the pulse out at or near its peak intensity to produce several mJ of output. Since the dye and its solvent presented somewhat of a biohazard and needed to be replaced periodically, the HTSI engineers looked at two alternatives – a Saturable Absorber Mirror (SAM) and a bulk Cr⁴⁺:YAG passive modelocker (PM). With the SAM substituting for the dye, the output energy was low (~nJ) and unstable whereas the PM produced a stable, higher energy pulse (mJ) pulse, especially when it was located close to the active modelocker. An internal etalon was used to select a particular pulsewidth. The modifications are scheduled to be implemented in all of the NASA MOBLAS and TLRS systems as well as MLRS.

Australian researchers reported an increase in productivity at their Mt. Stromlo station following a 3-fold increase in the power of the laser transmitter – from 0.4 W (13 mJ @ 30 Hz) to 1.2W (20 mJ@60 Hz) [Moore, 2008].

Multi-Wavelength Ranging

To the author's knowledge, no new hardware or atmospheric model related activity in this area was reported at the Poznan workshop or elsewhere in the literature during this period.

Lunar and Interplanetary ranging

Lunar Laser Ranging (LLR)

Progress toward 1 mm lunar ranging precision continues to be made at the Apache Point Observatory for Lunar Laser Operations (APOLLO) [Murphy et al, 2008b]. Single pulse returns as high as 10 photoelectrons and high return rates have been obtained with a modestly powered laser transmitter (115 mJ @ 20 Hz) thanks to an exceptionally large 3.5 m telescope aperture and a high QE 4 x4 detector array provided by MIT Lincoln Laboratories. Nevertheless, returns are 100 times weaker than expected at or near Full Moon and approximately 10 times weaker overall. APOLLO researchers do not believe this discrepancy is due to the increased solar background.

French researchers reported on the status of their new MeO system, which will be dedicated to tracking satellites from 400 km to the Moon [Samain et al, 2008a]. First satellite echoes were obtained in July 2008 with the first lunar attempts scheduled for November 2008.

Lunar Reconnaissance Orbiter (LRO)

Several research groups reported on activities related to the first operational laser tracking of a satellite in lunar orbit, Lunar Reconnaissance Orbiter (LRO). Ground SLR stations will fire at the LRO spacecraft and a one inch diameter telescope, mounted on the spacecraft microwave antenna, will collect the photons and relay the photons to one of four ranging channels on the Lunar Orbiter Laser Altimeter (LOLA) instrument. The received energy must be sufficient to trigger the onboard detector. Furthermore, since the channel is shared by laser ranging and altimetry functions, the ground laser fires must be timed precisely so that they enter the LOLA range gate within a narrow 8 msec interval at maximum rates of 28 Hz, corresponding to the altimeter laser fire rate. The purpose of the one-way SLR tracking is to improve knowledge of the lunar gravitational field and LRO orbital precision [Smith et al, 2008a].

In order to support the LRO experiment from the new NGSLR station, NASA researchers have added a higher energy (50 mJ), longer pulse (6 nsec), low repetition rate (28 Hz) transmitter option which shares the NGSLR telescope and tracking mount for uplink only ranging to LRO [McGarry et al, 2008]. The transition between eyesafe 2 kHz and non-eyesafe 28 Hz operation is accomplished with a simple drop-in mirror and toggle switch. A standard NASA aircraft radar was also added to support high energy ranging to LRO. An overview of the comprehensive pre-launch testing program at NGSLR was also provided at the Poznan workshop [Mallama et al, 2008]. Preparations for LRO tracking by the MLRS LLR station in Texas were also described [Wiant et al, 2008].

Czech researchers reported on a pocket-sized device which can be used for precise epoch timing unit (130 psec RMS) and control laser time of fire with a resolution of 100 nsec in one way laser ranging experiments [Kodet and Prochazka, 2008].

Interplanetary Laser Transponders

US researchers from a variety of collaborating institutions reported on a recent scientific and technology study of a laser transponder mission to Mars, or alternatively the Martian moon Phobos [Murphy et al, 2008a]. Scientific interest centers on the study of gravity, especially as it pertains to General Relativity. Millimeter accuracy ranging over interplanetary distances can provide orders of magnitude better precision in the measurement of key relativistic parameters. The technology portion of the study, carried out largely at NASA's Jet Propulsion Laboratory (JPL),

proposes a 3 year mission. A telescope aperture of 12 cm and a transmitter power of 250 mW are proposed for the spaceborne terminal. The nominal Earth terminal would have a 1 m telescope and transmit 3 mJ, 12 psec pulses at kHz rates.

German researchers [Schreiber et al, 2008] reported on the first experimental attempt to simulate an interplanetary transponder link using the dual station ranging technique [Degnan, 2006]. A small transceiver package (AltiDemon) was operated alongside the Wetzell SLR system, with each system observing the reflected pulses of the other. The experimenters used the ERS, Ajisai, and LAGEOS satellites to simulate a link between Earth and its nearest planetary neighbors, Mars and Venus..

Laser Time Transfer

The long awaited French T2L2 (Time Transfer by Laser Link) experiment was launched onboard the Jason-2 spacecraft in June 2008. Fundamental physics goals include measurement of the anisotropy of the speed of light and validation of the one way laser ranging concept [Samain et al, 2008b]. As of the workshop, 15 SLR stations had met the requirements for participation in the experiment,

Chinese and Czech researchers reported on the results of their joint Laser Time Transfer (LTT) experiment on the Compass-M1 spacecraft, which was launched into a 21,500 km high orbit in April 2007 [Yang et al, 2008b]. The time difference between the ground hydrogen maser and the spaceborne rubidium clocks was made by the Changchun SLR station with a single pulse precision of 300 psec. The measured frequency drift and stability of the spaceborne rubidiums were 1.47×10^{-10} and 10^{-13} respectively. The uncertainty in the relative frequency difference is about 3×10^{-14} averaged over 2000 seconds. Solar noise corrupted the measurements, and the best results were obtained during night operations.

In a somewhat different vein, Spanish researchers have used SLR range measurements to Galileo GIOVE-B to decouple the radial error in the orbit from onboard clock offsets, which are highly correlated [Hidalgo et al, 2008].

Laser Altimetry

US researchers reported on recent results obtained with a 2nd generation photon-counting 3D imaging lidar and discussed its implications for future spaceborne missions [Degnan, 2008a]. The airborne lidar operates with 100 beams from a single 22 kHz laser transmitter resulting in a maximum 2.2 Megapixel per second rate, which produces high resolution and contiguous images of the underlying terrain. Two space applications were discussed. One was the 16 beam Cross Track Channel (CTC) Lidar system proposed for NASA's ICESat-II mission. The nominal system requires 4 W of 532 nm output power (25 microjoules per pulse per channel x 10 kHz laser repetition rate x 16 channels). At this repetition rate, the terrain is interrogated every 70 cm in the alongtrack direction and every 140 m in the crosstrack direction within a total 2.1 km swath in order to provide ice scientists with much needed slope information in both axes. The second space application studied was NASA's Jupiter Icy Moons Orbiter (JIMO) mission. It was demonstrated analytically that a 100 beam scanning lidar, similar to the current airborne system, could map all three of Jupiter's moons – Ganymede, Callisto, and Europa – within a few months. The relatively low solar background at the outer planets makes them especially attractive targets for photon-counting lidars.

German researchers reported on a Laser Altimeter Simulator, which was developed in support of ESA's BepiColombo mission to Mercury [Heiner et al, 2008]. The history of US spaceborne laser altimetry missions and the science goals for the Mercury Laser Altimeter (MLA) enroute to Mercury and the Lunar Observer Laser Altimeter (LOLA) on LRO were reviewed [Smith and Zuber, 2008b].

References

- Artyukh, Yu., V. Bespalko, E. Boole, and V. Vedin, “Advances of High Precision Riga Event Timers”, Proc. 16th International Workshop on Laser Ranging, Poznan, Poland, 2008.
- Blazej, J. and I. Prohazka, “New achievements in the simulator of photon counting planetary altimeter”, *Ibid.*, 2008.
- Boole, E., and V. Vedin, “Potentialities of common-used TDC chips for high speed event timer design”, *Ibid.*, 2008.
- Burmistrov, V., V. Gloov, N. Parkhomenko, M. Sadovnikov, V. Shargorodsky, and V. Vasiliev, “State of the SLR in Russia”, *Ibid.*, 2008.
- Chen, C., C. Fan, Z. Li, and Y. Zhao, “Development of electronic circuit in high frequency SLR based on FPGA”, *Ibid.*, 2008.
- Degnan, J., “Simulating Interplanetary Transponder and Laser Communications Experiments via Dual Station Ranging to SLR Satellites”, Proc. 15th International Workshop on Laser Ranging, Canberra, Australia, 2006.
- Degnan, J., “Globally contiguous, high resolution, topographic mapping of planets and moons via photon counting”, Proceedings 16th International Workshop on Laser Ranging, Poznan, Poland, 2008a.
- Degnan, J. “Impact of receiver deadtime on photon counting SLR and altimetry during daylight operations”, *Ibid.*, 2008b.
- Degnan, J., J. McGarry, T. Zagwodzki, and T. Varghese, “Transmitter point-ahead using dual Risley prisms: theory and experiment”, *Ibid.*, 2008.
- Dunn, P., C. Clarke, and M. Torrence, “NGSLR performance in high and low energy option”, *Ibid.*, 2008.
- Fan, C., X. Dong, X. Han, and Y. Zhou, “Development of any frequency fire rate SLR control system”, *Ibid.*, 2008.
- Gibbs, P., G. Appleby, D. Benham, C. Potter, R. Sherwood, T. Shoobridge, V. Smith, and M. Wilkinson, “Herstmonceux – towards kHz ranging and multi-technique status”, *Ibid.*, 2008.
- Gurtner, W. E. Pop, and J. Utzinger, “The new 100 Hz laser system in Zimmerwald: Concept, Installation, and first experiences”, *Ibid.*, 2008.
- Hidalgo, I., A. Mozo, P. Navarro, R. Piriz, and D. Navarro-Reyes, “Use of SLR observations to improve Galileo GIOVE-B orbit and clock determination”, *Ibid.*, 2008.
- Heiner, M., U. Schreiber, and U. Hugentobler, “BepiColombo Laser Altimeter Simulator”, *Ibid.*, 2008.
- Huber, H., M. Schmidt, and S. Zoppel, “Advances of multi-kHz repetition rate picoseconds laser system for satellite laser ranging”, *Ibid.*, 2008.
- Iqbal, F., F. Koidl, and G. Kirchner, “Medium resolution event timer and range gate generator in Graz FPGA card”, *Ibid.*, 2008.
- Kirchner, G., F. Koidl, and D. Kucharski, “Graz kHz SLR lidar: first results”, *Ibid.*, 2008a.
- Kirchner, G., D. Kucharski, and F. Koidl, “Millimeter accuracy from centimeter targets”, *Ibid.*, 2008b.
- Kodet, J., and I. Prochazka, “Compact event timing and laser fire control device for one way laser ranging”, *Ibid.*, 2008.
- Mallama, A., J. McGarry, T. Zagwodzki, and J. Cheek, “Pre-launch testing of NGSLR ranging to LRO”, *Ibid.*, 2008.
- McGarry, T. Zagwodzki, T. Varghese, J. Degnan, D. Patterson, J. Cheek, C. Clarke, A. Mann, P. Dunn, R. Rickleffs, and A. Mallama, “NGSLR: sharing eye-safe kHz SLR with transponder ranging”, *Ibid.*, 2008.
- Moore, C., “Automation – recent progress at Mt. Stromlo SLR station”, *Ibid.*, 2008.
- Murphy, T., J. Degnan, W. Farr, W. Folkner, A. Girerd, H. Hemmati, K. Nordtvedt, R. Reasenberg, S. Turyshev, and J. Williams, “Mars laser ranging: science and design”, *Ibid.*, 2008a.
- Murphy, T., E. Adelberger, J. Battat, C. Hoyle, R. McMillan, E. Michelson, C. Stubbs, and H. Swanson, “APOLLO: one-millimeter lunar laser ranging”, *Ibid.*, 2008b.
- Nodop, D., J. Limpert, R. Hohmuth, W. Richter, M. Guina, and A. Tunnermann, “High-pulse-energy passively Q-switched quasi-monolithic microchip lasers operating in the sub-100-ps pulse regime”, *Optics Letters*, 32, pp.2115-2117 (2007).

- Otsubo, T., P. Gibbs, and G. Appleby, “KHz single photon ranging : a precise tool to retrieve optical response of satellites”, Proc. 16th International Workshop on Laser Ranging, Poznan, Poland, 2008.
- Prochazka, I., and J. Blazej, “Photon counting detectors for future laser time transfer missions”, *Ibid.*, 2008.
- Prochazka, I., and P. Panek, “Progress in sub-picosecond timing system development”, *Ibid.*, 2008.
- Samain, E., A. Abchiche, D. Albanese, N. Geyskens, G. Buchholtz, A. Drean, J. Dufour, J. Eysseric, P. Exertier, F. Pierron, M. Pierron, G. Lagarde, J. Paris, JM Torre, and H. Viot, “MeO: the new French lunar laser ranging station”, *Ibid.*, 2008a.
- Samain, E., Ph. Guillemot, P. Exertier, D. Albanese, P. Berio, O. Laurain, F. Para, J. Paris, JM Torre, H. Viot, P. Vrancken, I. Petitbon, and S. Leon, “Time Transfer by Laser Link –T2L2: first data”, *Ibid.*, 2008b.
- Schreiber, U., M. Heiner, B. Holzapfel, A. Neidhardt, P. Lauber, K. Haufe, N. Brandl, J. Oberst, and H. Michaelis, “Laser altimetry and transponder ground-based simulation experiment”, *Ibid.*, 2008.
- Smith, D. and M. Zuber, “Planetary laser ranging and altimetry missions and studies at NASA/GSFC and MIT”, *Ibid.*, 2008a.
- Smith, D. and Zuber, “Planetary laser altimetry: past and present”, *Ibid.*, 2008b.
- Wiant, J., R. Ricklefs, and P. Shelus, “LRO operations at the MLRS”, *Ibid.*, 2008.
- Wilkinson, M., “High speed Pockels cell shutter and the Herstmonceux MCP-PMT detector”,
- Yang, F., B. Wu, Z. Zhang, and T. Guo, “Upgrading plan of the Chinese SLR network”, *Ibid.*, 2008a.
- Yang, F., P. Huang, Z. Zhang, W. Chen, H. Zhang, Y. Wang, W. Meng, J. Wang, G. Zou, Y. Liao, I. Prochazka, Y. Zhao, C. Fan, and X. Han, “Preliminary results of the Laser Time Transfer (LTT) experiment”, *Ibid.*, 2008b.
- Zhang, Z., F. Yang, J. Chen, H. Zhang, Z. Wu, S. Qin, and P. Lu, “The experiment of kHz laser ranging with nanosecond pulses at Shanghai SLR”, *Ibid.*, 2008a.
- Zhang, Z., F. Yang, H. Zhang, Z. Wu, J. Chen, and Y. Artyukh, “Applications of Riga event timer at Shanghai SLR”, *Ibid.*, 2008b.

SECTION 7

ANALYSIS ACTIVITIES

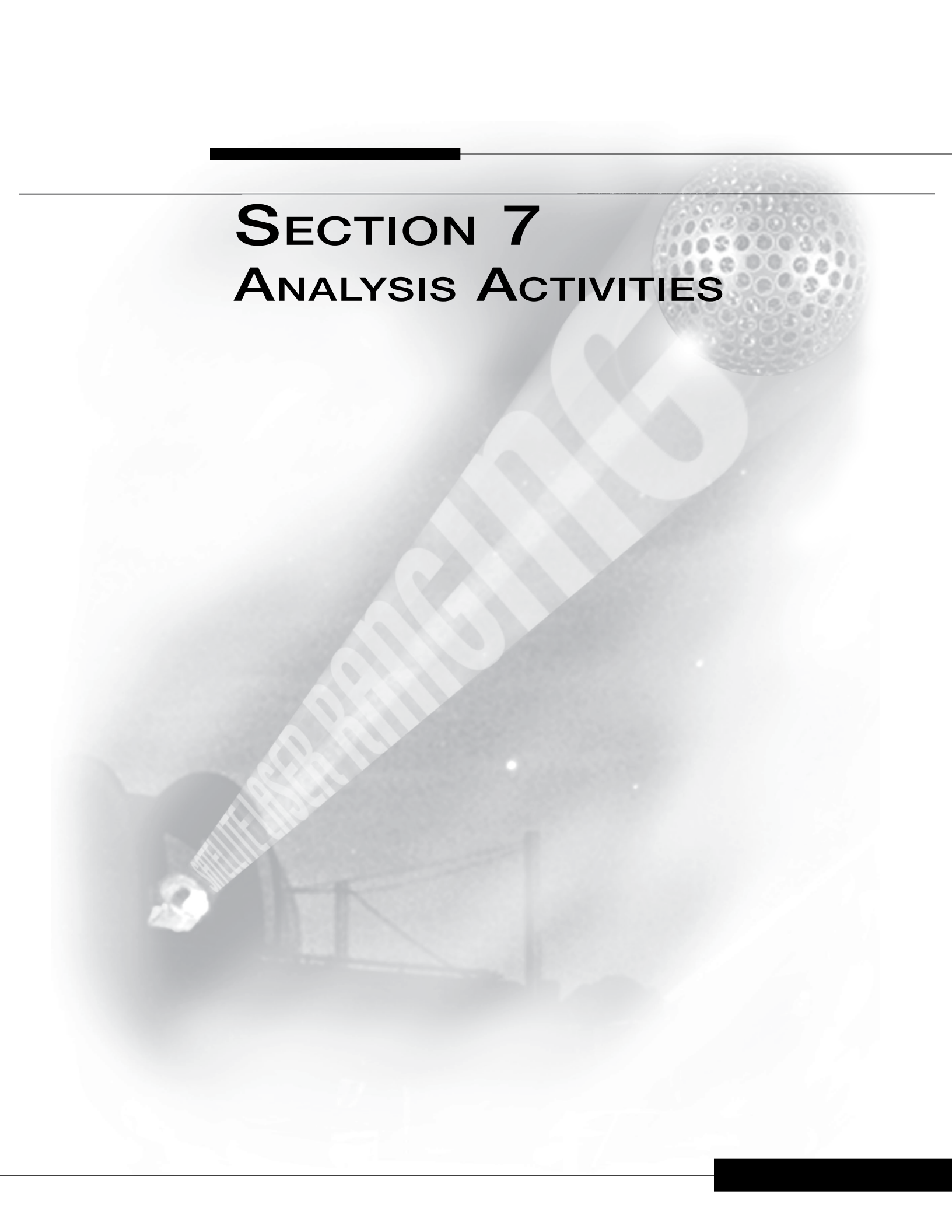

SECTION 7

ANALYSIS ACTIVITIES

Erricos C. Pavlis/JCET, Vincenza Luceri/e-GEOS S.p.A., Centro di Geodesia Spaziale

Introduction

The ILRS is an official Technique Service in the International Earth Rotation and Reference Frame Service (IERS). To fully exploit the unique aspects of the SLR observations, the ILRS Analysis Working Group (AWG) addresses various issues of SLR products, such as quality control, the estimated parameter group, the satellite data to be used, and format definition/use, optimization, and (the development of) an official combination product on the basis of the individual AC contributions. Additional products being considered are evaluated through a number of so-called pilot projects, with several initiated during the past few years, some of them successfully completed and others still ongoing. This contribution to the ILRS 2007-2008 Report presents an update on the status and the results of these efforts. General information on AWG activities, membership and more detailed information on the pilot projects can be found on the relevant ILRS webpages (http://ilrs.gsfc.nasa.gov/working_groups/awg/index.html).

Activities in 2007 and 2008

An important instrument for contacts and discussions among SLR/LLR analysts proves to be the AWG workshops. During the period covered by this ILRS report, five such workshops were organized: the seventeenth AWG meeting was held on April 14, 2007, during the spring EGU meeting in Vienna, Austria, the eighteenth on July 10, 2007, during the IUGG meeting in Perugia, Italy, the nineteenth on September 24, during the Fall ILRS Workshop in Grasse, France, the twentieth meeting was held on April 12, 2008, during the spring EGU meeting in Vienna Austria, and the twenty-first meeting on October 12, 2008, during the 16th International Workshop on Laser Ranging in Poznan, Poland. AWG meetings are planned to take place on dates close to major geophysical meetings (EGU) or other (ILRS) venues, in order both to maximize AWG members' attendance and also encourage interaction with other scientists. In addition to these, the AWG participated with presentations and contributions to several position papers in the Unified Analysis Workshop of the Global Geodetic Observing System (GGOS), in December 2007, in Monterey, CA.

A main element of the AWG activities is the development of a unique, best-possible (in terms of quality) analysis product that can be used by the widest possible science community, e.g., station positions and EOP. An official solution for station coordinates and daily EOPs is generated by the Analysis Centers (AC) and Combination Centers (CC) on a weekly basis, and submitted to the IERS as an official ILRS contribution. These weekly results depend on high-quality laser range observations to LAGEOS-1, LAGEOS-2 and to the two Etalon satellites, and the ILRS network is encouraged to support this valuable work, ideally by tracking these satellites day and night, seven days a week. Two different products are distributed each week: a loose constrained estimation of coordinates and EOP and an EOP solution, derived from the previous product, fully constrained to an ITRF. The development of these products goes back to the very first days of the ILRS AWG. The currently operational products and the adopted analysis scheme were agreed upon by the AWG and have run continuously in an operational mode since 2003.

At this moment, eight different ACs support this activity and routinely provide this product: ASI, BKG, DGFI, GA, GFZ, GRGS, JCET, and NSGF. ILRS has also adopted two official CCs, the primary hosted by ASI and the backup at DGFI. These two CCs are responsible for combining the input solutions, and the delivery of the quality-checked and combined ILRS product to the IERS. In preparing the weekly combination of the individual solutions, these

combination centers follow a strict timeline and have to make sure that the products are of the highest possible quality. Official weekly ILRS products from the two combination centers are available in SINEX format each Wednesday at the CDDIS and EDC. All ACs are encouraged to improve the quality of their contributions further. It is noteworthy that a number of other institutes (ESA/ESOC, MCC, and NCL) are also in the process of being certified as official ACs in order to eventually contribute to the combination solutions.

During the period covered by this ILRS report, the procedures and analysis models have been scrutinized and documented thoroughly (in order to avoid artificial differences and inconsistencies between results). A major effort of the AWG was to determine a very complete and accurate set of station biases and corrections based on the reports of the stations and the analysis of long-term solutions that decorrelate the biases from the station height estimates. This effort led to a rather complete set of biases and corrections that were adopted and used by all ACs and will be published on the ILRS web pages for use by all SLR data users in the future, in order to ensure the best and most consistent results for any application. For ease of use, the compilation is put in a SINEX-like format that is machine-readable and allows the automatic use of the information in any analysis environment.

The AWG has also faced one problem of the latest reference frame ITRF2005. The input ILRS time series for ITRF2005 only covered the years from 1993 to 2005 and its shortness had two main effects in ITRF2005: the lack of the older SLR stations and poor estimates for those stations which stopped observing in the early 1990's. To overcome the problem, a new TRF was generated: SLRF2005. The terrestrial reference frame was obtained by combining ITRF2000, ITRF2005 rescaled, and a global SLR solution with data from 1993 to 2007 to add the new sites. SLRF2005 is a temporary reference frame until a new complete frame will be available. Currently, SLRF2005 is the ILRS reference frame.

The results of the combination process are used as input for a number of products computed by others, e.g., the International Terrestrial Reference Frame (ITRF) 2008 solution, developed under the coordination of the IERS, and the IERS Combination Pilot Project (CPP) towards a unified GGOS product. As a result of the weekly combination process, the ILRS also maintains a time series of the similarity transformation parameters of the weekly product with respect to the current ITRF – SLRF2005 during this reporting period. For SLR, the weekly geometric offsets of the origin from the conventionally defined ITRF origin provide a measure of the motion of the geocenter due to mass redistribution in the Earth system. Similarly, the time series of the scale differences with respect to the current ITRF provide a measure of the stability of the SLR-defined TRF.

To improve the usefulness of the time series of combination solutions and the ancillary products, and thus improve its prospects for future utilization (reliability of resulting velocities, results on historical SLR stations, etc.), the ILRS AWG decided to extend the period covered by these solutions. In a first step, this was done by a full re-analysis of the LAGEOS-1 and -2 and Etalon data (where available) for the interval 1993–2008, with the same procedures and conventions as those applied in the operational product. Following that, the contributing ACs worked on a re-analysis of the LAGEOS data over the historical period 1983-1993; since the observations from this time frame are of an inferior quality and a single satellite (prior to the launch of LAGEOS-2), these analyses require a modified parameterization approach (e.g., biweekly arcs, consideration of additional bias adjustment, three-day EOP, etc.). Initial (preliminary) results were submitted to IERS for ITRF2008, in late 2008, which upon their preliminary analysis will serve as the basis for the final submission (later in 2009), taking into account the feedback from the ITRS. Figure 7-1 shows the three -month running average of the origin and scale components for the “historical” data period (1984-1992). This period is based on LAGEOS data alone and ground systems with much less accurate data than the present network, which are the reasons behind the large and often systematic behavior during this period.

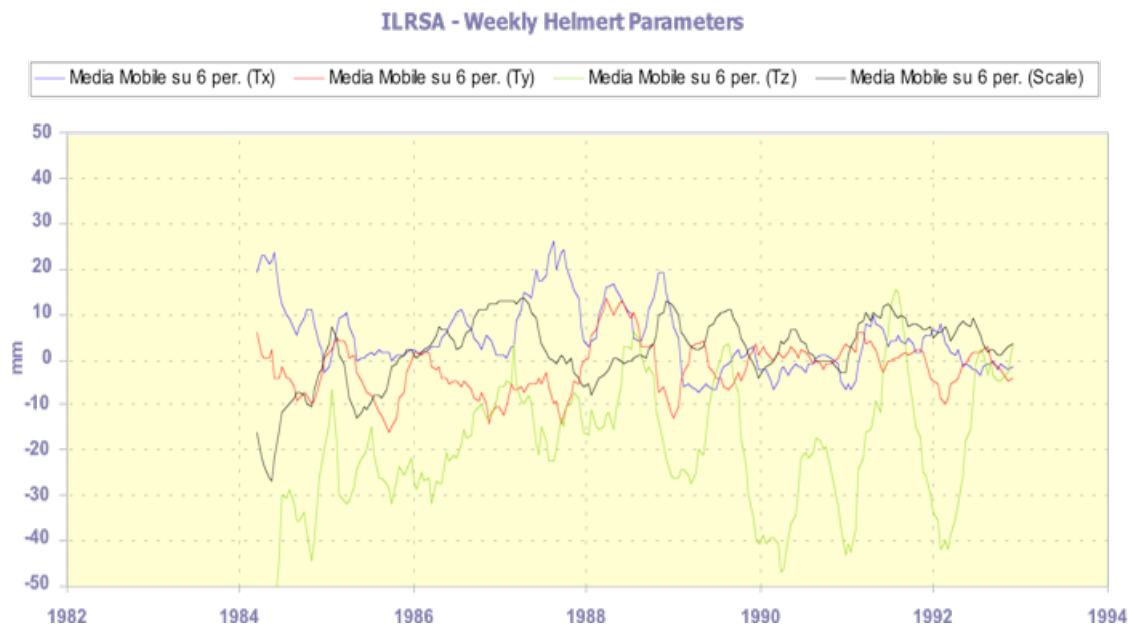

Figure 7-1. Time-series of X, Y, and Z offsets and scale factor averages (3-month boxcar smoothing) of the ILRS-A official combination origin with respect to the reference TRF (SLRF2005) origin (proxy for “geocenter” variations) and scale as observed by SLR (1984.0 – 1993.0).

The corresponding components for the period 1993 to 2009 are shown in Figure 7-2. It is evident that the contribution of data from LAGEOS-2 during this period, and the Etalon-1 and -2 after 2002, are helping to considerably stabilize the series and the improved data quality results in the trend-free series, demonstrating only seasonal signals of geophysical origin. The IERS/ITRS uses the SLR solutions to exclusively determine the origin of the new ITRF2008 solution. Unlike the previous ITRF2005 solution, the scale for the 2008 realization will be determined through some combination of the SLR and VLBI contributions, similar to the way that was traditionally done in the past.

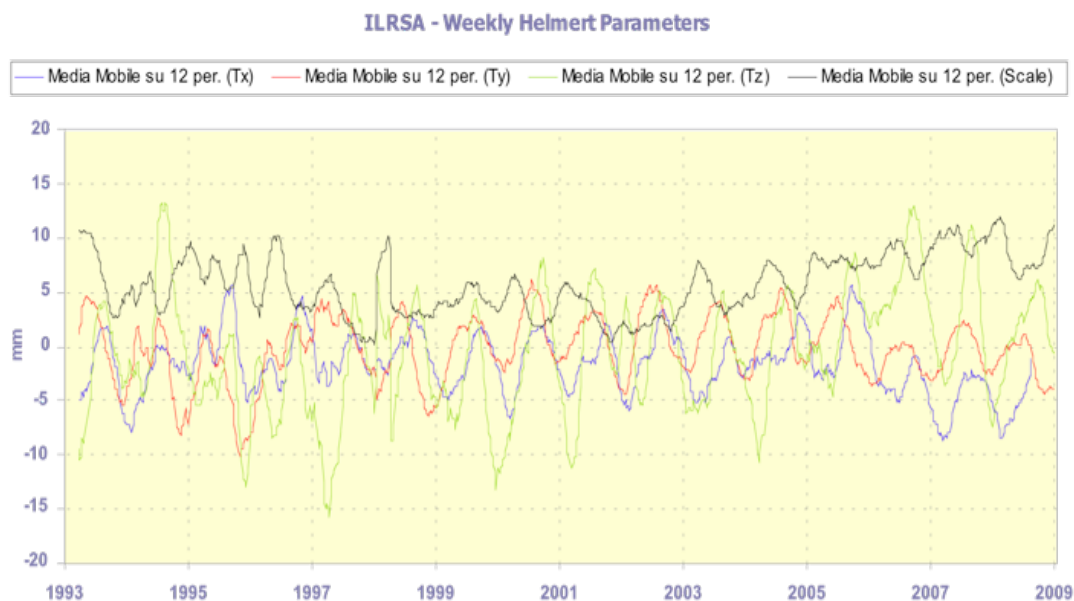

Figure 7-2. Time-series of X, Y, and Z offsets and scale factor averages (as in Figure 7-1) as observed by SLR (1993.0 – 2008.0).

The AWG is currently expanding its list of weekly products to fill a void in the area of routinely available precise orbits for the primary SLR targets, i.e., the two LAGEOS and two Etalon satellites. At present this is only a pilot project; however, it is expected that by 2009 these products will be delivered routinely on a weekly basis. In order to fulfill the need of NEOS for as “fresh” as possible EOP information, the ILRS AWG decided in late 2007 to develop a new “daily” product, based on a seven-day arc sliding by one day each day. The results of this analysis are available to NEOS within two days from the last observation in the analysis, and efforts are underway to further decrease the latency period. During 2007, three ACs (ASI, JCET, and NSGF) contributed to the pilot project for this daily product, by the end of 2008 two more ACs (BKG and GFZ) joined the group and it is expected that in the future more ACs will contribute. NEOS will evaluate the new product and the ILRS will decide whether to evolve this pilot project into an official product (replacing the weekly one), or to discontinue it.

Another ongoing activity of the AWG is the improvement of the quality control (QC) process in various semi real-time analysis results with a unique analysis report, which is made available to all customers (stations, satellite managers, ILRS). This effort reduced inconsistencies among the various previous reports. The results of the QC process are combined in a single report, which is available weekly at: http://aiuas3.unibe.ch/ftp/slr/summary_report.txt. A major improvement in the consistency of these results was the adoption the single set of high quality station coordinates given by SLRF2005. This TRF was used as the a priori one for the re-analysis that generated the ILRS contribution to ITRF2008.

SECTION 8

MODELING

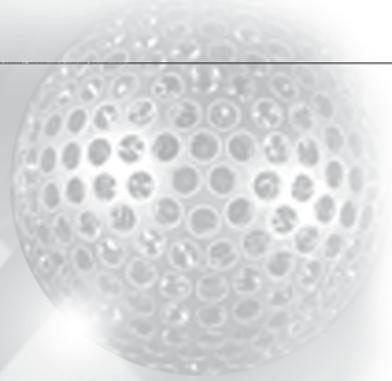

SECTION 8

MODELING

Vincenza Luceri/e-GEOS S.p.A., Centro di Geodesia Spaziale and Erricos C. Pavlis/JCET

Improved Measurement Bias Modeling

The first reanalysis of the ILRS data for ITRF2005 indicated that the new models we use in the reduction process are now sensitive enough to allow us to fit the LAGEOS data with an RMS of a few millimeters, consistently below one centimeter. These improved fits revealed the existence of station biases that were previously undetected and made it clear that in order to benefit from the improvement of the background models, we would have to address seriously the measurement bias issue.

Lists of data editing and corrections (october 2007; REVISED 090118)

Those lists have been proposed by ASI at the AWG meeting in Grasse (September 2007) and accepted by the ILRS/AWG for the generation of the ILRS official products.

LIST OF DATA TO BE DELETED

Site No.	Wav	Core NonCore in VS0	Solve ?	Model ?	bias in sol VS0	SOLUTION PROPOSAL	Source
1863	G	NC	NO	NO	--	data before 1994.0	
1873	G	NC	NO	NO	--	data before 1995.0	
1884	G	NC	NO	NO	1993.0 ->	data before August 1994	
1893	G	NC	NO	NO	--	data before 1998.0	CDDIS
7112	G	NC	NO	NO	--	data before 1985.0	
7123	G	NC	NO	YES	--	data from 25 to 30 August, 1988 (3 m bias) data on May 12, 1993 (> 500 meter bias)	
7236	G	NC	NO	NO	--	data after 1998.0 (a few acquisitions)	
7237	G	NC	NO	NO	--	data before 1996.0	
7249	G	NC	NO	NO	--	data before 1999.0	
7355	G	NC	NO	NO	--	use only data in 2003	
7510	G	NC	NO	NO	--	data from 920623 to 920930 to be deleted	CDDIS
7585	G	NC	NO	NO	--	data from 920623 to 920930 to be deleted	CDDIS
7810	B	C	NO	YES	--	data from Dec 18, 1996 to Dec 29, 1997	
7811	G	NC	NO	YES	1993.0 -1994.0	data before 1993:202	CDDIS
7820	G	NC	NO	NO	--	data before 2000:291	CDDIS
7824	G	NC	NO	NO	--	data before 1996	
7831	G	NC	NO	YES	--	data before 1984	
7832	G	C	NO	NO	--	data before 1998	
7835	G	NC	NO	YES	--	data before Oct 1988	
7837	G	C	NO	NO	--	data before 1990	
7841	G	NC	NO	NO	--	data before Feb 19, 2004	

LIST OF SITES WITH BIAS ESTIMATION

Site No.	Wav	Core NonCore in VS0	Solve ?	Model ?	bias in sol VS0	SOLUTION PROPOSAL
1864	G	NC	YES	NO	1993.0 ->	bias to be estimated over all the period
1868	G	NC	YES	NO	1993.0 ->	bias to be estimated over all the period
1953	G	NC	YES	NO	--	bias to be estimated over all the period
7548	G	NC	YES	NO	--	bias to be estimated over all the period
7308	G	NC	YES	NO	--	bias to be estimated over all the period
7548	G	NC	YES	NO	--	bias to be estimated over all the period
7810	I	C	YES	NO	--	bias to be estimated over all the period
7845	G	NC	YES	NO	--	bias to be estimated over all the period (bad for EOP referencing)

LIST OF SITES WITH RANGE BIAS APPLICATION

The range correction should be subtracted from the data and is one-way

Site No.	Wav	Core NonCore in VS0	Solve?	Model?	bias in sol VS0	SOLUTION PROPOSAL			Bias Source
						Start Date	End Date	Correction	
1873	G	C	NO	YES	---	1995	2000	-270 mm	Analysis
7080	G	C	NO	YES	---	Jan 1, 1988	Dec 15, 1989	-40 mm	Analysis
						April 4, 1990	Jan 31, 1993	25 mm	CDDIS
								Correction to be added to the pressure values	
						March 6, 1995	Jan 26, 1996	2.1 mB	CDDIS
						Jan 26, 1996	April 25, 1996	10.3 mB	CDDIS
						April 25, 1996	May 8, 1996	9.7 mB	CDDIS
7109	G	NC	NO	YES	---	Jan 9, 1997	Jan 18, 1997	164.9 mm	CDDIS
7110	G	C	NO	YES	---	Jan 01, 1984	May 15, 1984	30 mm	Analysis
						Oct 27, 1987	Jan 25, 1988	30 mm	Analysis
						Aug 27, 1996	Oct 3, 1996	163.6 mm	CDDIS
7122	G	NC	NO	YES	---	May 1984	Mar 15, 1987	30 mm	Analysis
7123	G	NC	NO	YES	---	July 14, 1987	Oct 9, 1987	-30 mm	CDDIS
7210	G	NC	NO	YES	1993-2005	1983.0	Sep 12, 1987	25 mm	Analysis
						Sep 12, 1987	Jan 21, 1994	-37 mm	Analysis
						Jan 21, 1994	2000	-11 mm	Analysis
7237	G	NC	NO	YES	---	1996.0	1998.0	20 mm	Analysis
						1998.0	June 24, 2002	-20 mm	Analysis
7512	G	NC	NO	YES	---	Mar 1992	May 1992	-30 mm	Analysis
7517	G	NC	NO	YES	---	June 1992	August 1992	-94 mm	Analysis
7525	G	NC	NO	YES	---	March 1992	June 1992	11 mm	CDDIS
7544	G	NC	NO	YES	---	Sept 1992	Dec 1992	-85 mm	Analysis
7545	G	NC	NO	YES	---	Oct 1993	Mar 1994	15 mm	Analysis
7580	G	NC	NO	YES	---	Nov 1992	Jan 1993	68 mm	Analysis
7587	G	NC	NO	YES	---	Aug 1992	Oct 1992	30 mm	Analysis
7810	B	C	NO	YES	---	May 24, 1988	Sept 30, 1989	50 mm	Analysis
						Jan 1998	May 29, 2002	-26 mm	Analysis
						May 29, 2002	Dec 28, 2004	-20 mm	Analysis
						Dec 28, 2004	Feb 6, 2006	-26 mm	Analysis
7811	G	NC	NO	YES	1993-1994	Jul 20, 1993	May 19, 1998	-50 mm	Analysis
						May 19, 1998	Mar 28, 2003	-35 mm	Analysis
7831	G	NC	NO	YES	---	1987	June 1990	+85 microsec	CDDIS
7834	G	NC	NO	YES	---	Mar 11, 1985	Jul 18, 1986	-30 mm	Analysis
7835	G	NC	NO	YES	1993-1998	Sep, 1991	Sept 9, 1997	25 mm	Analysis
7836	G	NC	NO	YES	---	Jan 1, 1994	Oct 12, 1994	18.45 mm	CDDIS
7839	G	C	NO	YES	93.0 to 09/96	1983	Sept 28, 1996	-22 mm	Analysis
7840*	G	G	NO	YES	---	Jan-1984	Dec-1984	30 mm	Analysis
						Sep-15, 1988	Dec-1992	Bias drift	Analysis
						Oct-1, 1994	Feb-1, 2002	-2.5 mm	Appleby
						Feb-1, 2002	Feb-10, 2007	5.5 mm	Appleby
8834	G	C	NO	YES	1993-1997	1990	Nov 1, 1992	-35 mm	CDDIS
						Nov 1, 1992	April 15, 1996	40 mm	Analysis
						April 15, 1996	Oct 13, 2000	5 mm	Analysis

* Consult new (separate) table of corrections for 7840

Figure 8-1. The three lists of data handling to account for known or suspected measurement biases for the entire ILRS network.

The first step in this direction was to scrutinize and document thoroughly all events at each site that could potentially lead to a measurement bias. The sources for this information are the station reports, SLRmail-reported events, and personal communications with station engineers. The result of these initial inquiries was a number of lists (Figure 8-1) that identified stations and time periods over which their data were to be either deleted from any analysis, corrected with bias estimates provided by the local engineering team, or flagged to have mandatory biases estimated during any analysis.

Determining a complete and accurate set of station biases and corrections based on the above was augmented and verified with the analysis of long-term solutions that decorrelate the biases from the station height estimates. Figure 8-2 shows an example of one site before and after the application of biases identified by this process. It is evident that without accounting for these biases, the otherwise high quality data from the station at Zimmerwald, Switzerland, would be wasted, and the contribution of the station in the overall development of the product significantly diminished.

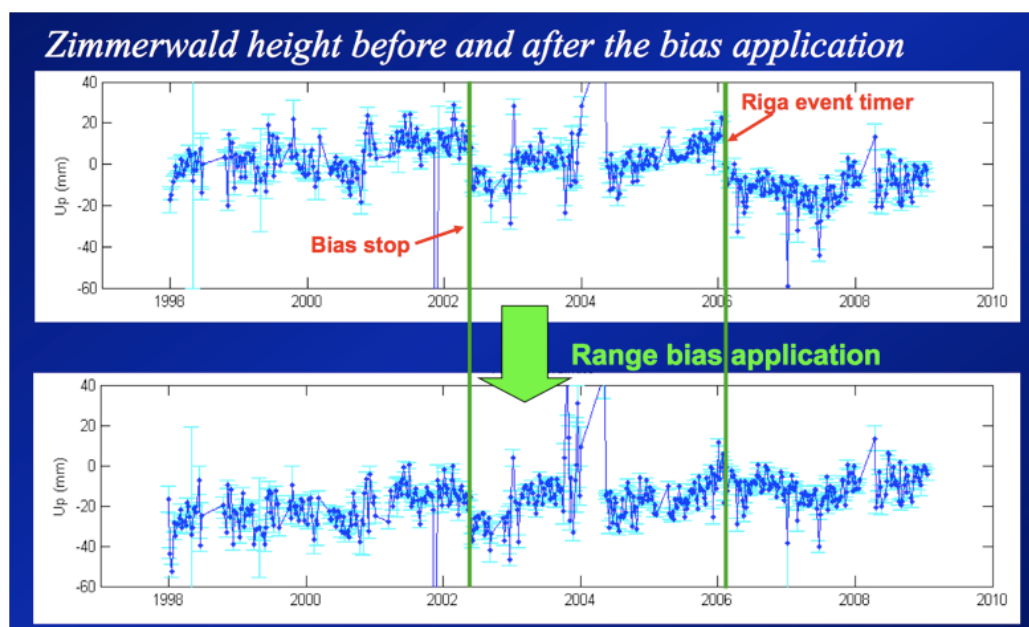

Figure 8-2. Biweekly height variation at Zimmerwald, Switzerland with respect to a long-term height estimate. Solid lines indicate known events that could cause biases in the data. The top panel shows the time series before the application of the biases, the bottom one after correcting for these biases, indicating a much improved, flatter evolution of the station height.

The bias validation and documentation effort led to a rather complete set of biases and corrections that after several iterations and tests were adopted to be used by all ACs. The process was complicated by the fact that part of the data corrections reported in these lists were due to Stanford counter non-linearity, for several sites that used these counters. A major effort at Herstmonceux attempted to estimate these corrections using the experience, data, and hardware that were still available at the site, and once validated, to extend this process to other sites of the network where the counters were no longer available [Appleby et al., 2007]. Unfortunately, the process of post-calibrating these systems proved ineffective, delivering rather arbitrary and at times even opposite sign estimates, so the effort was abandoned and it was decided instead to estimate biases from the data itself, using the long-term solutions.

The list of all (accepted) reported and estimated biases was published on the ILRS webpages, to be used by all ACs in the reanalysis for the ITRF2008. A parallel effort compiled all of this information in a SINEX-like format that is machine-readable and allows the automatic use of the information in any analysis environment. SLR data users in the future will be directed to access this file when analyzing data in order to ensure the best and most consistent results for any application. The file will be kept up to date and extended as new information becomes available. At the moment the final version of this file is pending release, awaiting the release of the final list of possible biases in the data, from the final combination of the ILRS submission to ITRS with those from other techniques.

The process of improved bias handling was presented at various conferences [Bianco et al., 2008], [Luceri et al., 2009] and workshops [Appleby, 2007], [Luceri, 2007], [Appleby et al., 2008], [Ries, 2007] in order to give users a clear view of the underlying mechanism used to decide the biases and to assure the users of ILRS products (e.g., ITRS) that this process used reliable and valid information that would result in far more stable products in the future.

Cannonball Spacecraft Center-of-Mass Offset Modeling

Graham Appleby/NERC, Toshimichi Otsubo/Hitotsubatshi University (HIT-U) and Erricos C. Pavlis/JCET

SLR measurements are in principle unbiased and provide an absolute measure of the distance between the ground system reference point and the Effective Reflecting Plane (ERP) of the Laser Reflector Array (LRA) on the spacecraft. This, however, requires that we have predetermined, through theoretical studies and very accurate measurements, the geometry of that ERP with respect to the center-of-mass (CoM) of the spacecraft. The problem is obviously more complicated for active satellites with moving appendages, variable attitude orientation, thrusters that consume fuel, etc. For the purely geodetic, cannonball shape passive satellites the situation is by far simpler although not entirely so. This has been identified as one of the limiting sources of error in breaking the millimeter barrier in the accuracy of ILRS products, so it has attracted a lot of attention lately, primarily from the dedicated Working Group (Signal Processing WG), but also from a newly formed ILRS “Task Force” that involved more than SPWG engineers.

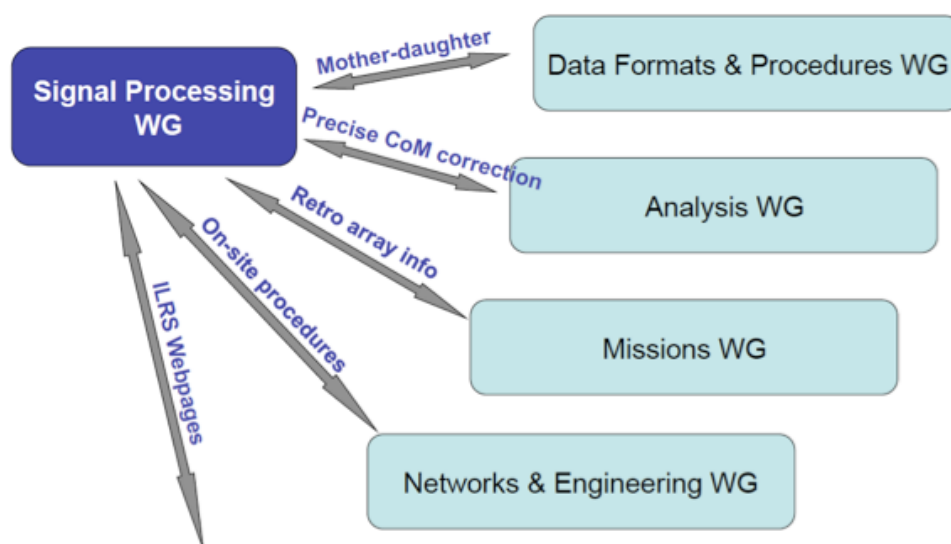

Figure 8-3. The interaction between the Signal Processing WG and other ILRS bodies.

The primary concern of that group was to prepare the best possible CoM tables for the ILRS network, considering the variety of ground systems and operating modes of the stations. The first priority for tackling this was for the LAGEOS spacecraft since they are the basis for the official ILRS products, followed next by the Etalon satellites. The fact that this group exchanges information with many of the ILRS components further underscores the importance of these measurements (Figure 8-3).

Table 8-1. Ground-system dependence for LAGEOS' CoM correction and adopted standard.

Stn pad ID	Name	Pulse length (ps)	Detector	Regime (single, few, multi)	Editing Level ($\times\sigma$)	Calib. St. error (mm)	LAGEOS St. error (mm)	LAGEOS CoM range (mm)	LAGEOS CoM ADOPTED (mm)
1873	Simeiz	350	PMT	No CNTL	2.0	60	70	248-244	246
1884	Riga	130	PMT	CNTLD s->m	2.0	10	15	252-248	250
7080	McDonald	200	MCP	CNTLD s->m	3.0	8.5	13	250-248	249
7090	Yaragadee	200	MCP	CNTLD f->m	3.0	4.5	10	250-248	249
7105	Greenbelt	200	MCP	CNTLD f->m	3.0	5	10	250-248	249
7110	Mon. Peak	200	MCP	CNTLD f->m	3.0	5	10	250-248	249
7124	Tahiti	200	MCP	CNTLD f->m	3.0	6	10	250-248	249
7237	Changchung	200	CSPAD	CNTLD s->m	2.5	10	15	250-245	248
7249	Beijing	200	CSPAD	No CNTL, m	2.5	8	15	255-247	251
7355	Urumqui	30	CSPAD	No CNTL	2.5	15	30	255-247	251
7405	Conception	200	CSPAD	CNTLD s	2.5	15	20	246-245	246
7501	Harteb.	200	PMT	CNTLD f->m	3.0	5	10	250-244	247
7806	Metsahovi	50	PMT	?	2.5	15	17	254-248	251
7810	Zimmerwald	300	CSPAD	CNTLD s->f	2.5	20	23	246-244	245
7811	Borowiec	40	PMT	No CNTL f	2.5	16	23	256-250	253
7824	San Fernando	100	CSPAD	No CNTL s->m	2.5	30	25	252-246	249
7825	Stromlo	10	CSPAD	CNTLD s->m	2.5	4	10	257-247	252
7832	Riyadh	100	CSPAD	CNTLD s->m	2.5	10	15	252-246	249
7835	Grasse	50	CSPAD	CNTLD s->m	2.5	6	15	255-246	250
7836	Potsdam	35	PMT	CNTLD s->m	2.5	10	20	256-252	254
7838	Simosato	100	MCP	CNTLD s->m	3.0	20	40	252-248	250
7839	Graz	35	CSPAD	No CNTL m	2.2	3	9	255-250	252
7839	Graz kHz	10	CSPAD	No CNTL s->f	2.2	3	9	255-250?	252
7840	Herstmonceux	100	CSPAD	CNTLD s	3.0	6	15	246-244	245
7840	Hx kHz	10	CSPAD	CNTLD s	-1.5,+2.5	3	9	245	245
7841	Potsdam 3	50	PMT	CNTLD s->f	2.5	10	18	254-248	251
7941	Matera	40	MCP	CNTLD m	3.0	1	5	252-248	250
8834	Wetzell	80	MCP	No CNTL f->m	2.5	10	20	252-248	250

One of the complications of determining an accurate CoM correction for each target satellite derives from the fact that this correction depends not only on the spacecraft and LRA geometry, but also to a large extent on the type of ranging and detection system that is used at the tracking ground station. This dependence has been known for a long time now, but it has been applied explicitly by the analysts only in the case of the single-photon system at Herstmonceux, UK, while a single CoM offset was used for all other sites and satellites. Over the past years it became obvious that unless this correction was applied with the utmost accuracy possible, SLR would suffer from increased jitter in its scale definition and poor fits to the tracking data. With scale being one of the most important SLR contributions to ITRF, the improved handling of this correction is now one with the highest priority.

During the past two years the SPWG has generated a table that provides the most accurate values for the CoM correction for LAGEOS-1 and -2, for all active stations of the ILRS network and for all of their operating modes (Table 8-1). Although this has been published already on the ILRS webpages:

http://ilrs.gsfc.nasa.gov/stations/site_info/data_correction/nsf_iCoM_LAGEOScorrections.html

it was decided that the official ILRS products would adopt these new CoM corrections after the contribution to ITRF2008 is finalized, during the next reanalysis phase. At the same time, using similar procedures, a second table with the appropriate CoM for the two Etalon spacecraft was developed and finalized (Table 8-2), which will also become the standard at the same time as the previous one for LAGEOS. However, it should be understood that in general it is not possible to determine CoM corrections accurate at the mm-level for these large spherical satellites. This fact has been recognized in what is considered a realistic range of CoM values for each tracking station and for each satellite and given in these tables along with the adopted single value that should be used by analysts. It should also be pointed out that although in most cases the discrepancy from an overall mean value is only a few millimeters and well below most stations' noise levels, the fact that this is a systematic error affecting directly the SLR-implied scale of the network, makes it extremely important for the development of the ITRF. It is therefore the first "improvement" to be adopted immediately next when the Analysis WG enters a new phase of data reanalysis.

Both tables are “live” documents, being kept up-to-date as stations change operating modes or as new stations join the network. It is thus advised that users should query the ILRS pages often in order to be sure that they use the latest version. It is highly likely that before these tables become effective in the day-to-day analyses, a machine-readable version will be placed online so that analysts can link directly to it on the fly.

Table 8-2. Ground-system dependence for Etalon CoM correction and adopted standard.

Stn pad ID	Name	Pulse length (ps)	Detector	Regime (single, few, multi)	Editing Level ($\times\sigma$)	Calib. St. error (mm)	ETALON CoM range (mm)	ETALON CoM ADOPTED (mm)
1873	Simeiz	350	PMT	No CNTL	2.0	60	593-603	598
1879	Altay	150	PMT	No CNTL	2.5	20	600-610	605
1884	Riga	130	PMT	CNTLD s->m	2.0	10	602-612	607
7080	McDonald	200	MCP	CNTLD s->m	3.0	8.5	598-608	603
7090	Yaragadee	200	MCP	CNTLD f->m	3.0	4.5	598-608	603
7105	Greenbelt	200	MCP	CNTLD f->m	3.0	5	598-608	603
7110	Mon. Peak	200	MCP	CNTLD f->m	3.0	5	598-608	603
7119	Haleakala	200	MCP	CNTLD f->m	3	4.5	598-608	603
7124	Tahiti	200	MCP	CNTLD f->m	3.0	6	598-608	603
7237	Changchung	200	CSPAD	CNTLD s->m	2.5	10	570-580	575
7249	Beijing	200	CSPAD	No CNTL, m	2.5	8	570-580	575
7355	Urumqui	30	CSPAD	No CNTL	2.5	15	576-586	581
7358	Tanegashima	50	MCP	No CNTL	3	1.3	602-612	607
7405	Conception	200	CSPAD	CNTLD s	2.5	15	573-577	575
7406	San Juan	40	CSPAD	No CNTL	2.5	8	576-586	581
7501	Hartab.	200	PMT	CNTLD f->m	3.0	5	598-608	603
7806	Metsahovi	50	PMT	?	2.5	15	602-612	607
7810	Zimmerwald	300	CSPAD	CNTLD s->f	2.5	20	570-574	572
7811	Borowiec	40	PMT	No CNTL f	2.5	16	602-612	607
7824	San Fernando	100	CSPAD	No CNTL s->m	2.5	30	573-583	578
7825	Stromlo	10	CSPAD	CNTLD s->m	2.5	4	576-586	581
7832	Riyadh	100	CSPAD	CNTLD s->m	2.5	10	573-583	578
7835	Grasse	50	CSPAD	CNTLD s->m	2.5	6	604-613	609
7836	Potsdam	35	PMT	CNTLD s->m	2.5	10	604-613	609
7838	Simosato	100	MCP	CNTLD s->m	3.0	20	602-612	607
7839	Graz	35	CSPAD	No CNTL m	2.2	3	569-579	574
7839	Graz kHz	10	CSPAD	No CNTL s->f	2.2	3	571-577	574
7840	Herstmonceux	100	CSPAD	CNTLD s	3.0	6	563-567	565
7840	Hx kHz	10	CSPAD	CNTLD s	-1.5,+2.5	3	563-567	565
7841	Potsdam 3	50	PMT	CNTLD s->f	2.5	10	606-612	609
7941	Matera	40	MCP	CNTLD m	3.0	1	607-613	610
8834	Wetzell	80	MCP	No CNTL f->m	2.5	10	603-613	608

Advanced Refraction Modeling

Erricos C. Pavlis/JCET and Glynn Hulley/JPL

SLR is an optical technique and as such it is not affected greatly by atmospheric refraction as other space geodetic techniques operating in the microwave region of the spectrum. Nevertheless, since we strive for mm-level accuracy, even the otherwise small effects of horizontal gradients in the lower atmosphere must be accounted for. One proven way to do this is to compute refraction corrections along the laser beam path directly from three-dimensional ray tracing (3D ART) through the meteorological fields that are now routinely available. This method was pioneered and tested with the analysis of two years of SLR data by Hulley and Pavlis [2007a, b, c, d]. The concept is described in the graphic and equations shown in Figure 8-4. As discussed in [ibid], the SLR data for 2004-2005 were corrected using refraction corrections obtained using the 3D ART approach, based on three different global fields: ECWMF, NCEP and the satellite observations from the AIRS instrument on board the Aqua NASA platform.

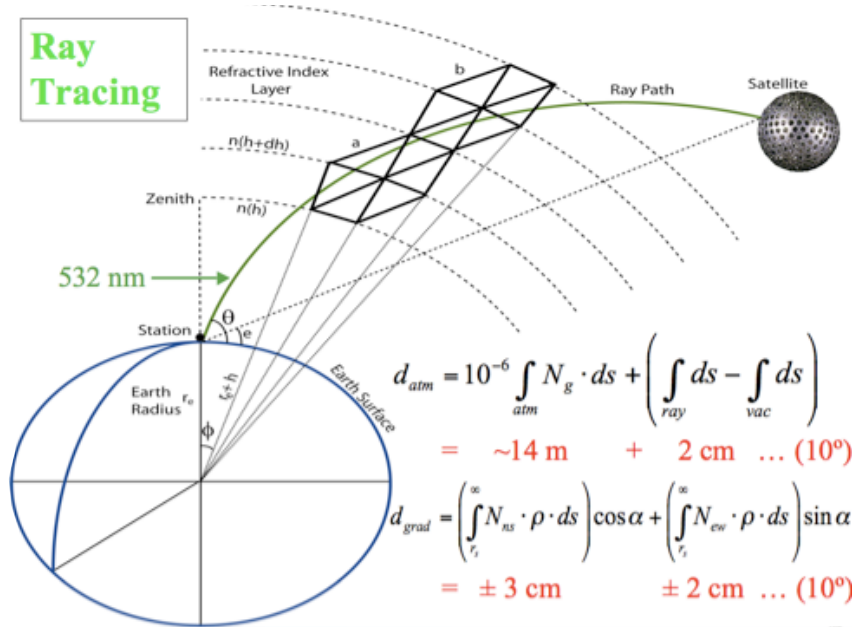

Figure 8-4. The three-dimensional ray tracing approach to computing the total atmospheric delay along the path of a SLR range observation.

The comparison of atmospheric gradient variations obtained from the three sources agreed in generally very well, however, it is quite apparent when one looks at the results shown in Figure 8-5 for the Herstmonceux site, that AIRS and ECMWF are in much better agreement than any other pair. After applying these corrections to the SLR data, the RMS residual fits improve considerably, indicating the importance of these corrections for future analyses. Statistics of these comparisons are shown in Table 8-3. From these results it is evident that 3D ART with AIRS-observed meteorological fields is the best approach, explaining almost 25% of the residual variance. An alternate approach where the isotropic delay is modeled through the analytical model of [Mendes and Pavlis, 2004] and the gradients are obtained from 3D ART is not as effective, explaining only 14% of the variance for the same data.

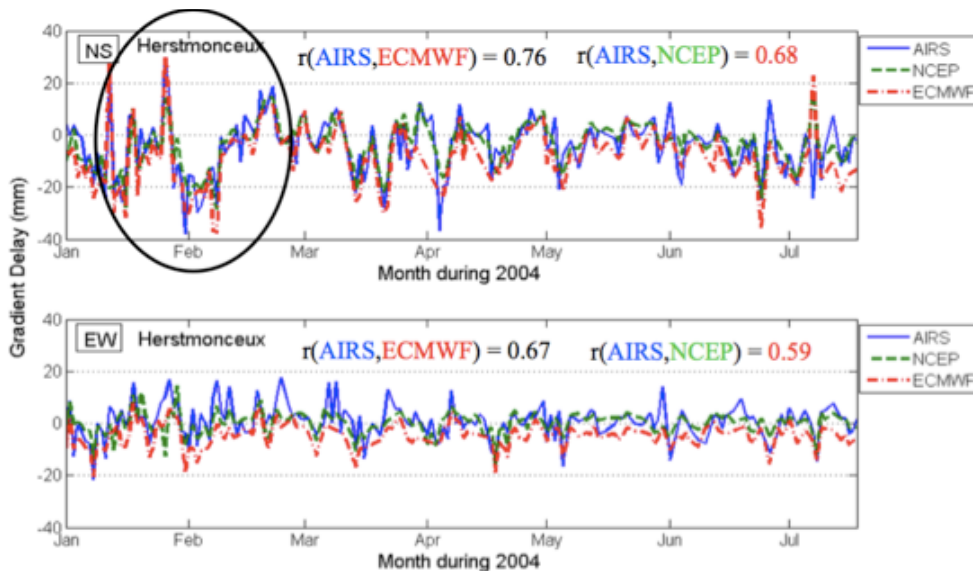

Figure 8-5. Atmospheric gradients at Herstmonceux during 2004, from three different source fields (AIRS, NCEP and ECMWF).

At this point there is no routine computation of refraction corrections in an operational way, so the above 3D ART approach will have to await until someone can commit to produce these corrections as part of a service to the ILRS. When available, their utilization in the data analysis process will be a rather trivial matter. The results of this investigation were presented at ILRS workshops, the AGU and published in refereed journals [Hulley and Pavlis, 2007a, b, c, d].

Table 8-3. Residual statistics of SLR data corrected with 3D ART atmospheric delays.

Method	Δ Bias (mm)	$\Delta\sigma$ (%)
AIRS		
RT _{grad}	0.3 ± 0.3	14.0
RT _{3D}	0.9 ± 1.1	24.8
ECMWF		
RT _{grad}	0.1 ± 0.5	10.8
RT _{3D}	0.6 ± 1.2	22.5

Atmospheric Loading Modeling

Erricos C. Pavlis, Magdalena Kuzmich-Cieslak, and Peter Hinkey/JCET

The effect of atmospheric circulation (mass redistribution) is currently not modeled during the reduction of SLR data for official ILRS products. This is because IERS requires that this effect be applied to products by all of the services simultaneously, to avoid a mixed result. During the GGOS Unified Analysis Workshop of 2007 (UAW 2007), each of the Technique Analysis Coordinators were tasked to perform some limited testing to determine the level of impact this new model will have on their products. In the case of ILRS the modeled effect applies to the orbit as well as the loading effect that modifies primarily the tracking sites' height. Using the meteorological global fields of ECMWF we can derive a correction to each station's position due to this loading effect. This has been provided as a service for a few years now [Petrov and Boy, 2004], and results are available for various operational and experimental fields from ECMWF (versions v0, v1 and v2), as well as from NCEP:

"v0": 1970/01 - 2002/08: ECMWF Reanalysis (ERA40), with a spatial resolution of 1.125 degrees

"v1": 2000/12 - 2006/12: ECMWF Operational, with a spatial resolution of about 0.350 degrees

"v2": 2005/10 –present: ECMWF Operational, with a spatial resolution of about 0.250 degrees

Because of the existence of these multiple versions of the ECMWF fields, we chose to analyze SLR data in 2001 and 2006, so that we can test the maximum possible set of these fields. The results obtained from these tests were compared to those obtained without atmospheric modeling, and the statistics of their differences are summarized in Table 8-4.

Table 8-4. Statistics of RMS differences (in mm) for the 2001 & 2006 LAGEOS SLR data reductions with atmospheric loading modeling from various ECMWF releases.

Test Case	Points (weeks)	Mean	Median	RMS	Std Deviation
Δ RMS v0-NO*	52	3.4	2.7	4.45	2.87
Δ RMS v1-NO	104	2.9	2.1	4.31	3.16
Δ RMS v2-NO	52	2.7	1.7	4.09	3.08
Δ RMS v1-v0	52	0.4	0.0	0.92	0.82
Δ RMS v2-v1	52	1.7	1.4	2.58	1.96

*NO indicates no atmospheric loading modeling

The top three rows of Table 8-4 show that any of the three versions of ECMWF fields, when used to derive loading at the tracking sites improves the results with an average reduction in the overall RMS of fit of the order of 3 mm in the mean (or 2 mm median difference), and a similar magnitude of variation about the mean over the tested weeks.

The last two rows compare the three variations of the ECMWF released fields, as “seen” through the orbit filter controlled by SLR tracking data. Evidently, the difference between v0 and v1 is insignificant given the magnitude of the mean and the corresponding RMS. Apparently, going from 1°.125 resolution down to 0°.350 is not making a huge difference. On the other hand, the difference between v1 and v2 is much larger, although that one does not seem statistically significant either when one considers the scatter associated with it. Additionally, the comparison of v1 and v2 is over 2006, when the data that are used to form the ECMWF fields are quite different from those used in 2001 (when we compared the v1 to v0), dominated by global fields obtained from satellite missions. Irrespective of which ECMWF product one uses, it is evident that there is a significant change (improvement) in the fits to SLR data and if one compares this change to the present day state-of-the-art results, the conclusion is that we can no longer afford to not model such effects if our goal is to achieve millimeter or better geodesy.

It is expected that following the completion of the reanalysis effort for the ITRF2008 development, the ILRS AWG will conduct internal tests to verify the consistent application of atmospheric effects and include it as part of the standard model for the next reanalysis. The results from these tests were presented at various conferences [Pavlis, 2007], [Boy et al., 2008], ILRS workshops [Pavlis et al., 2008] and a dedicated EGU session [Boy et al., 2008].

References

- Appleby, G.M., T. Otsubo, P. Gibbs, (2007), Further Improvements in Understanding Subtle Systematic Effects in Laser Ranging Observations (solicited), *Geophys. Res. Abs.*, Vol 9, EGU, 2007.
- Appleby, G., M. Wilkinson, V. Luceri, P. Gibbs, V. Smith, (2008), Attempts to separate apparent observational range bias from true geodetic signals, 16th Int. Laser Workshop, Poznan, Poland, Oct. 13-17, 2008.
- Appleby, G., (2007), Engineering-assessed SLR Range biases, GGOS Unified Analysis Workshop, Monterey, CA 93940, USA, 05 - 07 December 2007.
- Bianco, G., V. Luceri, C. Sciarretta, (2008) Stability and consistency of the SLR contribution to the ITRF (solicited), EGU2008-A-09217, EGU 2008, Vienna, Austria, 13 – 18 April 2008.
- Boy, J.-P., Gégout, P., Hinderer, J., Luthcke, S. B., Pavlis, E. C., Rowlands, D. D., (2008) Atmospheric loading effects on time-variable gravity and surface displacements (solicited), EGU2008-A-06309, EGU 2008, Vienna, Austria, 13 – 18 April 2008.
- Boy, J-P., P. Gegout, J. Hinderer, F. Lemoine, S. Luthcke, E. C. Pavlis, D. Rowlands, (2008), “Atmospheric, oceanic and hydrological loading effects on time-variable gravity and surface displacements”, *New Challenges in Earth’s Dynamics*, ETS2008, 1-5 September, 2008, Jena, Germany.
- Hulley, G. and Pavlis, E. C., (2007a), Refraction modeling in SLR by ray tracing through meteorological data, EGU2007-A-04957, EGU 2007, Vienna, Austria, 15 – 20 April 2007.
- Hulley, G. and Pavlis, E. C., (2007b), AIRS-enabled refraction modeling in SLR using ray tracing, IUGG XXIV General Assembly, Perugia, Italy, 2 – 11 July 2007.
- Hulley, G., and E. C. Pavlis, (2007c), Improvement of Current Refraction Modeling in Satellite Laser Ranging (SLR) by Ray Tracing through Meteorological Data, 15th Int. Laser Workshop, John Luck (ed.), pp. 345-350, Geosciences Australia, Canberra.
- Hulley, G. C. and E. C. Pavlis, (2007d), A ray-tracing technique for improving Satellite Laser Ranging atmospheric delay corrections, including the effects of horizontal refractivity gradients, *J. Geophys. Res.*, 112, B06417, doi:10.1029/2006JB004834.
- Luceri, V., (2007), Analysis-assessed SLR Range biases, GGOS Unified Analysis Workshop, Monterey, CA 93940, USA, 05 - 07 December 2007.
- Luceri, V., C. Sciarretta, G. Bianco, and G. Appleby (2009) The measurement bias effects in the ILRS product for ITRF, EGU2009-8265, EGU 2009, Vienna, Austria, 19 – 24 April 2009.
- Mendes, V. and E. C. Pavlis, (2004), “High-Accuracy Zenith Delay Prediction at Optical Wavelengths”, *Geophys. Res. Lett.*, 31, L14602, doi:10.1029/2004GL020308.
- Pavlis, E. C., (2007), Towards an improved ILRS TRF contribution, BIPM - Pavillon de Breteuil, S vres, France, September 20-21, 2007.
- Pavlis, E. C., Magdalena Kuzmicz-Cieslak and P. M. Hinkey, (2008), “Improved Modeling Approaches Towards

the mm SLR”, 16th Int. Laser Workshop, Poznan, Poland, Oct. 13-17, 2008.

Petrov, L., and J.-P. Boy, (2004), Study of the atmospheric pressure loading signal in VLBI observations, *J. Geophys. Res.*, 109, B03405, doi:10.1029/2003JB002500.

Ries, J., (2007), Identification of Systematics by Co-location on Satellites, GGOS Unified Analysis Workshop, Monterey, CA 93940, USA, 05 - 07 December 2007.

SECTION 9

SCIENCE REPORT

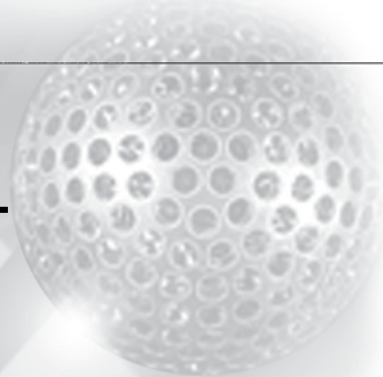

FRASER PUBLISHING



11 12 13 14 15 16 17 18 19 20 21 22 23 24 25 26 27 28 29 30 31 32 33 34 35 36 37 38 39 40 41 42 43 44 45 46 47 48 49 50 51 52 53 54 55 56 57 58 59 60 61 62 63 64 65 66 67 68 69 70 71 72 73 74 75 76 77 78 79 80 81 82 83 84 85 86 87 88 89 90 91 92 93 94 95 96 97 98 99 100

SECTION 9

SCIENCE REPORT

Steve Klosko/SGT

Introduction

Satellite Laser Ranging began tracking near-Earth satellites over 40 years ago with stations in Maryland and North Carolina tracking the Beacon Explorer satellites. From the beginning, the range accuracy delivered by laser systems far surpassed the absolute accuracy delivered by other tracking technologies, a fact that has remained unchanged to the present. With a focus on continually improving the range accuracy that SLR systems can deliver, and improving the analysis techniques that employ SLR, laser tracking has continued to be an important contributor to precision orbit determination and the generations of science products of a geophysical nature.

The ILRS provides a forum for laser practitioners to discuss the science investigations they are pursuing and to better understand the technology advancements that underpin their efforts.

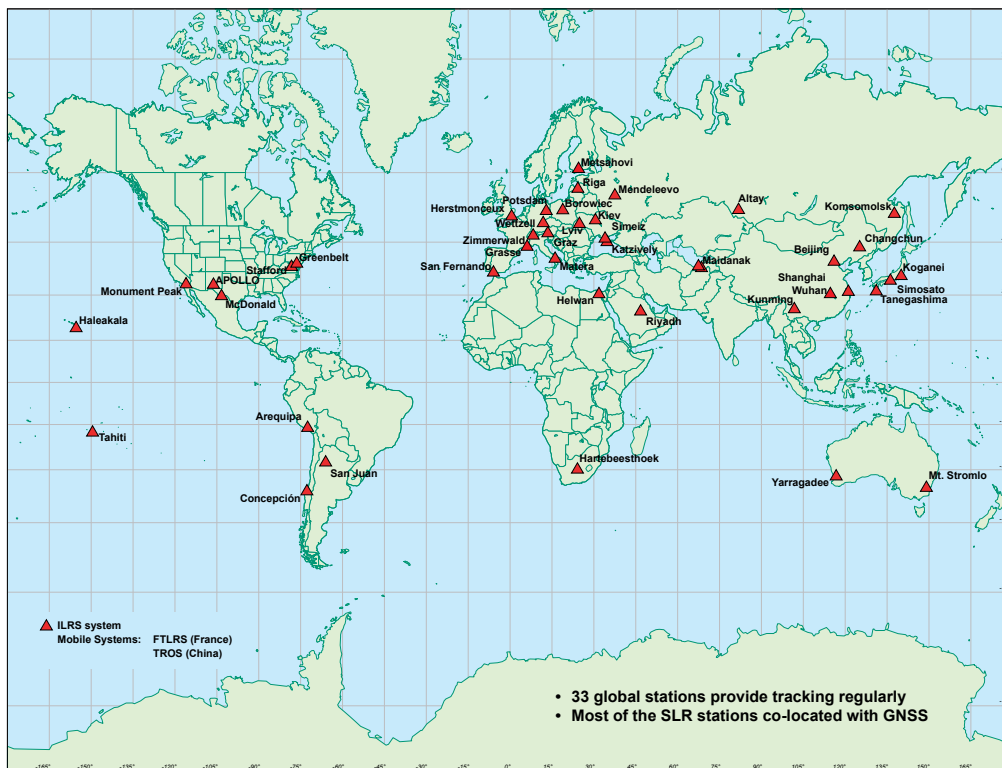

Figure 9-1. The current ILRS network

Under the auspices of the ILRS, today's laser network finds more than thirty active stations (Figure 9-1) with an ever-increasing number of targets to support. For example, the ILRS Board recently approved tracking of Cryosat-2 and RadioAstron which brings to a total of 44 the number of current and future satellites tracked or to be tracked by the laser network.

The new missions that will be supported in 2009 are shown in Figure 9-2 below. Advances in technology and in data processing methodologies have improved the accuracy of the SLR science products. Important technical advances that contribute to improvements in the science delivered include: new kilohertz systems, systems which operate at dual wavelengths, improved orbiting reflector targets, and improved orbit force and measurement modeling. This summary will address these developments and describe the current state of the SLR science and mission support that is being delivered.



Figure 9-2. Proposed missions supported by the ILRS for 2009.

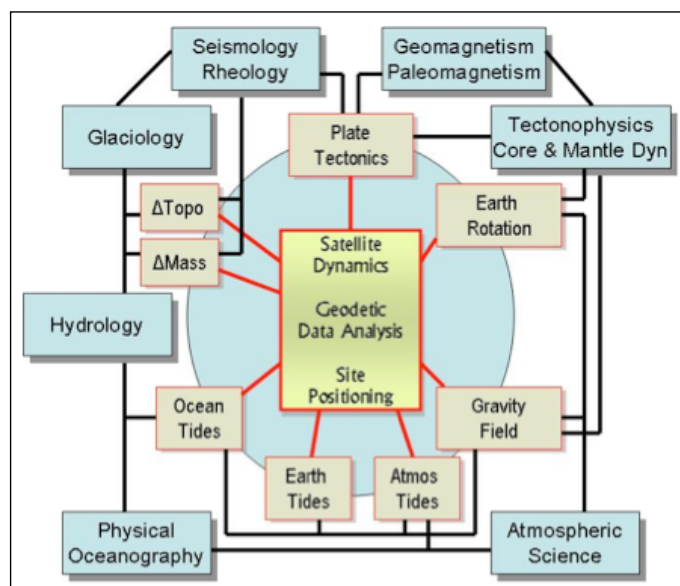

Figure 9-3. SLR data, techniques and products provide a means to measure the manifestation of key geophysical processes.

Figure 9-3 left gives an overview of the role SLR plays within multidisciplinary and interdependent investigations ongoing in the Earth Sciences. The center green box shows the basic analyses that use SLR data. These analyses yield significant products (connected to this center box with red lines), which provide important evidence and constraints in a wide range of science applications and disciplines through direct observation of the temporal behavior of geodynamical processes. The fundamental products delivered by SLR are: highly accurate orbits and improved understanding of the forces at work; accurate station locations and their 3-dimensional movement within a well understood terrestrial frame; Earth center-of-mass and the absolute scale of the terrestrial frame; and the longest continuous history of Earth orientation parameters determined by space geodetic techniques. SLR science investigations have contributed to studying important physical processes related to the state and sustainability of the Earth’s environment including the sources and magnitude of

mass flux, in defining a stable mm-level reference frame, and in developing an integrated and interdependent understanding of the Earth's system in four dimensions at increasingly detailed scales. SLR has provided precision orbits for the constellation of orbiting laser targets and an independent calibration of precise orbit positioning provided by other tracking systems. By being a dynamic technique, SLR is able to improve the fundamental force modeling needed to produce cm-level orbit accuracy. These force models are science products in their own right.

SLR provides important and in many cases key independent validation capabilities within the GRACE, Envisat, Jason, OSTM and ICESat missions. Herein, SLR complements the set of measurements acquired by these missions. At the same time, dedicated SLR satellite missions like LAGEOS-1 and -2 continue to provide unique long wavelength gravity and decadal time histories of site motions to help establish the geophysical context for many of the phenomena being observed by missions like GRACE. This is especially evident when modeling the Glacial Isostatic Adjustment (GIA) processes dominant over high latitude regions needed to understand contemporary ice sheet mass balance and its contribution to sea level rise. Overall, in each of these missions, and in our attempts to optimally exploit their data, SLR plays an important role.

Below is an overview of current SLR science activities.

Lunar Laser Ranging

Lunar laser ranging has also continued to advance in recent years. The new APOLLO station located at the Apache Point Observatory, New Mexico, has significantly advanced LLR capabilities. With its 3.5 meter telescope and the excellent viewing conditions in the New Mexico desert, the APOLLO station produces multiple photons returned with each laser pulse, yielding mm-level range precision to the Moon. This is a significant gain over earlier deployed LLR capable systems. The data acquired by LLR significantly improves our ability to model and confirm relativistic effects such as the relativistic geodetic precession; and the evolution of the Earth-Moon system.

Gravity Field Determination

The tracking taken on the constellation of SLR satellites continues to improve the recovered time changes in the longest wavelength components of the Earth's gravity field. These SLR results are being used for the calibration/validation of the monthly gravity fields produced from the GRACE intersatellite tracking data, and likely those from GOCE (although at this writing, preliminary GOCE results are awaiting release). In many investigations, the $C(2,0)$ time history produced by SLR is incorporated with or replaces the GRACE-determined time series for this term. One of the most interesting developments in the last 15 years has been our ability to measure the Earth's gravity field to sufficient accuracy and temporal resolution to observe subtle changes in its longest wavelength features (e.g., Cox and Chao, 2002; Cheng, et al,). SLR analyses were the first to observed temporal variations in the gravity field at a variety of tidal and non-tidal frequencies and this was the basis and forerunner of the very successful GRACE mission. SLR remains a key component in validating the changes in the long wavelength gravity field observed from GRACE.

From these observations of mass redistribution on and within the Earth, significant improvements have been achieved in our understanding of Earth's upper mantle viscosity, the tidal response at different frequencies, and the tidal braking in the Earth/Moon system. The latter of which, given its change in lunar mean motion, is exquisitely confirmed directly through the use of Lunar Laser Ranging.

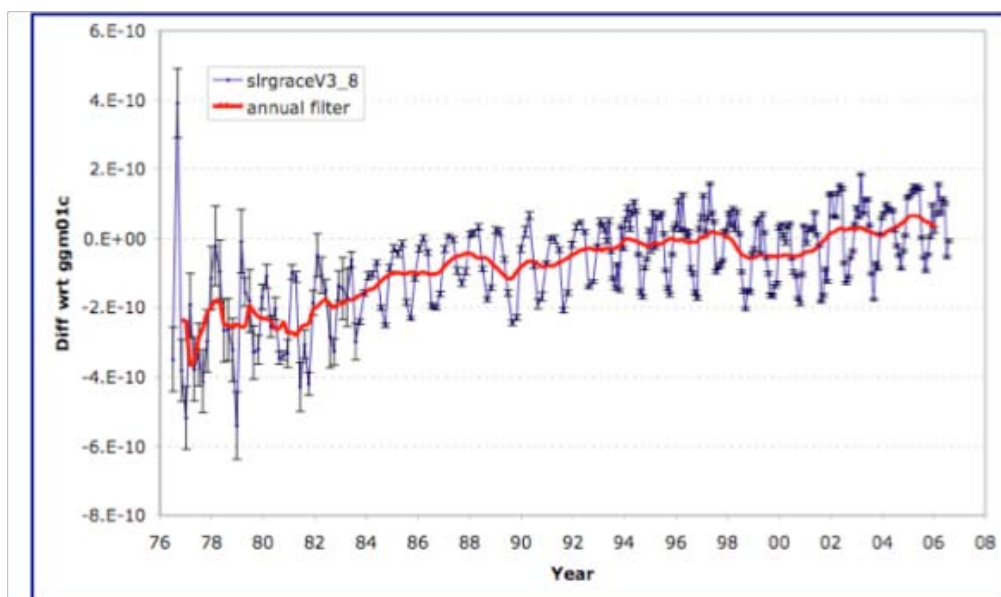

Figure 9-4. Changes in the $C(2,0)$ harmonic over the past three decades obtained from SLR tracking of primarily the LAGEOS satellites (update from Cox and Chao, 2002).

While the GRACE satellites continue to perform nominally and are expected to successfully operate to 2013 and beyond, current plans show an interruption in the time-varying gravity time series awaiting the launch of a GRACE-Follow-On Mission. If this is unchanged, SLR will be a critical resources for the bridging of this time series, at least at its longest wavelengths, and considerable attention will need to be paid in combining SLR with other available tracking data types (e.g., DORIS, GPS, radar and laser altimetry) to deliver the highest quality and best spatially and temporally resolved gravity fields during this period.

Reference Frame

Space geodesy is required to resolve geodynamical signals at mm to sub-mm levels of accuracy on a wide variety of time and spatial scales. To accomplish this goal, an International Terrestrial Reference Frame (ITRF) and the motion of the Earth within both the Inertial and Celestial Systems are required with high temporal resolution and with comparable accuracy. The implementation of the terrestrial reference frame (including its origin and scale) is now being derived by combining results from station coordinate solutions independently being solved and in combination using four space geodetic technologies – SLR, VLBI, GPS and DORIS. Under the auspices of the International Association of Geodesy, the Global Geodetic Observing System (GGOS) is an effort that is underway to produce and maintain an ITRF that has an accuracy for site positioning of 1 mm and 0.1 mm/yr for site motions. GGOS is coordinating with a worldwide network of organizations to provide the geodetic infrastructure necessary for detailed monitoring of the Earth system and its global changes at this accuracy level.

The most recent combination of these technologies produced the ITRF2005, which yielded some controversial results (Altamimi, et al., 2007). The scale difference between SLR (ILRS) and VLBI (IVS) was observed for the period of 2002 onward and has been resolved at least in part as an error in the VLBI processing. The SLR community developed a modified ITRF for laser analyses, but at some level this defeats the purpose of having a multi-technology and unified reference frame (Luceri and Bianco, 2007). A significant amount of work is underway to deliver refined and improved SLR contributions to the ITRF2008. These SLR contributions will significantly benefit from force modeling improvements like those developed to support GRACE (e.g. atmospheric and hydrological mass flux) and products coming directly from GRACE like improved mean and time varying comprehensive gravity fields (e.g., Förste et al., 2008; Luthcke et al., 2006; Lemoine et al., 2007).

Another important role for SLR within the ITRF is its applications within the Global Navigation Satellite Systems (GNSS). The GNSS represents the current satellite navigation systems that are capable of providing autonomous geo-spatial positioning with global coverage. SLR is now supporting operations on 7 GNSS satellites (GPS 36; GLONASS 102, 109 and 115; GIOVE –A and – B; and Compass-M1). SLR is uniquely able to independently calibrate and verify the key orbit determination accuracies being achieved for these GNSS satellites and is a means to bridge and assess the interoperability and consistency across GNSS constellations. At the same time SLR is not required for use in routine/operational RF derived orbit and clock products but provides a key monitoring function (Urschl et al., 2007).

Fundamental Physics

As knowledge of the long wavelength gravity field has improved, especially with advances coming from the GRACE mission, further improvements are being made in the estimation of the Lense-Thirring effect, the dragging of inertial frames due to the Earth's angular momentum. SLR pursuits of this science goal will significantly increase with the coming launch of the LARES satellite (Ciufolini et al., 2008).

LARES, a satellite developed by ASI, the Italian space agency, is expected to launch during 2010. The satellite is a dense sphere, completely passive, and is covered with 92 cube corner retroreflectors. LARES will be inserted into a circular 1,400 kilometers at an inclination from 60 to 86 degrees. The main scientific objective of the LARES mission is the measurement of the Lense-Thirring effect, with an accuracy goal of about a few percent as well as providing measurements across the field of geodynamics and space geodesy (Ciufolini et al., 2009).

Satellite Laser Altimetry

Satellite Laser Altimetry is a rapidly advancing form of remote sensing which has yielded extremely interesting results in both Earth and planetary sciences applications. There is a high interest in the SLR community of these developments. Indeed, on the basis of the National Research Council's Decadal Survey, two of the four "Tier 1" missions will fly laser altimeters – ICESat II primarily for ice surface mapping, and DESDynI – for both natural hazard and biospheric/biomass applications.

For interplanetary applications, great strides are being made in our understanding of aspects of planetary geophysics with the successful laser altimeter experiments on Mars Global Surveyor and Near Earth Asteroid Rendezvous missions. Lunar Reconnaissance Orbiter LRO now yields a large data set for lunar studies and future manned landing site locations. Mercury MESSENGER, Dawn, and anticipated missions to the icy moons of Jupiter are all expected to add additional science insights to a wide range of planetary bodies. The LOLA data from LRO has already improved our knowledge of the Moon's surface topography (Smith et al., 2009).

Laser altimetry has also matured from LEO platforms. For example, ICESat has already delivered over 2.1 billion ranges and has produced the first ever direct mapping of the thickness of the Arctic ice sheets. These results have been complementary to the traditional measures of ice extent and have made significant contributions to our understanding of the degradation in ice sheets seen over the past three years (Schutz et al., 2005; Brenner et al., 2007).

SLR systems support the companion efforts using satellite radar altimetry to directly monitor the ocean's circulation and global rate of sea level rise. All state-of-the-art radar altimeter satellites (TOPEX/Poseidon, Jason-1, OSTM, Envisat) fly laser retroreflectors. SLR tracking to these satellites is used to support a wide variety of altimeter range calibration experiments and help to ensure consistent time series spanning these missions (Lemoine et al., 2010; Cerri et al., 2010; Beckley et al., 2007).

Lunar and Planetary Satellite Tracking

As a precursor to interplanetary laser communication applications, during the past few years GSFC demonstrated a one-way laser transmission from Earth to the Mars Global Surveyor satellite orbiting Mars. This range experiment was over a distance of over 80 million kilometers. This exceeded the successful experiment that involved Earth to the MESSENGER satellite transmission and increased the range distance by over a factor of three (Smith et al., 2006; Neumann et al., 2007; Degnan, 2008).

An additional activity is underway where the LRO is being tracked by Earth-based SLR systems. The objective of the LRO Laser Ranging (LR) system is to enable LRO to have high quality precision orbits to support the analysis of the laser altimeter experiment, LOLA, flown on the spacecraft. The LR makes one-way range measurements via laser pulse time-of-flight from Earth to LRO, and from these data, enables the position of the spacecraft to be determined at the sub-meter level with respect to Earth and the center of mass of the Moon (Zuber et al., 2009; McGarry et al., 2007).

Ranging occurs whenever LRO is visible in the line of sight from participating Earth ground tracking stations. The first two successful SLR passes between a terrestrial ground station and a spacecraft orbiting the Moon were obtained on July 1 and 2, 2009 between the NGSRL station at Greenbelt, Maryland, USA (shown in Figure 9-5), and the Lunar Reconnaissance Orbiter (LRO). The Lunar Ranging data to LRO are being analyzed and validated and the data flow and system operations for operational ranging to LRO are being tested. The LR system on LRO will supplement the S Band (radio) tracking system for purposes of precision orbit determination and gravity field improvement (Torrence, et al., 2009).

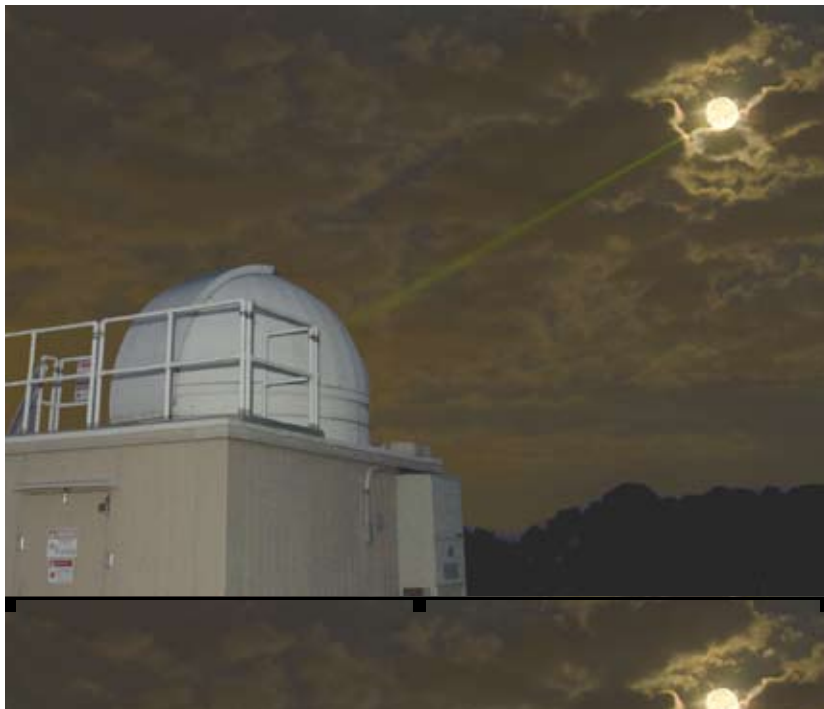

Figure 9-5. NGSRL ranging to LRO orbiting the Moon.

Summary

As for the future, the ongoing trend towards higher accuracy, larger data volumes and the need to support more missions is expected to continue. The SLR community needs to continue striving for an absolute single shot accuracy of one millimeter, a more automated and robust international network, and increased collaboration and contribution to many ongoing and future missions. The unprecedented richness of coincident observations from the international SLR network, offers significant opportunity to improve our understanding of the integrated Earth and planetary systems awaiting further exploration.

References

- Altamimi, Z., Collilieux, X., Legrand, J., et al. (2007), ITRF2005, A new release of the International Terrestrial Reference Frame based on time series of station positions and earth orientation parameters. *J. Geophys. Res.* 112(B9), B09401.
- Beckley, B.D., Lemoine, F.G., Luthcke S.B., et al. (2007), A reassessment of TOPEX and Jason-1 altimetry based on revised reference frame and orbits, *Geophys. Res. Lett.*, 34, L14608, 2007, DOI:10.1029/2007GL030002.
- Brenner, A.C., DiMarzio J.R., and Zwally, H.J. (2007), Precision and accuracy of satellite radar and laser altimeter data over the continental ice sheets, *IEEE Trans. on Geosci. Remote Sensing*, 45(2).
- Cerri, L., Mercier, F., Berthias, J.P., et al. (2010), Precision orbit determination standards for the Jason series of altimeter missions, *Marine Geodesy special issue on the Jason-1/Jason-2 mission calibration and tandem mission*, Manuscript in revision.
- Ciufolini, I., A. Paolozzi, E. Pavlis (2008), "Status of the LARES Experiment for Accurate Measurements of Earth Gravitomagnetism", 16th International Workshop On Laser Ranging, Poznan, Poland, Oct. 13-17, 2008.
- Ciufolini, I., Paolozzi, A., Pavlis, E.C., et al. (2009), Towards a one percent measurement of frame dragging by spin with satellite laser ranging to LAGEOS, LAGEOS-2 and LARES and GRACE gravity models, *Space Sci. Reviews*, 148(1-4), 71-104.
- Cox, C.M, and B.F. Chao (2002), Detection of a large-scale mass redistribution in the Earth system, *Science*, 297,831-833.
- Degnan, J. (2008), Laser transponders for high-accuracy interplanetary laser ranging and time transfer, *Lasers, Clocks and Drag-Free Control*, Astrophysics and Space Science Library, Vol. 349, Springer Verlag, Berlin.
- Förste, C., Schmidt, R., Stubenvoll, R., et al. (2008), The GeoForschungsZentrum Potsdam/Groupe de Recherche de Géodésie Spatiale satellite-only and combined gravity field models, EIGEN-GL04S1 and EIGEN-GL04C, *J. Geod.*, 82(6), pp. 331-346.
- Lemoine, J.M., Bruinsma S., Loyer S., et al. (2007), Temporal gravity fields inferred from GRACE data, *Adv. Space Res.*, 39,1620-1629.
- Lemoine, F.G., Zelensky N.P. Chinn, D.S., et al. (2010), Towards development of a consistent orbit series for TOPEX/Poseidon, Jason-1 and Jason-2, *Adv. Space Res.*, DORIS Special Issue, In review.

- Luceri, V., Bianco, G. (2007), The temporary ILRS reference frame: SLRF2005, International Laser Ranging Service Fall Meeting, 24-28 Sept., 2007, Grasse, France, URL: http://www.oca.eu/gemini/ecoles_colloq/colloques/ilrs2007/articles.php?lng=en&pg=98
- Luthcke, S.B., Rowlands, D.D., Lemoine, F.G., et al. (2006), Monthly spherical harmonic gravity field solutions determined from GRACE inter-satellite range-rate data alone, *Geophys. Res. Lett.*, 33(2), art. L02402, DOI:10.1029/2005G1024846.
- McGarry J., T. Zagwodzki, R. Ricklefs, et al. (2007), “An Update on Laser Ranging to LRO”, Fall 2007 ILRS Workshop, Grasse France, Sept. 25-28, 2007.
- Neumann, G., Cavanaugh, J., Coyle, B., McGarry, J., Smith, D., Sun, X. Zagwodzki, T., Zuber, M. (2006), Laser Ranging at Interplanetary Distances, 15th International Workshop on Laser Ranging, Canberra, Australia, Oct 15-20, 2006. URL: <http://cdis.gsfc.nasa.gov/lw15/>
- Schutz, B.E., Zwally H.J., Shuman, C.A., et al. (2005), Overview of the ICESAT Mission, *Geophys. Res. Lett.*, 32(21), L21S01.
- Smith, D.E., Zuber, M.T., Neumann, G.A., et al. (2009), Early results from the Lunar Orbiter Laser Altimeter on LRO, *Eos, Trans. AGU* 90(52), Fall Meet. Suppl., Abstract U21C-05.
- Smith, D.E., Zuber, M.T., Sun, X., Neumann, G.A., Cavanaugh, J.F., McGarry, J. F., Zagwodzki, T.W. (2006), Two-way laser link over interplanetary distance, *Science*, 311, pp. 53.
- Torrence, M.H., Zuber, M.T., Smith, D.E., et al. (2009), Initial results from the Lunar Reconnaissance Orbiter Laser Ranging investigation, *Eos, Trans. AGU*, 90(52), Fall Meet. Suppl., Abstract U31A-0005.
- Urschl, C., Beutler, G., Gurtner, W., et al. (2007), Contribution of SLR tracking data to GNSS orbit determination, *Adv. Space Res.*, 39(10), 1515-1523.
- Zuber, M.T., Smith, D.E., Zellar, R.S., et al. (2009), The Lunar Reconnaissance Orbiter laser ranging investigation, *Space Sci. Reviews*, DOI: 10.1007/s11214-009-9511-z.



SECTION 10

MEETINGS

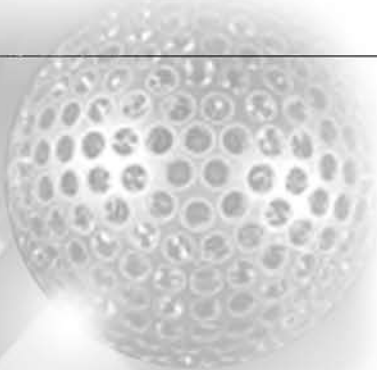

SECTION 10

MEETINGS

Carey Noll/GSFC

The ILRS organizes semi-annual meetings of the Governing Board and annual General Assemblies. General Assembly Meetings are open to all ILRS associates and correspondents. Reports for past Governing Board and Working Group Meetings can be found at: http://ilrs.gsfc.nasa.gov/reports/ilrs_reports/index.html.

ILRS Special Fall 2007 Workshop “Challenges for Laser Ranging in the 21st Century”, Grasse France

Monique Pierron/CERGA



Figure 10-1. Attendees of the 2007 ILRS Workshop in Grasse, France.

The Observatoire de la Cote d’Azur (OCA) in France hosted the Fall 2007 ILRS Workshop “Challenges for Laser Ranging for the 21st Century” in September at the “Palais des Congrès”, in the heart of Grasse, near downtown. The title was broad enough to merge all prospective ideas for constructive future work, and more than ninety participants registered for this meeting. The ILRS Analysis Working Group held a one-day meeting at the venue prior to the fall meeting. The workshop Web site contains presentations, session summaries and photos in full at http://www-g.oca.eu/gemini/ecoles_colloq/colloques/ilrs2007/.

The Workshop opened with a welcome reception in “Fragonard House” and included addresses from Jean Pierre Leleux, the Mayor of Grasse, from Dr. Francis Pierron, the principal organizer, from Dr. Mike Pearlman, the Director of the ILRS Central Bureau, and from Dr. Werner Gurtner, Chair of the ILRS Governing Board.

The sessions, focused on challenges for future, were organized around the following topics:

- Scientific and analysis challenges
- Automation for stations
- Stations operations and data analysis collaborations
- Counters performance and upcoming event timer
- kHz SLR
- Space projects, time transfer, transponder, laser reflector
- New and upgrading stations
- Data formats

After the welcome by Werner Gurtner and Francis Pierron, the session, “What are the Scientific Challenges for the Future” was introduced with review paper presented by Francois Barlier. Subsequent papers included topics such as the TRF and importance of SLR for the scale definition of the next ITRF solution, the latest numerical planetary ephemeris fitted with LLR observations (INPOP06), the next Generation Global Geodetic Networks, and fundamental Physics with Microscope mission were presented.

The session “Operations and Analysts Collaborations to be Developed in the Future”, described the stability of SLR station range biases, SLRF2005 (the temporary ILRS reference frame) a way to find systematic measurements errors in the SLR data, the effect and evaluation of atmospheric gravity and the annual gravity field variation on LAGEOS orbits, and the potential use of Starlette and Ajisai for station positioning.

The second part of this session “Working Together: Station Operations and Data Analysis Groups” focused on the need for better inter- and intra-group communication, the work to remove ambiguities between the various data quality assessments, and the need to move toward developing a comprehensive consolidated analysis report. A key recommendation from the session was that the Network and Engineering, Analysis, and Data Formats and Procedures working groups form a task force to prepare, define, and install concrete procedures and processes for data review and station feedback.

The session “Technological Challenges for the Future” included a section reviewing the status of future transponder missions, including LRO, 3-D imaging lidar technology, T2L2 experiment and transponder ground simulation, and automation experiences at various SLR stations (Zimmerwald, Mt. Stromlo, NGSLR, and Herstmonceux).

The Chronometry session highlighted the need to analyze performance of the counters to calibrate and correct non-linearity of some instruments (especially Stanford counters), and described available and upcoming event timers with impressive performances at the level of a few ps up to sub-ps.

With an increasing number of stations upgrading to kHz ranging capability, the High Repetition Rate session provided recommendations for stations moving in that direction and illustrated the potential of kHz SLR for other applications (atmospheric seeing, satellite spin, etc.).

The “Projects, Missions and Stations” session began with time transfer experiment presentations: Chinese Laser Time Transfer (LTT) and the French Time Transfer by Laser Link (T2L2). Presentations on new or upgraded stations demonstrated that continued high level maintenance and development of instrumentation and network renewal (geometrically and instrumentally) continues within the ILRS and is driven by station and mission requirements as well as research priorities. An interesting conclusion found that inter-station collaboration plays a major role in successful ventures.

The session “Laser Reflector Array for Challenging Orbits” showed that there are more targets in “challenging” orbits, e.g., at 20,000 km, geostationary, or highly elliptic orbits. These new missions illustrated that retroreflector array design must be considered, e.g., a large array for strong returns or a small array to reduce signature effects. Discussions on the types of retroreflectors and testing methodologies were reviewed. Results from successful ranging to Compass and ETS-8 were presented.

The session “Technological Challenges with Data Format presented the status for new ILRS formats, Consolidated Prediction Format (CPF) and Consolidated laser Ranging Data (CRD) format. The errors in the SLR predictions using CPF are minimal. LLR predictions in CPF are used at MLRS. CPF has also been successfully used in testing for transponder mission and LRO predictions. The CRD format design is virtually complete and test data analysis shows little accuracy difference from old format; parallel tests will start by end of year.

The workshop concluded with the ILRS General Assembly followed by a traditional banquet held in “Palais des Congrès”. The final day included a visit to the Grasse observatory and a meeting of the ILRS Governing Board. In addition, the local organizers set up sightseeing tours of Grasse, conducted by a professional guide, for accompanying persons.

16th International Workshop on Laser Ranging, Poznan Poland

Michael Pearlman/CfA

The Committee on Space and Satellite Research of the Polish Academy of Sciences, the Space Research Centre of the Polish Academe of Sciences, the Adam Mickiewicz University in Poznań and the ILRS hosted the 16th International Workshop on Laser Ranging in Poznań, Poland, October 13-17, 2008. The theme of the workshop was “SLR – The Next Generation”. The Web site http://www.astro.amu.edu.pl/ILRS_Workshop_2008/index.php provides information about the workshop; proceedings and session summaries can also be found on the Web at <http://cddis.gsfc.nasa.gov/lw16/>.

Over 140 people from 19 countries participated in the workshop, which included oral and poster presentations on scientific achievements, applications and future requirements, system hardware and software, operations, advanced systems, and analysis. ILRS working group and Governing Board meetings and the ILRS General Assembly were held in conjunction with the workshop. The local organizers also entertained the delegates with a reception and banquet and tours of the Borowiec laser station and Poznan city.

The workshop brought together an exceptional group of researchers who provided reports on the spectrum of science investigations being supported by Satellite and Lunar Laser Ranging (SLR and LLR) and Laser Altimetry. The three sessions comprising this portion of the meeting, containing over twenty oral presentations and three posters, covered a wide range of activities. These sessions were structured as follows.



Figure 10-2. Attendees of the 16th International Workshop on Laser Ranging Poznan, Poland, October 2008.

The first science session focused on the reference frame, positioning SLR stations with high precision within this frame, and time variations in the gravity field, which both perturb the SLR satellite orbits and cause changes of the location of the geocenter with respect to the polyhedron realized by the geographic distribution of the SLR stations. The legacy of SLR over the 1970s and 1980s where it alone provided precise Earth orientation information and through the 1990s for monitoring changes in the longest wavelengths of the gravity field were described. Also presented were results showing the SLR contribution to the International Terrestrial Reference Frame (ITRF) both in terms of providing scale and in monitoring geocenter motion. New missions, like GRACE, which now provide far more detailed information on mass flux within the Earth's system, were also discussed with regard to improving SLR orbit accuracies.

Session two focused on orbit determination capabilities, analyses, and new applications for SLR including support for upcoming Lunar Reconnaissance Orbiter (LRO) mission. This session also discussed various highly interesting investigations made possible through the availability of detailed topographic mapping capabilities delivered by laser altimeters and the Lunar Laser Ranging acquired on the moon. SLR remains one of the surest ways to provide precision orbits in its own right, and for independent orbit verification for solutions produced by GPS and DORIS. A laser transponder being deployed on LRO will provide significantly improved orbits for this lunar orbiter enhancing mission science objectives. The second half of this session focused on the outstanding results for both Earth and Planetary applications, made possible with laser altimetry. Excellent papers were presented on ICESat, the MOLA altimeter flown on Mars Global Surveyor (MGS), and a survey of results from the NEAR, MESSENGER, and LRO spacecraft.

The third science session highlighted SLR and LLR contributions to planetary and lunar geophysics, fundamental physics (e.g. the Lens Thirring effect, the geophysical properties of the moon deduced from LLR) and the upcoming LARES experiment. SLR and LLR, given the long time history and stability of these systems, have made significant contributions to the study of fundamental physics in the field of General Relativity.

The science presentations at this workshop both individually and in total, were some of the most comprehensive ever presented within the ILRS Workshop framework. These papers clearly demonstrated the continuing role that SLR, LLR, and laser altimetry has in furthering our understanding of the dynamics ongoing in the Earth and its terrestrial-like planetary companions.

The session "The Role of Satellite Laser Ranging in the Global Geodetic Observing System" highlighted the central role that SLR plays within GGOS. The opening presentation summarized the main contributions of SLR to the three pillars of geodesy for GGOS with examples of the state-of-the-art in the definition of the origin and scale of the ITRF, the long history of SLR series of EOP, the longest of all space techniques, and mass load variations from long wavelength harmonics time series derived from SLR, with comparisons to other techniques (GRACE, GPS, hydrology, etc.). Efforts on a new ILRS product, daily delivery of fresh EOP estimates, show the product can be used to constrain the EOP forecasting process of the NEOS service of IERS. Other presentations highlighted the intercomparison and combination of SLR with other geodetic techniques. ESA's efforts to harmonize the reduction of GNSS and SLR data with a common analysis package would be an important contribution to GGOS for a combined and consistent estimation of geophysical parameters. Comparison between GPS- and SLR-derived time series of coordinates over a period of eleven years were shown, where the results indicated the general consistency of the results at the few millimeter level. This work demonstrated how well the two techniques compare at sites with data of exceptional quality, and how they can be used to identify problems in either technique when they are co-located and properly and accurately surveyed. Results of optimization studies in designing the future global geodetic networks that will support GGOS, focusing on the role of SLR and the possible products to be delivered, were shown. This presentation stressed the stringent requirements of GGOS and how the synergy of the geodetic techniques will meet this challenge. A poster illustrating the global map of the four networks of the space techniques as they exist today was shown. A second poster showed an example of how ILRS can make use of the Virtual Observatory on the web, following the example of astronomy.

The Network and Station Performance session covered three main topics: data quality control (at stations and at analysis centers), models, and the network in general. Presentations on data quality control reported on efforts to reach and maintain the highest data quality through the use of other on-site geodetic techniques (GNSS, absolute gravity), co-location, automation, and software monitoring development in cooperation with data analysts, engineers, and station operators. Data quality control at Analysis Centers included an overview of the routine quality control system for the ILRS global network provided by the Hitotsubashi University, which is available via web, ftp and email. Results from the re-processing of data from selected missions using the most accurate orbit models and the latest ITRF (SLRF2005) were shown; the analysis has been used in development of a new model, LPOD2005. A presentation was given summarizing an ILRS proposal to IERS for modification of the analysis standards related to the products contributing to the establishment of future ITRF solutions. Analysis of the correlation between the TRF datum and the ILRS network geometry was shown with the goal to explain the discontinuity in the SLR scale. Difficulties in tracking the future TanDEM-X mission were discussed with possible remedies for the various types of stations in the ILRS network.

There was significantly more activity in the Lunar Laser Ranging (LLR) and Interplanetary Laser Ranging session this year. A presentation on reference frames for lunar ranging analysis emphasized the need to avoid confusing gauge-dependent terms and physical effects. Two years of APOLLO operation has showed high photon rates and evidence for one-millimeter performance. There were also presentations on recent efforts to understand Earth orientation using 38 years of LLR data and the science that would be attainable with the next-generation (large) corner cubes on the lunar surface. There were several talks on one-way ranging to the lunar reconnaissance orbiter (LRO), focusing on technical parameters/capabilities, pointing strategies and verification, and scheduling and predictions. Preparations for the LRO experiment are taking place at the McDonald Observatory, where most of the software preparation is already completed. There was also a presentation on the science deliverables one may achieve through interplanetary laser ranging, including the successful ranging to the MESSENGER and MGS, as well as plans for LRO. Posters were displayed pertaining to using LLR for Celestial pole determination, and the minimum duration necessary for sea level rise determination.

In the High Repetition Systems Session, the five-year success of the Graz station with two kHz laser operation was reviewed. Other stations including Herstmonceux, Zimmerwald, TIGO, NGSLR, several Chinese stations, a Russian system, and the Potsdam station have or are switching to higher repetition rate laser. New control systems for higher repetition rate lasers have been developed and implemented; most kHz stations are now using the Riga event timer. With the benefit of kHz ranging, several new results and additional areas of study are underway including very accurate satellite spin determination, fast optical response retrieving, mm resolution accuracy from cm targets like LAGEOS and Ajisai, LIDAR applications, seeing measurements, and kHz ranging to a Mars transponder. The SLR future is talking “kHz”.

The Session on Lasers, Detectors and Timers included a review on commercially available kHz diode pumped lasers, and descriptions of a new high voltage Pockels cell driver for kHz SLR lasers, a new saturable absorber for laser transmitters, and a promising narrow-band holographic filters for ranging receivers. A new version of the Riga timer with improved resolution was introduced along with a presentation in the integration of Riga timers into Chinese SLR systems. The design for a commonly used TDC chips for high-speed event timers was presented as were the design and construction of compact event timing and laser fire control device for one-way laser ranging and a new, sub-picosecond timing device. A new photon counting detector for future space missions was also presented.

Several themes ran through the Software and Automation Session; major topics included software modularity and robustness, automation, and remote access to geodetic systems. Also discussed were automated processing of SLR data, CRD file creation, handling, and analysis, SLR predictions, and innovations in telescope pointing. Finally, a topic that has gained importance in the software industry, XML, has been applied to SLR station processing at Stromlo and Riga.

In New and Upgraded Stations, Extended Facilities, the Chinese network stations are being modernized with kHz lasers, event timers, CSPADS, and gravimeters. The Chinese TROS transportable system is operational in the Republic of Korea to support the ARGO project. In France, the new MEO station is operational on both satellites and the Moon, and the mobile FTLRS system has been upgraded with Dassaults event timers for T2L2 project. The Herstmonceux station is testing a new kHz ranging laser and now has an absolute gravimeter operating on site. The Borowiec station has undergone major upgrading, and upgrades on the Simeiz and Katzively stations are underway. In South America, the San Juan SLR station continues to perform exceptionally well and the TIGO system at Concepcion is operational again after delicate optical replacements.

In the session on Operational Issues and New Missions, several reports were given on new missions. Several current and upcoming European missions with retroreflectors including ERS-2, GOCE, and SWARM are focused on Earth sensing and technology applications. SOHLA-1, to be launched in early 2009 by JAXA for a demonstration of small, low cost technical payloads; since the spacecraft will be spinning, it will pose a tracking challenge since access to the retroreflector array will only last a few seconds in every few minute revolution period. Astro-G, a space borne VLBI antenna, is planned for launch in 2012; the highly elliptical orbit and bi-modal, switching operation of the antenna; will also limit normal points to very short intervals and require some special data handling procedures. The Precision Expandable Radar Calibration Satellite being planned by NRL for calibrating radars and studying drag and electromagnetic conditions in orbit will carry over 1000 retroreflectors distributed inside and outside of a spherical deployable frame. Consideration for an Optical Link for the ACES Mission was discussed along with concepts for resolving the range biases in one-way ranging experiments and a novel application of SPADs using no optics. An IR camera and aircraft radio detection beacon using a patched antenna array offers promise of new aircraft detection safety systems for laser ranging. The implementation of the Consolidated Laser Ranging Format is underway with full implementation later in 2009. MOBILAS-8 returned to operations. Posters included some historical SLR information, a status on the ILRS website update, and the upcoming ANDE mission scheduled for May 2009.

Papers presented during the Targets, Signatures, and Biases session covered retro-reflector array design and optical response functions. The continuing development of new missions that will require laser tracking support is evident, as is the ongoing and welcome dialogue between mission engineers and the laser community in developing the best array solutions to maximize the effectiveness of the tracking. Work on retro array design and chamber testing was shown, with particular emphasis on concepts for the next generation GPS satellites. A presentation described experimental results to determine pulse energy levels leaving the telescope as a function of its attitude and initial pulse polarization. Presentations were also given describing the laser arrays on the GEO and MEO elements of the emerging Chinese Compass GNSS and on the HEO two-satellite STSAT-2 technology mission. An optical response simulation was described for the proposed HEO VLBI mission ASTRO-G, which very interestingly will see the ILRS supporting an astrophysics mission.

In the session on Advanced Systems and Techniques: Transponders, Altimeters, and Time Transfer, Altimeters, papers were presented on the development of simulators for planetary exploration and present and future airborne photonic 3D-imaging. Transponder topics included transponder simulations using artificial satellites preliminary hardware designs to demonstrate the feasibility of Mars links. Papers were given on time transfer including first data from T2L2 and some preliminary results from the Chinese LTT experiment and a discussion on One-Way System Calibration Techniques. Other talks included an update on the Russian SLR program including the release of some of the data, a paper on ranging to uncooperative targets in China, and SLR engineering activities at Riga including new developments in their epoch timer work.

Future Workshops

The 17th International Workshop on Laser Ranging is being organized for the University of Concepción, in Concepción, Chile in the January 2011. A full slate of ILRS working group meetings, plus an ILRS Governing Board Meeting and an ILRS General Assembly will be held.

A specialized ILRS Technical Workshop on SLR Tracking of GNSS Constellations is being organized at the Metsovon Conference Center and at the Metsovion Interdisciplinary Research Center of the NTUA in Metsovo, Greece for September 14-18, 2009. The meeting will cover science and applications as well as system and operational issues of SLR tracking on GNSS satellites. Details are available at: http://www.ntua.gr/MIRC/ILRS_W2009/. Several ILRS Working Groups will also meet at this time.

SECTION 11

BIBLIOGRAPHY

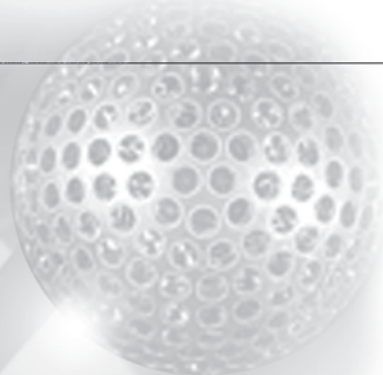

FRASER PANGLOSS



11 | 11

SECTION 11

BIBLIOGRAPHY

Mark Torrence/SGT, Inc., Carey Noll/GSFC

- Abele, M., J. Balodis, M. Caunite, I. Janpaule, A. Rubans, G. Silabriedis, A. Zarinsjh, "Engineering process of SLR for LEO orbiters", 16th International Workshop On Laser Ranging, Poznan Poland, Oct. 13-17, 2008.
- Abele, M., J. Balodis, I. Mitrofanovs, A. Rubans, A. Zarinsjh, "EUPOS-RIGA and SLR EUPOS-RIGA and", Geophysical Research Abstracts, Vol. 10, SRef-ID: 1607-7962/gra/ EGU2008-A-05108, 2008.
- Altamimi, Z., "The International Terrestrial Reference Frame: Lessons from ITRF2005 and Future Developments", Eos Trans. AGU, 88(52), Fall Meet. Suppl., Abstract G41A-03, 2007.
- Altamimi, Z., "Long-term stability of the ITRF origin and scale", Geophysical Research Abstracts, Vol. 9, SRef-ID: 1607-7962/gra/EGU2007-A-03202, 2007.
- Altamimi, Z., "Pre-analysis in view of the next ITRF solution", Geophysical Research Abstracts, Vol. 10, SRef-ID: 1607-7962/gra/EGU2008-A-01869, 2008.
- Altamimi, Z., "Status of ITRF Development and SLR contribution", 16th International Workshop On Laser Ranging, Poznan Poland, Oct. 13-17, 2008.
- Altamimi, Z., X. Collilieux, "Time Series Analysis of ILRS SLR Weekly Solutions", Fall 2007 ILRS Workshop, Grasse France, Sept. 25-28, 2007.
- Andrés de la Fuente, N., "Enhanced modeling of LAGEOS non-gravitational perturbations", PhD report, 321 pp, Delft University of Technology, September 7, 2007.
- Angermann, D., H. Drewes, M. Kruegel, B. Meisel, M. Gerstl, "The effect of different ITRF computation strategies", Geophysical Research Abstracts, Vol. 9, SRef-ID: 1607-7962/gra/EGU2007-A-06917, 2007.
- Angermann D., H. Drewes, M. Gerstl, M. Krügel, B. Meisel, "ITRS Combination Centre at DGFI.. ITRS Combination Centre at DGFI", IERS Annual Report 2006, Bundesamt fuer Kartographie und Geodaesie, Frankfurt a.M. , 2008
- Angermann D., H. Müller, "On the strength of SLR observations to realize the scale and origin of the terrestrial reference frame", IAG Symposia, Vol.133,3-9, Springer 2009.
- Angermann D., H. Drewes, M. Gerstl, M., Krügel, B. Meisel, "DGFI combination methodology for ITRF2005 computation", Proceedings of the IAG Symposium Geodetic Reference Frames GRF 2006 Munich, Springer, 2009, in press.
- Appleby, G., M. Wilkinson, S. Williams, M. Ziebart, V. Smith, "Stability of the Herstmonceux space geodetic site from multi-technique analyses", Geophysical Research Abstracts, Vol. 9, SRef-ID: 1607-7962/gra/ EGU2007-A-08495, 2007.
- Appleby, G., T. Otsubo, P. Gibbs, "Further improvements in understanding subtle systematic effects in laser ranging data", Geophysical Research Abstracts, Vol. 9, SRef-ID: 1607-7962/gra/EGU2007-A-07720, 2007.
- Appleby, G., P. Gibbs, NSGF, UK, "Robust pre-processing of kHz rate laser observations", Fall 2007 ILRS Workshop, Grasse France, Sept. 25-28, 2007.
- Appleby, G, M. Wilkinson, V. Smith, "Analysis of vertical motion at Herstmonceux from satellite geodesy and absolute gravity", Geophysical Research Abstracts, Vol. 10, SRef-ID: 1607-7962/gra/EGU2008-A-08308, 2008.
- Appleby, G., P. Gibbs, T. Otsubo, "Improvements in understanding of systematic effects in laser ranging observations", Geophysical Research Abstracts, Vol. 10, SRef-ID: 1607-7962/gra/EGU2008-A-09261, 2008.
- Appleby, G., M. Wilkinson, V. Luceri, P. Gibbs, V. Smith, "Attempts to separate apparent observational range bias from true geodetic signals", 16th International Workshop On Laser Ranging, Poznan Poland, Oct. 13-17, 2008.

- Appleby, G., V. Smith, M. Wilkinson, M. Ziebart, S. Williams, "Height signals determined from SLR, absolute gravity and GPS observations at the Space Geodesy Facility, Herstmonceux, UK", *Eos Trans. AGU*, 89(53), Fall Meet. Suppl., Abstract G33A-0670, 2008.
- Argus, D, R. Gordon, W. Peltier, "The Translation and Rotation With Which to Define the North American plate", *Eos Trans. AGU*, 88(52), Fall Meet. Suppl., Abstract G21B-0491, 2007.
- Argus, D., "At What Exact Velocity is Earth's Center Moving?", *Eos Trans. AGU*, 88(52), Fall Meet. Suppl., Abstract G41A-04, 2007.
- Argus, D., W. Peltier, "Constraining Models of Postglacial Rebound Using Space Geodesy", *Eos Trans. AGU*, 89(53), Fall Meet. Suppl., Abstract G31A-0646, 2008.
- Arnold, D., "Cross Section of the ETS-VIII Retroreflector Array", Fall 2007 ILRS Workshop, Grasse France, Sept. 25-28, 2007.
- Arnold, D., "Signal Strength Measurements and Retroreflector Array Design", 16th International Workshop On Laser Ranging, Poznan Poland, Oct. 13-17, 2008.
- Arnold, D., G. Bellettini, A. Boni, A. Cantone, I. Ciufolini, D. G. Currie, S. Dell-Agnello, G.O. Delle Monache, M.A. Franceschi, M. Garattini, N. Intaglietta, A. Lucantoni, M. Martini, T. Napolitano, A. Paolozzi, E.C. Pavlis, R. Tauraso, R. Vittori, "Integrated Thermal and Optical Tests of LRAs at the LNF SCF", Fall 2007 ILRS Workshop, Grasse France, Sept. 25-28, 2007.
- Artyukh, Y., V. Bepalko, E. Boole, V. Vedin, "Advances of High-precision Riga Event Timers", 16th International Workshop On Laser Ranging, Poznan Poland, Oct. 13-17, 2008.
- Artyukh, Yu, "Riga event timers: principles of operation and performance characteristics", Fall 2007 ILRS Workshop, Grasse France, Sept. 25-28, 2007.
- Barlier, F., P. Exertier, F. Deleflie, "Scientific and Analysis challenges for the next decade in satellite laser ranging", Fall 2007 ILRS Workshop, Grasse France, Sept. 25-28, 2007.
- Bernhardt, P., "Applications of the Precision Expandable Radar Calibration Target (PERCS)", 16th International Workshop On Laser Ranging, Poznan Poland, Oct. 13-17, 2008.
- Bertrand, O., C. Minazzoli, "Relativistic analysis of an Earth-satellite time transfer", Fall 2007 ILRS Workshop, Grasse France, Sept. 25-28, 2007.
- Biancale, R., J.C. Marty, F. Perosanz, S. Loyer, S. Melachroinos, "Surface load models and validation by space geodesy techniques", *Geophysical Research Abstracts*, Vol. 10, SRef-ID: 1607-7962/gra/EGU2008-A-12066, 2008.
- Bianco, G., V. Luceri, C. Sciarretta, "Stability and consistency of the SLR contribution to the ITRF", *Geophysical Research Abstracts*, Vol. 10, SRef-ID: 1607-7962/gra/EGU2008-A-09217, 2008.
- Bianco, G., V. Luceri, D. Iacovone, "Development of quality control tools for the MLRO", 16th International Workshop On Laser Ranging, Poznan Poland, Oct. 13-17, 2008.
- Bianco, G., V. Luceri, R. Sala, G. Nicoletti, "Working together: the MLRO experience", Fall 2007 ILRS Workshop, Grasse France, Sept. 25-28, 2007.
- Biskupek, L., J. Mueller, "Earth Orientation Parameters from Lunar Laser Ranging", 16th International Workshop On Laser Ranging, Poznan Poland, Oct. 13-17, 2008.
- Biskupek, L., Müller, J., "Lunar Laser Ranging and Earth Orientation; in: *Astrometry, Geodynamics and Astronomical Reference Systems*", Proceedings of Journées "Syst mes de référence spatio-temporels" and X. Lohrmann-Kolloquium, Dresden, Germany, 22.-24.09.2008, submitted 2009.
- Bizouard Ch. , Bolotina O., Bolotin S., "Atmospheric and oceanic normal modes in polar motion", Proc. of the Journées 2008 "Systemes de Reference Spatio-Temporels", Dresden, Germany, September, 22-24, 2008 (in press).
- Blazej, J., I. Prochazka, "New achievements in the simulator of photon counting planetary altimeter", 16th International Workshop On Laser Ranging, Poznan Poland, Oct. 13-17, 2008.
- Blagodyr, Ja., A. Bilinsky, Martynyuk-Lototsky, K., et al. "Overview and Performance of the Ukrainian SLR Station "Lviv-1831", *Artificial Satellites*, Vol.42(1), pp. 9 - 15, 2007. DOI: 10.2478/v10018-007-0014-4.
- Bolotina, O., M. Medvedskij, "Some results of investigation of the stability of the ukrainian SLR stations", *Kinematics and Physics of Celestial Bodies*, Vol. 23, No. 1, pp.11-17, 2007 (in Ukrainian).
- Bolotina O., "Ukrainian SLR network activity in 2007", *Bulletin of the Ukrainian Center of the Earth Orientation Parameters*. No 2. pp 32-33. 2007.

- Bolotina O., "UCEOP archive of the SLR observations", Bulletin of the Ukrainian Center of the Earth Orientation Parameters. No 2. pp 34. 2007.
- Bolotina O., Medvedskij M., "About stability of coordinates estimation of SLR stations", Bulletin of the Ukrainian Center of the Earth Orientation Parameters. No 2. pp 17-20. 2007.
- Bolotina O., Samoilenko A.N., Bolotin S.L. et al., "Investigation of local ties of reference points of collocation station Simeiz-Katzively", Bulletin of the Ukrainian Center of the Earth Orientation Parameters. No 2. pp 21-25. 2007.
- Bolotina O., Medvedskij M., "Some results of investigation of the stability of the Ukrainian SLR stations", Kinematics and Physics of Celestial Bodies. Vol. 23, No 1. pp 11-17. 2007.
- Bolotina O., Bolotin S., Khoda O., Bizouard Ch., "Combination of Different Space Geodetic Techniques: Algorithm of Parameters Estimation", Proc. of the Journées 2007 "Systemes de Reference Spatio-Temporels", Paris, France, September, 17-19, 2007. pp 204-205. 2007.
- Bolotina O., "Review of Ukrainian SLR network activity during 2005-2008", Bulletin of the Ukrainian Center of the Earth Orientation Parameters. No 3. pp 35-37. 2008.
- Bolotina O., Bolotin S., et al., "UCEOP in UB WDC system", Bulletin of the Ukrainian Center of the Earth Orientation Parameters. No 3. pp 32-34. 2008.
- Bolotina O., "Assosiated Analysis Center of SLR observation", Bulletin of the Ukrainian Center of the Earth Orientation Parameters. No 1. pp 80-81. 2008.
- Bolotina O.V., A.N. Samoilenko, S.L. Bolotin, V.L. Kozel, "Investigation of instability of points position of collocation station Simeiz-Katzively", Kinematics and Physics of Celestial Bodies. Vol. 24, No 5. pp 388-400. 2008.
- Bolotina, O., "Ukrainian SLR network", 16th International Workshop On Laser Ranging, Poznan Poland, Oct. 13-17, 2008.
- Boole, E., "The characterization of the Riga Event Timer A032-ET", Fall 2007 ILRS Workshop, Grasse France, Sept. 25-28, 2007.
- Boole, E., V. Vedin, "Potentialities of common-used TDC chips for high-speed event timer design", 16th International Workshop On Laser Ranging, Poznan Poland, Oct. 13-17, 2008.
- Boy, J., P. Gegout, J. Hinderer, S. Luthcke, E. Pavlis, F. Lemoine, D. Rowlands, "Loading effects on time-variable gravity and surface displacements", Eos Trans. AGU, 89(53), Fall Meet. Suppl., Abstract G32A-08, 2008.
- Carman, R., "Geostationary SLR at MOBLAS5 - The ETS-VIII experience", Fall 2007 ILRS Workshop, Grasse France, Sept. 25-28, 2007.
- Chen, C., C. Fan, Z. Li, Y. Zhao, "Development of the Electronic Circuit in High Frequency SLR Based on FPGA", 16th International Workshop On Laser Ranging, Poznan Poland, Oct. 13-17, 2008.
- Chen, J., C. Wilson, E. Pavlis, "Investigation of low-degree gravitational changes from GRACE, Earth rotation, climate models, and satellite laser ranging", Eos Trans. AGU, 89(53), Fall Meet. Suppl., Abstract G32A-01, 2008.
- Chen, W., Y. Fumin, Y. Wang, P. Li, "Laser Retro-reflector Arrays on the Compass Satellites", 16th International Workshop On Laser Ranging, Poznan Poland, Oct. 13-17, 2008.
- Cheng M. K. and B. D. Tapley, "Variations in J2 from GRACE and 33-years of SLR data", PSD1-0042-08, the 37th COSPAR Scientific Assembly, 13-20 July 2008, Montreal, Canada.
- Cheng, M., B.. Tapley, "A 33 Year Time History of the Earth Dynamic Oblateness changes from SLR data", 16th International Workshop On Laser Ranging, Poznan Poland, Oct. 13-17, 2008.
- Cheng, M., B. Tapley, "Recent variation in the Earth Dynamic Oblateness, J2, from SLR data", Eos Trans. AGU, 89(53), Fall Meet. Suppl., Abstract G33A-0673, 2008.
- Chinn, D., K. Le Bail, F. Lemoine, J. Beall, S. Luthcke, D. Rowlands, "Time-varying gravity comparison of the GSFC solutions derived from DORIS, SLR and GRACE", Eos Trans. AGU, 89(53), Fall Meet. Suppl., Abstract G31C-05, 2008.
- Ciufolini, I., A. Paolozzi, E. Pavlis, "Status of the LARES Experiment for Accurate Measurements of Earth Gravitomagnetism", 16th International Workshop On Laser Ranging, Poznan Poland, Oct. 13-17, 2008.

- Clarke, C., J. Horvath, J. McGarry, T. Zagwodzki, C. Noll, D. Carter, M. Torrence, G. Neuman, "LR-LRO Data Flow and Scheduling Operations", 16th International Workshop On Laser Ranging, Poznan Poland, Oct. 13-17, 2008.
- Clarke, C., R. Ricklefs, J. McGarry, "LRO predictions", Fall 2007 ILRS Workshop, Grasse France, Sept. 25-28, 2007.
- Collilieux, X., B. Garayt, Z. Altamimi, B. Cannelle, J. Chatillon, S. Halard, T. Rugi, X. Thauvin, "A new ITRF web site based on GIS application", Geophysical Research Abstracts, Vol. 9, SRef-ID: 1607-7962/gra/EGU2007-A-07292, 2007.
- Collilieux, X., D. Coulot, P. Berio, Z. Altamimi, "What could explain the relative scale bias estimated between SLR and VLBI solutions used in the ITRF2005 analysis?", Geophysical Research Abstracts, Vol. 9, SRef-ID: 1607-7962/gra/EGU2007-A-08134, 2007.
- Collilieux, X., D. Coulot, Z. Altamimi, "Coordinate time series comparison. Application to ITRF2005 height residuals time series", Geophysical Research Abstracts, Vol. 9, SRef-ID: 1607-7962/gra/EGU2007-A-08161, 2007.
- Collilieux, X., Z. Altamimi, T. van Dam, D. Coulot, J. Ray, "Impact of loading effects on the Terrestrial Reference Frame determination", Geophysical Research Abstracts, Vol. 10, SRef-ID: 1607-7962/gra/EGU2008-A-06252, 2008.
- Combrinck, L., "Evaluation of PPN parameter Gamma as a test of General Relativity using SLR data", 16th International Workshop On Laser Ranging, Poznan Poland, Oct. 13-17, 2008.
- Combrinck, L., C. Bollig, F. Pierron, "Conceptual design of LLR for South Africa", Fall 2007 ILRS Workshop, Grasse France, Sept. 25-28, 2007.
- Coulot, D., P. Berio, D. Feraudy, O. Laurain, P. Exertier, "Satellite Laser Ranging biases and Terrestrial Reference Frame scale factor", Geophysical Research Abstracts, Vol. 9, SRef-ID: 1607-7962/gra/EGU2007-A-07027, 2007.
- Currie, D.G., S. Dell'Agnello, G.O. Delle Monache, R. Vittori et al, "Status of the LLRRA21/MoonLIGHT NASA LSSO project", 16th International Workshop On Laser Ranging, Poznan Poland, Oct. 13-17, 2008.
- Degnan, J., "Emerging Technologies", Fall 2007 ILRS Workshop, Grasse France, Sept. 25-28, 2007.
- Degnan, J., "Recent Progress in Photon-counting 3D Imaging Lidars", Fall 2007 ILRS Workshop, Grasse France, Sept. 25-28, 2007.
- Degnan, J., "Globally contiguous, high resolution topographic mapping of planets and moons via photon-counting", 16th International Workshop On Laser Ranging, Poznan Poland, Oct. 13-17, 2008.
- Degnan, J., "Impact of Receiver Deadtime on Photon-Counting SLR and Altimetry during Daylight Operations", 16th International Workshop On Laser Ranging, Poznan Poland, Oct. 13-17, 2008.
- Degnan, J., J. McGarry, T. Zagwodzki, T. Varghese, "Transmitter Point-Ahead using Dual Risley Prisms: Theory and Experiment", 16th International Workshop On Laser Ranging, Poznan Poland, Oct. 13-17, 2008.
- Deleflie, F., P. Exertier, O. Laurain, D. Feraudy, J.-M. Lemoine, "Temporal variations of the Earth gravity field derived from SLR Data over a long period of time", 16th International Workshop On Laser Ranging, Poznan Poland, Oct. 13-17, 2008.
- Deleflie, F., S. Lambert, P. Exertier, A.-M. Gontier, C. Barache, "The Virtual Observatory in Geodesy and Earth's Sciences: The French activities", 16th International Workshop On Laser Ranging, Poznan Poland, Oct. 13-17, 2008.
- Dell'Agnello, S., G.O. Delle Monache, D.G. Currie, R. Vittori, et al, "Status of the INFN Satellite/lunar laser ranging Characterization Facility (SCF)", 16th International Workshop On Laser Ranging, Poznan Poland, Oct. 13-17, 2008.
- Devoti, R., G. Bianco, V. Luceri, C. Sciarretta, "ITRF2005: evaluation of its consistency", Geophysical Research Abstracts, Vol. 9, SRef-ID: 1607-7962/gra/EGU2007-A-09227, 2007.
- Ding, J., F. Qu, Z. Wei, "SLR Data Automatic Preprocessing", 16th International Workshop On Laser Ranging, Poznan Poland, Oct. 13-17, 2008.
- Dunn, P., H. Matsumoto, M. Torrence, "Vertical motion at Laser Observatories", Geophysical Research Abstracts, Vol. 9, SRef-ID: 1607-7962/gra/EGU2007-A-10009, 2007.
- Dunn, P., "Quality Assessment of SLR Observations", Fall 2007 ILRS Workshop, Grasse France, Sept. 25-28, 2007.
- Dunn, P., C. Clarke, M. Torrence, "NGSLR Performance in High and Low Energy Operation", 16th International Workshop On Laser Ranging, Poznan Poland, Oct. 13-17, 2008.

- Dunn, P., Christopher Clarke, "Characteristics of an eye-safe Kilohertz instrument", Fall 2007 ILRS Workshop, Grasse France, Sept. 25-28, 2007.
- Fan, C., X. Dong, X. Han, Y. Zhao, "Development of Any Frequency Fire Rate SLR Control System", 16th International Workshop On Laser Ranging, Poznan Poland, Oct. 13-17, 2008.
- Feissel-Vernier, M., O. de Viron, K. Le Bail, "Stability of VLBI, SLR, DORIS, and GPS positioning", Eos Trans. AGU, 88(52), Fall Meet. Suppl., Abstract G41A-07, 2007.
- Flohrer, C., "Mutual validation of satellite-geodetic techniques and its impact on GNSS orbit modeling", PhD Thesis. Geodätisch-geophysikalische Arbeiten in der Schweiz, Vol. 75, 2008.
- Forbes, M. Craymer, J. Henton, T. Herron, S. Kokelj, E. Lapelle, G. Manson, P. Marsh, S. Mazzotti, M. Piraszewski, S. Solomon, D. Whalen, "Combining Geological, Geodetic, and Tide-Gauge Data to Estimate Coastal Subsidence and Flooding Hazards in the Mackenzie Delta, Western Arctic Canada", Eos Trans. AGU, 88(52), Fall Meet. Suppl., Abstract G51A-0136, 2007.
- Fumin, Y., B. Wu, Z. Zhang, T. Guo, "Upgrading Plan of the Chinese SLR Network", 16th International Workshop On Laser Ranging, Poznan Poland, Oct. 13-17, 2008.
- Fumin, Y., C. Wanzhen, Z. Zhongping, W. Yuanming, Z. Haifeng, Z. You, F. Cunbo, H. Xingwei, "The LRA on Compass M1 and Laser Ranging Experiment", Fall 2007 ILRS Workshop, Grasse France, Sept. 25-28, 2007.
- Fumin, Y., H. Peicheng, I. Prochazka, Z. Zhongping, C. Wanzhen, W. Yuanming, Z. Haifeng, Z. You, F. Cunbo, H. Xingwei, "Situation of the LTT experiment", Fall 2007 ILRS Workshop, Grasse France, Sept. 25-28, 2007.
- Fumin, Y., P. Huang, Z. Zhang, W. Chen, H. Zhang, Y. Wang, W. Meng, J. Wang, G. Zou, Y. Liao, L. Wang, I. Prochazka, Y. Zhao, C. Fan, X. Han, "Preliminary Results of the Laser Time Transfer (LTT) Experiment", 16th International Workshop On Laser Ranging, Poznan Poland, Oct. 13-17, 2008.
- Fumin, Y., Z. Zhang, J. Chen, W. Chen, Z. Wu, H. Zhang, I. Prochazka, "Preliminary Results of Laser Ranging to Un-cooperative Targets at Shanghai SLR", 16th International Workshop On Laser Ranging, Poznan Poland, Oct. 13-17, 2008.
- Gambis, D., C. Bizouard, Z. Altamimi, Z., "Monitoring the consistency between ITRF2005 and IERS Earth Orientation Parameters", Geophysical Research Abstracts, Vol. 10, SRef-ID: 1607-7962/gra/EGU2008-A-03920, 2008.
- Gambis, D., R. Biancale, G. Bourda, S. Loyer, L. Soudarin, F. Defl'ie, "Comparison of GRGS EOP+TRF combined solution to intra-technique combinations", Geophysical Research Abstracts, Vol. 9, SRef-ID: 1607-7962/gra/EGU2007-A-08658, 2007.
- Gambis, D., Z. Altamimi, J. Ray, "Maintenance of the IERS EOP and ITRF2005 Consistency", Geophysical Research Abstracts, Vol. 9, SRef-ID: 1607-7962/gra/EGU2007-A-08366, 2007.
- Gambis, D., Z. Altamimi, J. Richard, "Monitoring the ITRF/EOP consistency", Eos Trans. AGU, 89(53), Fall Meet. Suppl., Abstract G33B-0696, 2008.
- Gibbs, P., G. Appleby, "Progress with understanding counter non-linearity effects", Fall 2007 ILRS Workshop, Grasse France, Sept. 25-28, 2007.
- Gibbs, P., G. Appleby, D. Benham, C. Potter, R. Sherwood, T. Shoobridge, V. Smith, M. Wilkinson, "Herstmonceux - towards kHz ranging and multi-technique status", 16th International Workshop On Laser Ranging, Poznan Poland, Oct. 13-17, 2008.
- Gipson, J., D. Behrend, C. Ma, C. Meertens, M. Pearlman, A. Nothnagel, P. Sarti, C. Aiken, K. Fancher, J. Foster, J. Richardson, D. Lokken, J. Long, D. Stowers, "Report of Informal Working Group on Measuring and Monitoring Site Ties", Eos Trans. AGU, 89(53), Fall Meet. Suppl., Abstract G33A-0665, 2008.
- Glotov, V., T. Ivantieva, Vladimir Mitrikas, Mikhail Zinkovsky, "About one way to the exception of the systematic measurements errors in the processing of the biases SLR data", Fall 2007 ILRS Workshop, Grasse France, Sept. 25-28, 2007.
- Govind, R., F. Lemoine, N. Zelensky, "Evaluating the effect of atmospheric gravity and annual gravity field variation on Lageos orbits", Fall 2007 ILRS Workshop, Grasse France, Sept. 25-28, 2007.
- Govind, R. F. Lemoine, Z. Altamimi, K. Le Bail, D. Chinn, "The Contribution of Starlette/Stella SLR to Terrestrial Reference Frame Definition", Eos Trans. AGU, 88(52), Fall Meet. Suppl., Abstract G42A-02, 2007.
- Govind, R. "The value of SLR observations to GNSS: The potential for Terrestrial Reference Frame Definition", International GNSS Symposium, Sydney, December 2007.

- Greaves M., R.M. Bingley, D.F. Baker, G. Appleby, "National report of Great Britain, 2008", Report on the Symposium of the IAG Subcommittee for the European Reference Frame (EUREF), June 2008.
- Griffiths, J., J. Ray, "On the Accuracy of IGS Orbits", Eos Trans. AGU, 88(52), Fall Meet. Suppl., Abstract G11A-03, 2007.
- Gross, R., "Laser Ranging Contributions to Earth Rotation Studies", 16th International Workshop On Laser Ranging, Poznan Poland, Oct. 13-17, 2008.
- Gross, R., "The Contribution of Laser Ranging to the Global Geodetic Observing System", 16th International Workshop On Laser Ranging, Poznan Poland, Oct. 13-17, 2008.
- Guilfoyle, J., H. Kunimori, "kHz Ranging Engine", Fall 2007 ILRS Workshop, Grasse France, Sept. 25-28, 2007.
- Gurtner, W., "CPF Prediction Errors", Fall 2007 ILRS Workshop, Grasse France, Sept. 25-28, 2007.
- Gurtner, W., "Station and AC collaboration: setting the stage", Fall 2007 ILRS Workshop, Grasse France, Sept. 25-28, 2007.
- Gurtner, W., E. Pop, J. Utzinger, "kHz in Zimmerwald", Fall 2007 ILRS Workshop, Grasse France, Sept. 25-28, 2007.
- Gurtner, W., E. Pop, J. Utzinger, "The New 100-Hz Laser System in Zimmerwald: Concept, installation and first experiences", 16th International Workshop On Laser Ranging, Poznan Poland, Oct. 13-17, 2008.
- Gurtner, W., "Automation: Prerequisites", Fall 2007 ILRS Workshop, Grasse France, Sept. 25-28, 2007.
- Heflin, M., "Transformation of GPS Time Series to ITRF2005", Eos Trans. AGU, 88(52), Fall Meet. Suppl., Abstract G43C-1468, 2007.
- Hidalgo, I., A. Mozo, P. Navarro, R. Piriz, D. Navarro-Reyes, "Use of SLR Observations to improve Galileo GIOVE-B Orbit and Clock Determination", 16th International Workshop On Laser Ranging, Poznan Poland, Oct. 13-17, 2008.
- Hiener, M., U. Schreiber, U. Hugentobler, "BepiColombo Laser Altimeter Simulator", 16th International Workshop On Laser Ranging, Poznan Poland, Oct. 13-17, 2008.
- Huber, H., M. Schmidt, S. Zoppel, "Advances of multi kHz repetition rate picosecond laser system for satellite laser ranging", 16th International Workshop On Laser Ranging, Poznan Poland, Oct. 13-17, 2008.
- Hulley, G.C., E.C. Pavlis, "A ray tracing technique for improving Satellite Laser Ranging atmospheric delay corrections, including the effects of horizontal refractivity gradients", J. Geophys. Res., 112, B6, DOI: 10.1029/2006JB004834, 2007.
- Ignatenko, Y., V. Tryapitsyn, A. Makeyev, I. Ignatenko, "Measurment of Anomalous Angle of Deviation of Light During Satellite Laser Ranging", 16th International Workshop On Laser Ranging, Poznan Poland, Oct. 13-17, 2008.
- Inoue, T., S. Nakamura, R. Nakamura, K. Yoshihara, H. Kunimori, T. Otsubo, "SLR Return Analysis for SOHLA-1", 16th International Workshop On Laser Ranging, Poznan Poland, Oct. 13-17, 2008.
- Inoue, T., S. Nakamura, R. Nakamura, K. Yoshihara, H. Takeuchi, H. Kunimori, T. Otsubo, "SLR Return Analysis for Astro-G", 16th International Workshop On Laser Ranging, Poznan Poland, Oct. 13-17, 2008.
- Iqbal, F., F. Koidl, G. Kirchner, "Medium Resolution Event Timer and Range Gate Generator in Graz FPGA Card", 16th International Workshop On Laser Ranging, Poznan Poland, Oct. 13-17, 2008.
- Johnston, G., "Enhancement of Australia's National Geospatial Reference System", Geophysical Research Abstracts, Vol. 9, SRef-ID: 1607-7962/gra/EGU2007-A-11408, 2007.
- Kim, K., S.H. Lee, J.H. Lee, J. Jin, N.H. Myung, "SLR Coverage Analysis for STSAT-2", 16th International Workshop On Laser Ranging, Poznan Poland, Oct. 13-17, 2008.
- Kirchner, G., D. Kucharski, E. Cristea, W. Hausleitner, S. Schillak, "Spin parameters determination from kHz SLR data", Fall 2007 ILRS Workshop, Grasse France, Sept. 25-28, 2007.
- Kirchner, G., W. Hausleitner, E. Cristea, "AJISAI Spin Parameter Determination using Graz kHz Satellite Laser Ranging Data", IEEE Transactions on Geoscience and Remote Sensing, Vol. 45, No. 1, pp 201-205, January 2007.
- Kirchner, G., D. Kucharski, F. Koidl, "Millimeter Accuracy from Centimeter Targets", 16th International Workshop On Laser Ranging, Poznan Poland, Oct. 13-17, 2008.
- Kirchner, G., F. Koidl, D. Kucharski, "Advantages, Experiences, Additional Possibilities", Fall 2007 ILRS Workshop, Grasse France, Sept. 25-28, 2007.

- Kirchner, G., F. Koidl, Daniel Kucharski, “Graz kHz SLR LIDAR: First Results”, 16th International Workshop On Laser Ranging, Poznan Poland, Oct. 13-17, 2008.
- Kodet, J., I. Prochazka, “Compact Event Timing and Laser Fire Control Device for One Way Laser Ranging”, 16th International Workshop On Laser Ranging, Poznan Poland, Oct. 13-17, 2008.
- Koelbl, J., M. Froeschl, A. Seedsman, Y. Gao, M. Dawson, “Fast Switching Pockels Cell Driver for SLR Laser System”, 16th International Workshop On Laser Ranging, Poznan Poland, Oct. 13-17, 2008.
- Koenig, D., R. Koenig, K.H. Neumayer, M. Rothacher, “Geodetic Earth System Parameters from GPS/CHAMP/GRACE Integrated Processing”, Geophysical Research Abstracts, Vol. 9, SRef-ID: 1607-7962/gra/EGU2007-A-09823, 2007.
- Koenig, R., F. Flechtner, M. Thomas, “Long-term Atmosphere and Ocean Induced Mass Variations and an Example of their Use in SLR Analysis”, Geophysical Research Abstracts, Vol. 10, SRef-ID: 1607-7962/gra/EGU2008-A-06997, 2008.
- Koenig, R., K.H. Neumayer, M. Vei, “Some Effects of Data Handling and Background Models on the SLR Dynamical and Geometrical Reference Frame”, Geophysical Research Abstracts, Vol. 9, SRef-ID: 1607-7962/gra/EGU2007-A-03874, 2007.
- Kopeikin, S., “Millimeter Laser Ranging to the Moon: a comprehensive theoretical model for advanced data analysis”, 16th International Workshop On Laser Ranging, Poznan Poland, Oct. 13-17, 2008.
- Kopeikin, S.M., E. Pavlis, D. Pavlis, V.A. Brumberg, A. Escapa, J. Getino, A. Gusev, J. Mueller, W.T. Ni, N. Petrova, “Prospects in the orbital and rotational dynamics of the Moon with the advent of sub-centimeter lunar laser ranging”, *Advances in Space Research*, 42, 1378-1390, 2008.
- Kral, L., I. Prochazka, “Atmospheric seeing studies based on kHz mm SLR in Graz”, Fall 2007 ILRS Workshop, Grasse France, Sept. 25-28, 2007.
- Krasinsky, G., “Estimating the dynamical Love number k_2^d from the analysis of the laser ranging data of LAGEOS-1 and LAGEOS-2”, *Transactions of IAA*, 2009 (in press).
- Kruegel, M., B. Meisel, V. Tesmer, D. Angermann, “Computation of a Terrestrial Reference Frame based on homogeneously processed data of different space geodetic techniques”, *Eos Trans. AGU*, 88(52), Fall Meet. Suppl., Abstract G43C-1467, 2007.
- Krügel, M., D. Angermann, H. Drewes, M. Gerstl, B. Meisel, V. Tesmer, D. Thaller, “GGOS-D Reference Frame Computations”, *GEOTECHNOLOGIEN Science Report*, No. 11, ISSN 1619-7399, 2007a.
- Kucharski, D., G. Kirchner, F. Koidl, J. Weingrill, “16 years of LAGEOS-2 Spin Data: From launch to present”, 16th International Workshop On Laser Ranging, Poznan Poland, Oct. 13-17, 2008.
- Kuzmicz-Cieslak, M., E. Pavlis, “Implementing the new ILRS CRD data format”, 16th International Workshop On Laser Ranging, Poznan Poland, Oct. 13-17, 2008.
- LaBrecque, J., J. Miller, M. Pearlman, “A Recommendation on SLR Ranging to Future Global Navigation Satellite Systems”, *Eos Trans. AGU*, 89(53), Fall Meet. Suppl., Abstract G41C-0631, 2008.
- Lavallee, D., P. Moore, E. Petrie, M. King, P. Clarke, D. Booker, “Can we measure Geocenter Motion accurately?”, *Eos Trans. AGU*, 89(53), Fall Meet. Suppl., Abstract G33B-0694, 2008.
- Le Bail, K., F. Lemoine, D. Chinn, J. Beall, “The common signal of the geocenter motion in the DORIS and SLR time series”, *Eos Trans. AGU*, 89(53), Fall Meet. Suppl., Abstract G51A-0607, 2008.
- Lee S.H., K. Kim, J.H. Lee, J. Jin, N.H. Myung, “Laser Retroreflector Array Development for STSAT-2”, 16th International Workshop On Laser Ranging, Poznan Poland, Oct. 13-17, 2008.
- Legrand, J., Z. Altamimi, O. Jamet, “Explicit application of the No-Net-Rotation Condition over an interpolated ITRF2005 velocity field using least squares collocation method”, Geophysical Research Abstracts, Vol. 9, SRef-ID: 1607-7962/gra/EGU2007-A-07143, 2007.
- Lejba, P., “Determination of SLR stations coordinates and velocities on the basis of laser observations of low satellites”, Geophysical Research Abstracts, Vol. 10, SRef-ID: 1607-7962/gra/EGU2008-A-05658, 2008.
- Lejba, P., S. Schillak, “Determination of the SLR station coordinates and velocities on the basis of laser observations of low satellites”, 16th International Workshop On Laser Ranging, Poznan Poland, Oct. 13-17, 2008.
- Lemoine, F., N. Zelensky, E. Pavlis, E. Rowlands, D. Chinn, B. Beckley, J.P. Boy, “Impact of Modelling Improvements on POD for TOPEX/Poseidon and Jason”, Geophysical Research Abstracts, Vol. 10, SRef-ID: 1607-7962/gra/EGU2008-A-11368, 2008.

- Letetrel, C., G. Woppelmann, M. Bouin, Z. Altamimi, F. Martine, A. Santamaria, "ULR Re-analysed Global GPS Solution for Vertical Land Motion Correction at Tide Gauges", *Eos Trans. AGU*, 88(52), Fall Meet. Suppl., Abstract G41A-08, 2007.
- Lidberg, M., M. Nordman, J.M. Johansson, G.A. Milne, H.G. Scherneck, J.L. Davis, "Geodetic Reference Frames in Presence of Crustal Deformations", *Geophysical Research Abstracts*, Vol. 10, SRef-ID: 1607-7962/gra/EGU2008-A-10626, 2008.
- Lim, H.C., G. Tangyong, W. Peiyuan, H.S. Jeon, Y.K. Seo, J.U. Park, Z. Tong, First SLR Operation in Korea using TROS, "Chinese Transportable Ranging Observation System", 16th International Workshop On Laser Ranging, Poznan Poland, Oct. 13-17, 2008.
- Liu, W., Y. Han, E. Actis, E. Alonso, R. Podesta, A.A. Gonzalez, A.M. Pacheco, L. Zhao, C. Liu, Z. Yin, "Actuality and futurity of San Juan 7406 SLR Station", 16th International Workshop On Laser Ranging, Poznan Poland, Oct. 13-17, 2008.
- Loyer, S., F. Perosanz, H. Capdeville, L. Soudarin, "CNES-CLS IGS Analysis Center Activities", *Eos Trans. AGU*, 89(53), Fall Meet. Suppl., Abstract G41C-0632, 2008.
- Luceri, V., G. Bianco, "The site range biases of the worldwide SLR network", Fall 2007 ILRS Workshop, Grasse France, Sept. 25-28, 2007.
- Luceri, V., G. Bianco, "The temporary ILRS reference frame: SLR2005", Fall 2007 ILRS Workshop, Grasse France, Sept. 25-28, 2007.
- Luceri, V., G. Bianco, C. Sciarretta, M. Virelli, "ITRF datum and ILRS network geometry", 16th International Workshop On Laser Ranging, Poznan Poland, Oct. 13-17, 2008.
- Luck, J., C. Moore, "Effects of Ranging in Circular Polarization", 16th International Workshop On Laser Ranging, Poznan Poland, Oct. 13-17, 2008.
- Luck, J., Victoria Smith, Chris Moore, "Circular Polarization Experiment", Fall 2007 ILRS Workshop, Grasse France, Sept. 25-28, 2007.
- Luthcke, S., D. Rowlands, F. Lemoine, H. Zwally, S. Klosko, D. Chinn, J. McCarthy, T. Williams, "ICESat, GRACE, and Time Varying Gravity: SLR Contributions and Applications", 16th International Workshop On Laser Ranging, Poznan Poland, Oct. 13-17, 2008.
- Makeyev, A., "About Current Status of Katzively SLR Station", 16th International Workshop On Laser Ranging, Poznan Poland, Oct. 13-17, 2008.
- Mallama, A., J. McGarry, T. Zagwodzki, J. Cheek, "Pre-Launch Testing of NGSLR Ranging to LRO", 16th International Workshop On Laser Ranging, Poznan Poland, Oct. 13-17, 2008.
- Manche, H., S. Bouquillon, A. Fienga, G. Francou, M. Gastineau, J. Laskar, "Adjustments to LLR data", Fall 2007 ILRS Workshop, Grasse France, Sept. 25-28, 2007.
- Manche H., Bouquillon S., Fienga A., Laskar J., Francou G., Gastineau M., 2007, "Towards INPOP07, ajustements to LLR data", Journées 2007 - Syst mes de références spatio-temporels, Paris, France, N. Capitaine et al. (eds).
- Manche H., J. Laskar, A. Fienga, N. Capitaine, S. Bouquillon, G. Francou, M. Gastineau, 2008, "The geodesic precession in the INPOP ephemerides", Journées.2008 - Syst mes de référence spatio-temporels, Dresden, Germany, M. Soffel, N. Capitaine (eds.).
- Marcus, S., J. Dickey, J. Willis, "Earth Oblateness (J2) Variations on Interannual-Decadal Time Scales: Constraints on Anelastic Effects", *Eos Trans. AGU*, 89(53), Fall Meet. Suppl., Abstract G13A-0633, 2008.
- Martinot-Lagarde, G., "Aiming towards compact versatile ranging lidars", Fall 2007 ILRS Workshop, Grasse France, Sept. 25-28, 2007.
- McGarry J., T. Zagwodzki, R. Ricklefs, G. Neumann, M. Torrence, J. Horvath, C. Clarke, C. Noll, M. Pearlman, "An Update on Laser Ranging to LRO", Fall 2007 ILRS Workshop, Grasse France, Sept. 25-28, 2007.
- McGarry, J., D. Arnold, T. Zagwodzki, J. Degnan, M. Pearlman, "A hollow corner cube design for the GPS III laser retro-reflector arrays", Fall 2007 ILRS Workshop, Grasse France, Sept. 25-28, 2007.
- McGarry, J., T. Zagwodzki, R. Zellar, M. Torrence, J. Horvath, C. Clarke, D. Patterson, J. Cheek, R. Ricklefs, A. Mallama, C. Noll, M. Pearlman, G. Neumann, "Laser Ranging to the Lunar Reconnaissance Orbiter: a Global Network Effort", 16th International Workshop On Laser Ranging, Poznan Poland, Oct. 13-17, 2008.

- McGarry, J., T. Zagwodzki, T. Varghese, J. Degnan, D. Patterson, J. Cheek, C. Clarke, A. Mann, P. Dunn, R. Ricklefs, A. Mallama, "NGSLR: Sharing Eye-safe Kilohertz SLR with Transponder Ranging", 16th International Workshop On Laser Ranging, Poznan Poland, Oct. 13-17, 2008.
- McGarry, J., T. Zagwodzki, T. Varghese, J. Degnan, J. Cheek, A. Mallama, R. Ricklefs, A. Mann, D. Patterson, "Automated tracking at NGSLR (SLR2000) - nearing the final goal", Fall 2007 ILRS Workshop, Grasse France, Sept. 25-28, 2007.
- Medvedsky, M., V.Pap, "The new pointing model of telescope based on tracking data", 16th International Workshop On Laser Ranging, Poznan Poland, Oct. 13-17, 2008.
- Metris, G., "The MICROSCOPE mission: test of the equivalence principle in space", Fall 2007 ILRS Workshop, Grasse France, Sept. 25-28, 2007.
- Moore, C., "A new approach to the generation of output files at Mt Stromlo SLR station", Fall 2007 ILRS Workshop, Grasse France, Sept. 25-28, 2007.
- Moore, C., "Assessing Tracking Performance of High Satellites at Mt Stromlo SLR Station", 16th International Workshop On Laser Ranging, Poznan Poland, Oct. 13-17, 2008.
- Moore, C., "Automation - Recent Progress at Mt Stromlo SLR Station", 16th International Workshop On Laser Ranging, Poznan Poland, Oct. 13-17, 2008.
- Moore, C., "On the Generation of SLR Output Files at Mt Stromlo", 16th International Workshop On Laser Ranging, Poznan Poland, Oct. 13-17, 2008.
- Moore, C., "Re-implementation of automation at Mt Stromlo - a progress report", Fall 2007 ILRS Workshop, Grasse France, Sept. 25-28, 2007.
- Moshkov, V.L., "Narrow-band holographic filters for SLR", 16th International Workshop On Laser Ranging, Poznan Poland, Oct. 13-17, 2008.
- Mueller, H., "Cooperation between Stations and Analysts, Status and Future", Fall 2007 ILRS Workshop, Grasse France, Sept. 25-28, 2007.
- Mueller, H., "International Terrestrial Reference Frame - Latest Developments", 16th International Workshop On Laser Ranging, Poznan Poland, Oct. 13-17, 2008.
- Mueller, H., "The Potential of Starlette and Ajisai for Station Positioning", Fall 2007 ILRS Workshop, Grasse France, Sept. 25-28, 2007.
- Müller, J., L. Biskupek, J. Oberst, U. Schreiber, "Contribution of Lunar Laser Ranging to Realise Geodetic Reference Systems", Reviewed Proceedings of the GRF2006 Meeting, Munich, 9-13. October 2006, 2007.
- Müller, J., "Lunar Laser Ranging - A Science Tool for Geodesy and General Relativity", 16th International Workshop On Laser Ranging, Poznan Poland, Oct. 13-17, 2008.
- Müller, J., "Lunar Laser Ranging: A Space Geodetic Technique to Test Relativity", in: Proceedings of the 11th Marcel Grossmann Meeting, Berlin, 23.-29.07.2006, Kleinert, H.; Jantzen, R.T. & Ruffini, R. (eds.), World Scientific, Part C, 2576-2578, 2008.
- Müller, J., L. Biskupek, "Variations of the gravitational constant from lunar laser ranging data", *Classical and Quantum Gravity*, 24, 4533-4538, 2007.
- Müller, J., M. Soffel, S.A. Klioner, "Geodesy and relativity", *Journal of Geodesy*, 82, 133-145, 2008.
- Müller, J., J.G. Williams, S.G. Turyshev, "Lunar Laser Ranging Contributions to Relativity and Geodesy", in: *Lasers, Clocks and Drag-Free Control: Exploration of Relativistic Gravity in Space*, Dittus, H., Lämmerzahl, C. & Turyshev, S.G. (eds.), Springer, 349, 457-472, 2008.
- Murphy, T.W., K. Nordtvedt, S.G. Turyshev, "Gravitomagnetic Influence on Gyroscopes and on the Lunar Orbit", *Phys. Rev. Lett.* 98, 071102, 2007. [arXiv: gr-qc/0702028]
- Murphy, T.W., E. Adelberger, J. Battat, C. Hoyle, R McMillan, E. Michelsen, C. Stubbs, H. Swanson, "APOLLO: One-millimeter Lunar Laser Ranging", 16th International Workshop On Laser Ranging, Poznan Poland, Oct. 13-17, 2008.
- Murphy, T.W., E. Adelberger, J. Battat, W. Coles, C. Hoyle, K. Kassabian, R. McMillan, J. Melser, E. Michelsen, C. Stubbs, H. Swanson, J. Tu, A. White, "Aircraft Avoidance Technologies", 16th International Workshop On Laser Ranging, Poznan Poland, Oct. 13-17, 2008.

- Murphy, T.W., J. Degnan, W. Farr, W. Folkner, A. Girerd, H. Hemmati, K. Nordtvedt, R. Reasenberg, S. G. Turyshev, J. G. Williams, "Mars Laser Ranging: Science and Design", 16th International Workshop On Laser Ranging, Poznan Poland, Oct. 13-17, 2008.
- Nakamura, S., "ETS-8 and its Laser Reflector Array", Fall 2007 ILRS Workshop, Grasse France, Sept. 25-28, 2007.
- Nicholas, A.C., J.M. Picone, J. Emmert, J. DeYoung, L. Healy, L. Wasiczko, M. Davis, C. Cox, "Preliminary Results from the Atmospheric Neutral Density Experiment Risk Reduction Mission", Proc. of the AAS/AIAA Astrodynamics Specialist Conference, paper #AAS 07-265, Mackinac Island, MI, Aug 20-24, 2007.
- Neidhardt, A., "New ideas in control software for LR-systems with remote assessable, autonomous process cells", 16th International Workshop On Laser Ranging, Poznan Poland, Oct. 13-17, 2008.
- Niedzielski, T., W. Kosek, "Analysis and prediction of altimetric sea level variations during ENSO, and normal conditions", 16th International Workshop On Laser Ranging, Poznan Poland, Oct. 13-17, 2008.
- Nilsson, T., R. Haas, G. Elgered, "Atmospheric turbulence modelling for space geodesy", Geophysical Research Abstracts, Vol. 10, SRef-ID: 1607-7962/gra/ EGU2008-A-08197, 2008.
- Noll, C., "Satellite Laser Ranging Tracking through the Years", 16th International Workshop On Laser Ranging, Poznan Poland, Oct. 13-17, 2008.
- Noll, C., "SLR, GNSS, VLBI, and DORIS Networks: ILRS+IGS+IVS+IDS", 16th International Workshop On Laser Ranging, Poznan Poland, Oct. 13-17, 2008.
- Noll, C., M. Torrence, "ILRS Web Site Update", 16th International Workshop On Laser Ranging, Poznan Poland, Oct. 13-17, 2008.
- Noll, C., "The Global GNSS, SLR, VLBI, and DORIS Networks and their Support of GGOS: IGS+ILRS+IVS+IDS", Eos Trans. AGU, 89(53), Fall Meet. Suppl., Abstract G33A-0664, 2008.
- Oldham, T., H. Donovan, M. Blount, J. Horvath, O. Brogdon, D. McCollums, "Saturable Absorber Laser Upgrade", 16th International Workshop On Laser Ranging, Poznan Poland, Oct. 13-17, 2008.
- Oria, A., B. Brodsky, J. Labrecque, J. Miller, M. Moreau, M. Pearlman, R. Nelson, "Maintenance of the Geodetic Reference Frame in the Global Positioning System", Eos Trans. AGU, 88(52), Fall Meet. Suppl., Abstract G11A-02, 2007.
- Otsubo, T., "Rapid data quality assessment", Fall 2007 ILRS Workshop, Grasse France, Sept. 25-28, 2007.
- Otsubo, T., H. Kunimori, S. Nakamura, H. Takeuchi, Y. Asaki, "Preliminary Design of Retroreflector Array for ASTRO-G in Highly Elliptic Orbit", Fall 2007 ILRS Workshop, Grasse France, Sept. 25-28, 2007.
- Otsubo, T., M. Kobayashi, H. Kunimori, S. Nakamura, H. Takeuchi, "Optical Response Simulation for ASTRO-G Laser Reflector Array", 16th International Workshop On Laser Ranging, Poznan Poland, Oct. 13-17, 2008.
- Otsubo, T., M. Kobayashi, T. Gotoh, T. Kubo-oka, "Multi-Satellite Daily Bias Report: How to Read and Handle it", 16th International Workshop On Laser Ranging, Poznan Poland, Oct. 13-17, 2008.
- Otsubo, T., P. Gibbs, G. Appleby, "kHz Single-Photon Ranging: A Precise Tool to Retrieve Optical Response of Satellites", 16th International Workshop On Laser Ranging, Poznan Poland, Oct. 13-17, 2008.
- Otten, M., T. Springer, D. Navarro-Reyes, P. Femenias, P. Vuilleumier, R. Floberhagen, M. Drinkwater, R. Haagmans, B. Duesmann, J. Dow, "An overview of ESA's upcoming missions equipped with SLR", 16th International Workshop On Laser Ranging, Poznan Poland, Oct. 13-17, 2008.
- Panafidina, N., M. Rothacher, D. Thaller, "Comparison and Combination of SLR Solutions Including Gravity Field Coefficients and Range Biases", 16th International Workshop On Laser Ranging, Poznan Poland, Oct. 13-17, 2008.
- Panek, P., I. Prochazka, "Sub-picosecond event timing - New techniques and first results", Fall 2007 ILRS Workshop, Grasse France, Sept. 25-28, 2007.
- Pap, V., M. Medvedsky, "The methods of converting observation data of SLR between two nearby stations", 16th International Workshop On Laser Ranging, Poznan Poland, Oct. 13-17, 2008.
- Park, J.U., H.C. Lim, Y.K. Seo, Y.S. Kim, J.H. Park, Y.S. Son, Y.K. Kim, "Status and Progress of ARGO", 16th International Workshop On Laser Ranging, Poznan Poland, Oct. 13-17, 2008.
- Pavlis, E., J. Ries, D. MacMillan, M. Kuzmich-Cieslak, C. Ma, D. Rowlands, "Design of next generation global geodetic networks to support GGOS", Geophysical Research Abstracts, Vol. 9, SRef-ID: 1607-7962/gra/EGU2007-A-04934, 2007.
- Pavlis, E.C., "Satellite Center of Mass Correction", Fall 2007 ILRS Workshop, Grasse France, Sept. 25-28, 2007.

- Pavlis, E.C., "Some ideas about the extension of the ILRS products in the near future", Fall 2007 ILRS Workshop, Grasse France, Sept. 25-28, 2007.
- Pavlis, E.C., J.C. Ries, D.S. MacMillan, M. Kuzmicz-Cieslak, C. Ma, and D.D. Rowlands, "Designing a Global Geodetic Network to Support GGOS", Fall 2007 ILRS Workshop, Grasse France, Sept. 25-28, 2007.
- Pavlis, E.C., M. Kuzmicz-Cieslak, "First experience with the new CRD ILRS NP data format", Fall 2007 ILRS Workshop, Grasse France, Sept. 25-28, 2007.
- Pavlis, E.C., M. Kuzmicz-Cieslak, "Quality control of ILRS data and products", Fall 2007 ILRS Workshop, Grasse France, Sept. 25-28, 2007.
- Pavlis, E., "The Origin and Scale of the Terrestrial Reference Frame From Laser Ranging", Eos Trans. AGU, 88(52), Fall Meet. Suppl., Abstract G41A-05, 2007.
- Pavlis, E., J. Ries, D. MacMillan, M. Kuzmicz-Cieslak, C. Ma, D. Rowlands, "Designing a Global Geodetic Network to Support GGOS", Eos Trans. AGU, 88(52), Fall Meet. Suppl., Abstract G32A-07, 2007.
- Pavlis, E., V. Luceri, "Reanalysis and extension of the ILRS weekly products", Geophysical Research Abstracts, Vol. 9, SRef-ID: 1607-7962/gra/EGU2007-A-04963, 2007.
- Pavlis, E., "Weekly SLR series of TRF origin, geocenter variations", Geophysical Research Abstracts, Vol. 10, SRef-ID: 1607-7962/gra/EGU2008-A-05380, 2008.
- Pavlis, E., J. Ries, D. MacMillan, M. Kuzmicz-Cieslak, C. Ma, D. Rowlands, "Next Generation Global Geodetic Networks for GGOS", Geophysical Research Abstracts, Vol. 10, SRef-ID: 1607-7962/gra/EGU2008-A-05388, 2008.
- Pavlis, E., M. Kuzmicz-Cieslak, "Geocenter Motion: Causes and Modeling Approaches", 16th International Workshop On Laser Ranging, Poznan Poland, Oct. 13-17, 2008.
- Pavlis, E., M. Kuzmicz-Cieslak, "SLR and the Next Generation Global Geodetic Networks of low satellites", 16th International Workshop On Laser Ranging, Poznan Poland, Oct. 13-17, 2008.
- Pavlis, E., M. Kuzmicz-Cieslak, P.M. Hinkey, "Improved Modeling Approaches Towards the mm SLR", 16th International Workshop On Laser Ranging, Poznan Poland, Oct. 13-17, 2008.
- Pavlis, E., "Earth System Center to TRF Origin Weekly Series From SLR Analysis", Eos Trans. AGU, 89(53), Fall Meet. Suppl., Abstract G33B-0693, 2008.
- Pavlis, E., J. Ries, D. MacMillan, M. Kuzmicz-Cieslak, D. Rowlands, "The Future Global Geodetic Networks to Support GGOS", Eos Trans. AGU, 89(53), Fall Meet. Suppl., Abstract G31C-03, 2008.
- Pearlman, M., Z. Altamimi, N. Beck, R. Forsberg, W. Gurtner, S. Kenyon, D. Behrend, F.G. Lemoine, C. Ma, C.E. Noll, E.C. Pavlis, Z. Malkin, A.W. Moore, F.H. Webb, R.E. Neilan, J.C. Ries, M. Rothacher, P. Willis, "GGOS Working Group on Networks, Communication, and Infrastructure", Dynamic Planet - Monitoring and Understanding a Dynamic Planet with Geodetic and Oceanographic Tools. Rizos, C., Tregoning, P. (Eds.), IAG Symposia 130, ISBN: 978-3-540-49349-5, 2007.
- Pearlman, M., C. Noll, J. McGarry, W. Gurtner, E. Pavlis, "The International Laser Ranging Service", AOGS 2007, Adv. Geosciences, 2007.
- Petit, G., B. Luzum, "Evolution of IERS Conventions models", Geophysical Research Abstracts, Vol. 9, SRef-ID: 1607-7962/gra/EGU2007-A-09092, 2007.
- Petit, G., B. Luzum, "Towards a new reference edition of the IERS Conventions", Geophysical Research Abstracts, Vol. 10, SRef-ID: 1607-7962/gra/EGU2008-A-01500, 2008.
- Pierron, M., F. Pierron, M. Furia, J.M. Torre, D. Feraudy, E. Samain, Grasse Laser Staff, "FTLRS: Past and current missions, upgrade for future", 16th International Workshop On Laser Ranging, Poznan Poland, Oct. 13-17, 2008.
- Pierron, M., M. Furia, D. Feraudy, F. Pierron, "Grasse Stanford chronometer modeling: Laboratory tests and correction to apply on fixed SLR system and FTLRS before 2004 year", Fall 2007 ILRS Workshop, Grasse France, Sept. 25-28, 2007.
- Plag, H.P., M. Rothacher, M. Pearlman, R. Neilan, C. Ma, "The Global Geodetic Observing System", AOGS 2007, Adv. Geosciences, 2007.
- Pollet, A., D. Coulot, N. Capitaine, S. Nahmani, Z. Altamimi, "Combination of Space Geodetic Techniques at the Measurement Level: Methodological Issues", Eos Trans. AGU, 88(52), Fall Meet. Suppl., Abstract G41A-01, 2007.

- Pollet, A., D. Coulot, N. Capitaine, N., “Combination of space geodetic techniques at the measurement level”, *Geophysical Research Abstracts*, Vol. 10, SRef-ID: 1607-7962/gra/EGU2008-A-06237, 2008.
- Prochazka, I., J. Blazej, “Photon counting detectors for future laser time transfer missions”, 16th International Workshop On Laser Ranging, Poznan Poland, Oct. 13-17, 2008.
- Prochazka, I., J. Blazej, M. Ibrahim, “GPS Timing Receivers Comparison at the SLR in Helwan”, Fall 2007 ILRS Workshop, Grasse France, Sept. 25-28, 2007.
- Prochazka, I., P. Panek, “Progress in sub-picosecond timing system development”, 16th International Workshop On Laser Ranging, Poznan Poland, Oct. 13-17, 2008.
- Ricklefs, R., “Mount mapping”, Fall 2007 ILRS Workshop, Grasse France, Sept. 25-28, 2007.
- Ricklefs, R., “A Summary of Format Activities”, Fall 2007 ILRS Workshop, Grasse France, Sept. 25-28, 2007.
- Ricklefs, R., “MLRS CRD Pilot Implementation”, Fall 2007 ILRS Workshop, Grasse France, Sept. 25-28, 2007.
- Ricklefs, R., C. Noll, J. Horvath, O. Brogdon, E. Pavlis, “Implementing the Consolidated laser Ranging Data (CRD) Format throughout the ILRS Network”, 16th International Workshop On Laser Ranging, Poznan Poland, Oct. 13-17, 2008.
- Riepl, S., “Hektohz Upgrade at TIGO SLR”, Fall 2007 ILRS Workshop, Grasse France, Sept. 25-28, 2007.
- Riepl, S., “Status of the SOS-W”, Fall 2007 ILRS Workshop, Grasse France, Sept. 25-28, 2007.
- Riepl, S., “The SOS-W Calibration Scheme”, Fall 2007 ILRS Workshop, Grasse France, Sept. 25-28, 2007.
- Ries, J., “Satellite laser ranging and the terrestrial reference frame, principal sources of uncertainty in the determination of the scale”, *Geophysical Research Abstracts*, Vol. 9, SRef-ID: 1607-7962/gra/EGU2007-A-10809, 2007.
- Ries, J., R. Eanes, M. Watkins, “Confirming the Frame-Dragging Effect with Satellite Laser Ranging”, 16th International Workshop On Laser Ranging, Poznan Poland, Oct. 13-17, 2008.
- Ries, J.C., “LPOD2005: A Practical Realization of ITRF2005 for SLR-based POD, presented at Ocean Surface Topography Science Team Meeting”, Nice, France, 10-12 November 2008 (<http://www.aviso.oceanobs.com/fileadmin/documents/OSTST/2008/oral/ries.pdf>).
- Ries, J., M. Cheng, S. Bettadpur, D. Chambers, “SLR-determined Low-Degree Geopotential Harmonics and their use With GRACE Data Products”, *Eos Trans. AGU*, 89(53), Fall Meet. Suppl., Abstract G13A-0632, 2008.
- Rutkowska, M., M. Jagoda, “Estimation of the elastic Earth parameters k_2 and k_3 from the SLR technique”, 16th International Workshop On Laser Ranging, Poznan Poland, Oct. 13-17, 2008.
- Sadovnikov, M.A., “Minimization of systematic errors in satellite laser ranging with high pulse repetition rate”, 16th International Workshop On Laser Ranging, Poznan Poland, Oct. 13-17, 2008.
- Salminsh, K., “CPF implementation status in the SLR station Riga”, Fall 2007 ILRS Workshop, Grasse France, Sept. 25-28, 2007.
- Salminsh, K., “SLR station Riga software upgrade”, 16th International Workshop On Laser Ranging, Poznan Poland, Oct. 13-17, 2008.
- Salstein, D.A., C. Long, Y.H. Zhou, K. Quinn, K., “Quality of atmospheric fields for geodetic studies”, *Geophysical Research Abstracts*, Vol. 10, SRef-ID: 1607-7962/gra/EGU2008-A-10566, 2008.
- Samain, E., A. Abchiche, D. Albanese, N. Geyskens, G. Buchholtz, A. Drean, J. Dufour, J. Eysseric, P. Exertier, F. Pierron, M. Pierron, G. Martinot L., J. Paris, J.M. Torre, H. Viot, “MEO: The New French Lunar Laser Ranging Station”, 16th International Workshop On Laser Ranging, Poznan Poland, Oct. 13-17, 2008.
- Samain, E., J.M. Torre, Ph. Guillemot, S. Leon, I. Petitbon, P. Vrancken, “OCA Event Timer”, Fall 2007 ILRS Workshop, Grasse France, Sept. 25-28, 2007.
- Samain, E., Ph. Guillemot, D. Albanese, B. Chauvineau, P. Exertier, S. Leon, O. Minazzoli, F. Para, J. Paris, I. Petitbon, J.-M. Torre, P. Vrancken, J. Weick, “T2L2, Time Transfer by Laser Link, Current status”, Fall 2007 ILRS Workshop, Grasse France, Sept. 25-28, 2007.
- Samain, E., Ph. Guillemot, P. Exertier, D. Albanese, P. Berio, O. Laurain, F. Para, J. Paris, J.-M. Torre, H. Viot, P. Vrancken, I. Petitbon, S. Leon, “Time Transfer by Laser Link - T2L2: First data”, 16th International Workshop On Laser Ranging, Poznan Poland, Oct. 13-17, 2008.
- Samoilenko O., Adamenko O., Bolotina O., Zayets V., Khoda O. “The Results of the Third Geodetic Campaign at the Local Geodynamic Range MAO NAS of Ukraine”, *Kinematics and Physics of Celestial Bodies*. Vol. 24, No 6. pp 452-462. 2008.

- Schillak, S., "The upgrading of the Borowiec SLR station in 2006/2007", Fall 2007 ILRS Workshop, Grasse France, Sept. 25-28, 2007.
- Schillak, S., "The comparison of the reference frames ITRF2000 and ITRF2005 in the determination SLR station positions and velocities", Geophysical Research Abstracts, Vol. 10, SRef-ID: 1607-7962/gra/EGU2008-A-03520, 2008.
- Schillak, S., J. Bartoszak, P. Michalek, "The upgrading of the Borowiec SLR station", 16th International Workshop On Laser Ranging, Poznan Poland, Oct. 13-17, 2008.
- Schillak, S., M. Lehmann, "The comparison of the station coordinates between SLR and GPS", 16th International Workshop On Laser Ranging, Poznan Poland, Oct. 13-17, 2008.
- Schreiber, U., H. Michaelis, A. Neidhardt, P. Lauber, N. Brandl, K.H. Haufe, "Altimetry and Transponder Ground Simulation Experiment", Fall 2007 ILRS Workshop, Grasse France, Sept. 25-28, 2007.
- Schreiber, U., I. Prochazka, "Considerations for an Optical Link for the ACES Mission", 16th International Workshop On Laser Ranging, Poznan Poland, Oct. 13-17, 2008.
- Schreiber, U., M. Hiener, B. Holzapfel, A. Neidhardt, P. Lauber, K.H. Haufe, N. Brandl, J. Oberst, H. Michaelis, "Laser Altimetry and Transponder Ground Based Simulation Experiment", 16th International Workshop On Laser Ranging, Poznan Poland, Oct. 13-17, 2008.
- Schutz, B., H.J. Zwally, "Overview of the Science Results from ICESat", 16th International Workshop On Laser Ranging, Poznan Poland, Oct. 13-17, 2008.
- Sciarretta, C., V. Luceri, G. Bianco, "Quality Assessment of the ILRS EOP 'DAILY' Product", 16th International Workshop On Laser Ranging, Poznan Poland, Oct. 13-17, 2008.
- Selke, C., L. Grunwaldt, "KHz Data Capture, Visualisation, Processing And Storage With Standard Computer and Standard OS", Fall 2007 ILRS Workshop, Grasse France, Sept. 25-28, 2007.
- Seo, Y.K., H.C. Lim, I.K. Park, H.S. Im, J.U. Park, "The Requirements for ARGO Operation System", 16th International Workshop On Laser Ranging, Poznan Poland, Oct. 13-17, 2008.
- Shargorodsky, V.B. Burmistrov, V.D. Glotov, N.N. Parkhomenko, M.A. Sadovnikov, V.D., V.P. Vasiliev, "State of the SLR in Russia", 16th International Workshop On Laser Ranging, Poznan Poland, Oct. 13-17, 2008.
- Shoobridge, T., D. Benham, "One Way System Calibration Techniques", 16th International Workshop On Laser Ranging, Poznan Poland, Oct. 13-17, 2008.
- Sierk, B., M. Avendano, A. Fernandez, V. Moera, C. Guaitiao, R. Castillo, "Field maintenance of the SLR telescope at TIGO", 16th International Workshop On Laser Ranging, Poznan Poland, Oct. 13-17, 2008.
- Smith, D., M. Zuber, "Planetary Laser Altimetry; Past and Present", 16th International Workshop On Laser Ranging, Poznan Poland, Oct. 13-17, 2008.
- Smith, D., M. Zuber, F. Lemoine, M. Torrence, E. Mazarico, "Orbit Determination of LRO at the Moon", 16th International Workshop On Laser Ranging, Poznan Poland, Oct. 13-17, 2008.
- Snopek, K., L. Grunwaldt, R. Koenig, "Challenges of the TerraSAR-X/TanDEM-X formation", 16th International Workshop On Laser Ranging, Poznan Poland, Oct. 13-17, 2008.
- Soffel, M., Klioner, S., Müller, J., Biskupek, L., "Gravitomagnetism and lunar laser ranging", Physical Review D, 78, 024033, 2008.
- Soudarin, L., H. Capdeville, R. Biancale, J. Creataux, J. Lemoine, "Latest evolutions of DORIS data processing at the LEGOS/CLS Analysis Center.", Eos Trans. AGU, 88(52), Fall Meet. Suppl., Abstract G43C-1469, 2007.
- Springer, T., J. Dow, J. Sanchez, I. Romero, "Combined processing of observations from different Global Navigation Satellite Systems", Eos Trans. AGU, 88(52), Fall Meet. Suppl., Abstract G11A-07, 2007.
- Springer, T., M. Otten, N. Romero, J. Dow, "ESOC IGS, IDS, and ILRS (Re-) Processing", 16th International Workshop On Laser Ranging, Poznan Poland, Oct. 13-17, 2008.
- Thaller, D., M. Mareyen, R. Dach, W. Gurtner, G. Beutler, B. Richter, J. Ihde, "Preparing the Bernese GPS Software for the analysis of SLR observations to geodetic satellites", 16th International Workshop On Laser Ranging, Poznan Poland, Oct. 13-17, 2008.
- Thomas, L., "ANDE Concept", 16th International Workshop On Laser Ranging, Poznan Poland, Oct. 13-17, 2008.
- Torrence, M.H., "The ILRS web site as a collaboration tool", Fall 2007 ILRS Workshop, Grasse France, Sept. 25-28, 2007.

- Turyshv S., J.G. Williams, "Space-Based Tests of Gravity with Laser Ranging", *International Journal of Modern Physics* 16 (12a), 2165-2179, doi:10.1142/S0218271807011838, 2007.
- Urschl, C., G. Beutler, W. Gurtner, U. Hugentobler, L. Ostini, M. Ploner, S. Schaer, "Assessing the quality of GNSS orbit models using SLR", *Geophysical Research Abstracts*, Vol. 9, SRef-ID: 1607-7962/gra/EGU2007-A-03911, 2007.
- Varghese, T., J. McGarry, T. Zagwodzki, "NASA NGSLR Precise (~ 1 ns) Transmit Epoch Timing to On-Station Time Reference for LRO Transponder Support", 16th International Workshop On Laser Ranging, Poznan Poland, Oct. 13-17, 2008.
- Vasiliev, V.P., V.D. Shargorodsky, S.B. Novikov, A.A. Chubykin, N.N. Parkhomenko, M.A. Sadovnikov, "Progress in laser systems for precision ranging, angle measurements, photometry, and data transfer", Fall 2007 ILRS Workshop, Grasse France, Sept. 25-28, 2007.
- Vrancken P., E. Samain, D. Albanese, P. Guillemot, F. Para, "The T2L2 Flight Model Calibration and Performance Determination Campaign", Fall 2007 ILRS Workshop, Grasse France, Sept. 25-28, 2007.
- Vrancken, P., E. Samain, U. Schreiber, "Future Applications of Laser Ranging in Space Missions: An Overview", Fall 2007 ILRS Workshop, Grasse France, Sept. 25-28, 2007.
- Welch, Bryan W., "Benefits Derived From Laser Ranging Measurements for Orbit Determination of the GPS Satellite Orbit", NASA/TM-2007-214971, August 2007.
- Wetzel, S., H. Donovan, J. Horvath, D. McCollums, T. Oldham, A. Nelson, D. Patterson, M. Henick, Moblas 8 Return to Operations", 16th International Workshop On Laser Ranging, Poznan Poland, Oct. 13-17, 2008.
- Wiant, J., R. Ricklefs, P. Shelus, "LRO Operations at the MLRS", 16th International Workshop On Laser Ranging, Poznan Poland, Oct. 13-17, 2008.
- Wijaya, D., F. Brunner, "New accurate atmospheric correction of SLR observations", 16th International Workshop On Laser Ranging, Poznan Poland, Oct. 13-17, 2008.
- Wilkinson, M., "High speed Pockels cell shutter and the Herstmonceux MCP-PMT detector", 16th International Workshop On Laser Ranging, Poznan Poland, Oct. 13-17, 2008.
- Wilkinson, M., "Track finding at the Herstmonceux Space Geodesy Facility", Fall 2007 ILRS Workshop, Grasse France, Sept. 25-28, 2007.
- Wilkinson, M., et al, "Experience with kHz SLR at Herstmonceux", Fall 2007 ILRS Workshop, Grasse France, Sept. 25-28, 2007.
- Wilkinson, M., R. Sherwood, G. Appleby, "Analysis of short GPS baselines at SGF Herstmonceux", *Geophysical Research Abstracts*, Vol. 10, SRef-ID: 1607-7962/gra/EGU2008-A-09773, 2008.
- Williams, J.G., S. G. Turyshv, and D. H. Boggs, "Williams, Turyshv, and Boggs Reply", *Phys. Rev. Lett.*, 98, (#5) doi: 10.1103/PhysRevLett.98.059002, (Feb 2) 2007.
- Williams, J.G., "A Scheme for Lunar Inner Core Detection", *Geophysical Research Letters*, 34, L03202, doi:10.1029/2006GL028185, (Feb 9) 2007.
- Williams, J.G., D.H. Boggs and W.M. Folkner, DE421 "Lunar Orbit, Physical Librations, and Surface Coordinates", JPL IOM 335-JW,DB,WF-20080314-001, March 14, 2008.
- Williams, J.G., "Lunar Core and Mantle. What Does LLR See?", 16th International Workshop On Laser Ranging, Poznan Poland, Oct. 13-17, 2008.
- Williams, J.G., S. Turyshv, D.H. Boggs, "Lunar Laser Ranging Tests of the Equivalence Principle with the Earth and Moon", *Int. J. of Modern Physics D*, in press, 2009.
- Wooden, W., W. Kosek, T. vanDam, "IERS Working Group on Prediction: Survey Results", *Geophysical Research Abstracts*, Vol. 9, SRef-ID: 1607-7962/gra/EGU2007-A-04727, 2007.
- Wu, X., "Geocenter motion and reference frame, geophysical and geodetic perspectives", *Geophysical Research Abstracts*, Vol. 9, SRef-ID: 1607-7962/gra/EGU2007-A-04740, 2007.
- Yagudina, E. "Lunar numerical theory EPM2008 from analysis of LLR data", *Proceedings of Journees 2008*, Dresden, 22-24 September 2008 (in press).
- Yatskiv Ya., Bolotina O., Veles O., Sergeeva T., MAO NASU in the structure of the international data base, *Proceedings of IX International scientific conference "System analysis and Information techniques"*, Kiev, Ukraine, 15-17 May, pp 25. 2007.

- Zelensky, N. F. Lemoine, F. B. Beckley, D. Chinn, D. Rowlands, J. Lillibridge, M. Ziebart, A. Sibthorpe, "The New Generation GEOSAT Follow-On Precise Orbit Ephemeris Using ITRF2005 and Other Improvements", *Eos Trans. AGU*, 88(52), Fall Meet. Suppl., Abstract G43C-1474, 2007.
- Zelensky, N., F. Lemoine, B. Beckley, D. Chinn, D. Rowlands, J. Lillibridge, M. Ziebart, A. Sibthorpe, "The New Generation GEOSAT Follow-On Precise Orbit Ephemeris Using ITRF2005 and Other Improvements", *Eos Trans. AGU*, 88(52), Fall Meet. Suppl., Abstract G43C-1474, 2007.
- Zelensky, N., F. Lemoine, D. Rowlands, S. Luthcke, D. Chinn, J. Beall, B. Beckley, S. Klosko, P. Willis, V. Luceri, "Sub-centimeter SLR precision with the SLRF2005/LPOD2005 network", 16th International Workshop On Laser Ranging, Poznan Poland, Oct. 13-17, 2008.
- Zerhouni, W., N. Capitaine, G. Francou, "The contribution of LLR data to the estimation of the celestial pole coordinates", 16th International Workshop On Laser Ranging, Poznan Poland, Oct. 13-17, 2008.
- Zerhouni W., N. Capitaine, G. Francou, 2008, "What could bring LLR observations in determining the position of the celestial pole", *Journées 2008 - Syst mes de référence spatio-temporels*, Dresden, Germany, M. Soffel, N. Capitaine (eds.).
- Zerhouni W., Capitaine N., Francou G., 2008, "The determination of the corrections to the IAU 2000A-2006 X, Y coordinates using LLR observations", *Société astronomique de France*.
- Zerhouni W., Capitaine N., Francou G., 2007, "The use of LLR observations (1969-2006) for the determination of the celestial coordinates of the pole", *Journées 2007 - Syst mes de références spatio-temporels*, Paris, France, N. Capitaine et al. (eds).
- Zhang, Z., Y. Fumin, H. Zhang, Z. Wu, J. Chen, Y. Artyukh, "Applications of Riga Event Timer at Shanghai SLR", 16th International Workshop On Laser Ranging, Poznan Poland, Oct. 13-17, 2008.
- Zhang, Z., Y. Fumin, J. Chen, H. Zhang, Z. Wu, S. Qin, P. Li, "The Experiment of kHz Laser Ranging with Nanosecond Pulses at Shanghai SLR", 16th International Workshop On Laser Ranging, Poznan Poland, Oct. 13-17, 2008.
- Zhao, G., Y. Zhao, M. Sun, H. Yu, "Assessment of SLR observation performance using LAGEOS data", 16th International Workshop On Laser Ranging, Poznan Poland, Oct. 13-17, 2008.
- Zhao, Y., C. Fan, X. Han, G. Zhao, Z. Zhang, X. Dong, "Progress of Changchun SLR", 16th International Workshop On Laser Ranging, Poznan Poland, Oct. 13-17, 2008.
- Zou, R., N. Sneeuw, J. Cai, J. Liu, C. Shi, "The comparison of methods and results by IGN and DGFI in the realization of ITRF2005", *Geophysical Research Abstracts*, Vol. 10, SRef-ID: 1607-7962/gra/EGU2008-A-09368, 2008.
- Zuber, M., D. Smith, "One-Way Ranging to the Planets", 16th International Workshop On Laser Ranging, Poznan Poland, Oct. 13-17, 2008.
- Zuber, M., D. Smith, "Volatile Exchange on Mars", 16th International Workshop On Laser Ranging, Poznan Poland, Oct. 13-17, 2008.

SECTION 12
ILRS ANALYSIS CENTER,
ASSOCIATE ANALYSIS
CENTER, AND LUNAR
ASSOCIATE ANALYSIS
CENTER REPORTS

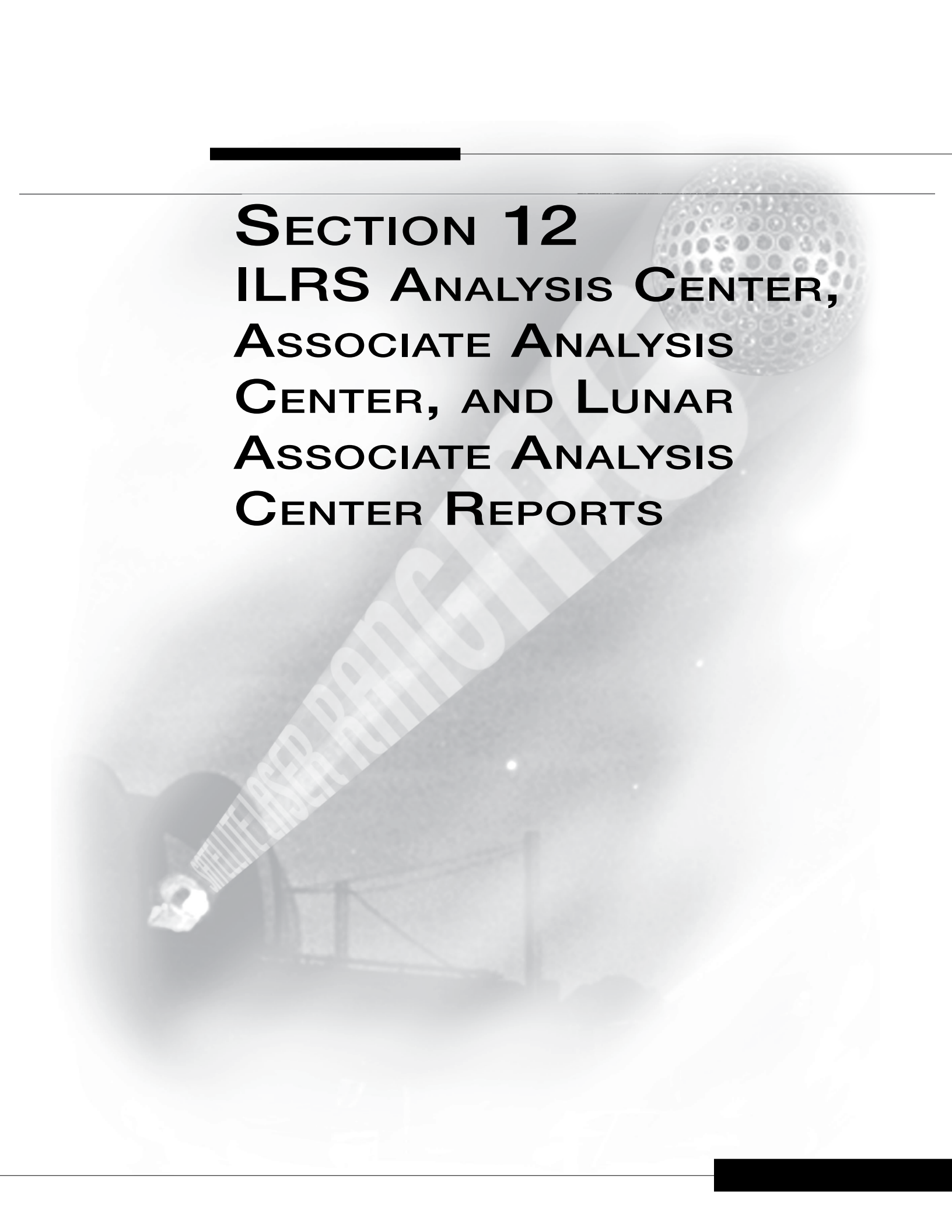
The background of the page is a grayscale image of a lunar surface. In the upper right, there is a spherical object with a grid-like pattern, possibly a probe or a satellite. The rest of the image shows the dark, cratered terrain of the moon. A large, faint watermark reading "NASA PUBLIC DOMAIN" is oriented diagonally across the center of the image. There are also some faint, illegible markings at the bottom of the image, possibly "11", "12", and "13".

SECTION 12

ANALYSIS CENTER REPORTS

ILRS ANALYSIS CENTER REPORTS

Eight centers have been qualified as ILRS Analysis Centers. These centers are required to provide weekly submissions of Earth orientation parameters and station coordinates that are included in the production of the official ILRS combination product. The Analysis Centers are appointed based on their demonstrated performance in both the rigor of their analyses and the punctuality with which their weekly solutions have been submitted to the ILRS Combination Centers.

Italian Space Agency/Space Geodesy Center “G. Colombo” (ASI/CGS)

Giuseppe Bianco/Agenzia Spaziale Italiana, Centro di Geodesia Spaziale, Matera, Italy, Vincenza Luceri/e-GEOS S.p.A., Centro di Geodesia Spaziale, Matera, Italy, Cecelia Sciarretta/Telespazio S.p.A., Roma, Italy

Introduction

The ASI Space Geodesy Center “G. Colombo” (CGS) has contributed to the ILRS since the beginning of the service activities both in its role of fundamental station and analysis center. The SLR data analysis activities at the ASI/CGS started in the 1980’s and, since then, have been focused primarily on global, extended solutions in support of the reference frame maintenance. Due to the multi-technique nature of the CGS mission, geodetic technique combination methods and applications are a top priority objective of the data analysis activities performed at the center.

The ILRS Governing Board recognized the center’s continuous and rigorous contribution and appointed the ASI/CGS as one of the official ILRS Analysis Centers (ACs) when the ILRS AC structure was finalized (2004). In June 2004, the center was selected by the ILRS as its primary official Combination Center (CC) for station coordinates and Earth Orientation Parameters (EOPs).

Information on the CGS and some of the analysis results are available at the CGS web server GeoDAF (Geodetical Data Archive Facility, <http://geodaf.mt.asi.it>).

ILRS Analysis Center

During 2007-2008, the ASI/CGS was deeply involved in the ILRS activities, mainly in support of the reference frame maintenance under the coordination of the Analysis Working Group (AWG). The center’s main contributions were:

- Pos+EOP Products:
 - ◆ Weekly submission of loose coordinate/EOP solutions estimated using LAGEOS and Etalon data and following the ILRS product requirements. These solutions are the ASI/CGS input to the official ILRS combined SSC/EOP product.
 - ◆ Daily submission of loose coordinate/EOP solutions estimated using LAGEOS and Etalon data and following the AWG requirements. The daily product is the ASI/CGS input to the official ILRS combined EOP product, which continues in a testing phase.

- ◆ Weekly orbits: Satellite ephemerides for LAGEOS and Etalon using the solutions of the ILRS ACs will become a future ILRS product. The ASI/CGS estimated state vectors of the four LAGEOS and Etalon satellites are distributed weekly, as requested by the AWG, in the same loose reference frame of the SSC/EOPs as input to the combination.
- ◆ SLRF2005: The latest reference frame ITRF2005 was constructed using the time series of station positions and EOPs provided to the IERS by the IAG Services. The ILRS time series contribution covered the years from 1993 to 2005. This short time span had two main effects on the ITRF2005 calculation: the lack of the older SLR stations and bad estimates for those stations no longer operational in the early 1990's. To overcome these problems, a new TRF was generated from the combination of ITRF2000, ITRF2005, and those new stations starting operations following the development of ITRF2005. This TRF is considered a temporary solution to be used by the AWG until a new ILRS reference frame is constructed from the official ILRS combined weekly solutions.
- ◆ Next ITRF solution: Great effort was devoted to the definition of the AWG guidelines for the ILRS contribution to the next ITRF, mainly regarding the site biases and the core sites for the EOP referencing of the combined weekly product. The main ILRS standard product is a weekly estimate of site coordinates and EOPs over a seven-day arc; the presence of a range bias is immediately mapped in the station coordinates, mainly in the up component. A time series obtained from biased measurements can produce a scale inconsistency with respect to other geodetic techniques and SLR is very sensitive in this sense. On the other hand, the contemporary adjustment of biases and coordinates weakens the solution, causing a large scatter in the coordinate time series, and can absorb geodetic signatures. A good solution seems to be the application of known biases and biases computed with a long arc solution over decades. A bias analysis was performed on LAGEOS data for all the sites of the network for the definition of the bias to be applied in the generation of the next ILRS time series including the information taken from the CDDIS database and the site engineering reports. Different time series of solutions, covering the period 1993-2007, have been produced to test both the a priori SLRF2005 and the adopted biases.
- ◆ Station qualification: ASI/CGS is one of the ACs designated by the AWG to validate the data from new sites. The first two stations undergoing the validation were Golosiiv and Altay.

ILRS Primary Combination Center

In 2007, the ASI-CGS combination activities, within the ILRS frame, were focused on the continuous production of the ILRS official combined weekly solution and its further analysis to prepare the new long term contribution to the ITRF, as well on the preparation of new evolved ILRS combined products, serving future needs of the SLR community, as a more frequent EOP product and a continuous generation of combined SLR orbits for the main geodetic satellites. The center's main contributions as an ILRS Combination Center in 2007-2008 were:

- Pos+EOP Products:
 - ◆ Weekly submission of the ILRS official solution (ILRSA) derived from the combination of individual contributing SLR solutions based on the observations of the LAGEOS-1/-2 and Etalon-1/-2 satellites. The ILRSA solutions contain weekly coordinates of the worldwide SLR tracking network and daily EOPs (X-pole, Y-pole, LOD), ITRF-framed for IERS Bulletin B and EOPC04.
 - ◆ Daily submission of the combined coordinate/EOP solutions computed using the individual AC contributions. The final product will contain daily EOPs, ITRF-framed with a constant, minimum latency of two days. The generation of these daily solutions continues in a testing and evaluation phase.

- ◆ Weekly orbits: the experimental ILRS combined orbit consists of a combined set of state vectors for the LAGEOS-1/-2 and Etalon-1/-2 satellites, aligned to the EOP/SSC weekly product. The ILRS CCs are tasked to develop a combination procedure that will provide an optimal ILRS product from the individual AC orbital solutions. The initial study phase started with the analysis of the available SP3 test files from the ILRS ACs.

Other Activities in 2007-2008

The ASI/CGS analysis activities extended beyond the accomplishment of its role within the ILRS and were addressed in the following main application fields:

- International Terrestrial Reference System (ITRS) maintenance:
 - ◆ Production of IERS-oriented products (global SSC/SSV and EOP time series) regularly performed as contribution to the operational EOP series to assure the CGS contribution to the reference frames establishment. The CGS routinely provides one-day estimated EOP, from LAGEOS and Etalon data, to the IERS.
 - ◆ Generation of the multi-year solution ASI07L01, from LAGEOS-1 and -2 data (1983-2007). Global network SSC/SSV, daily EOP (x, y, LOD), and geocenter (C10, S11, C11) are the main parameters estimated in this solution and available by request.
 - ◆ Tests of the ITRF datum. In the last geodetic reference system, ITRF2005, the SLR time series was not considered in the scale definition mainly for its discontinuity in the time series. Investigations have been carried out to find a possible explanation in the unbalance of the SLR network geometry.
- IERS CPP Pilot Project: Participation to the project in a consortium (ASI, PoliMi, INGV) with the aim to design, implement and maintain the procedures for the rigorous combination of geodetic solution.
- EOP excitation functions: Pre-operational production of the geodetic excitation functions from the ASI/CGS estimated EOP values for the IERS (at present SLR only; the current use of CGS VLBI and GPS EOP is also under testing) to make them available on the ASI geodetic web site (<http://geodaf.mt.asi.it>). The daily geodetic excitation functions are produced every Tuesday along with the operational weekly SLR solution, compared whenever possible with the atmospheric excitation functions from the IERS SBAAM, under the IB and non-IB assumption, including the “wind” term.
- Geodetic solution combination: Realization, implementation and testing of combination algorithms for the optimal merging of global inter- and intra-technique solutions and of regional (e.g., Mediterranean) solutions to densify tectonic information in crucial areas.
 - ◆ Twice a year, ASI-CGS produces a combined velocity solution for the Mediterranean area using its original single-technique velocity solutions (SLR, VLBI, and GPS) that cover the whole data span acquired by the three co-located systems from the beginning of acquisitions in Matera.

The ASIMed solution (http://geodaf.mt.asi.it/html_old/ASImed/ASImed_06.html) gives a detailed picture of the residual velocity field in the area, benefiting from the dense, permanent GPS coverage. The semiannual updating provides improvements in the velocity field information as geodetic sites become stable in terms of their data acquisition history.

Future Plans

Most of the current activities will continue, with particular attention to the ILRS- and IERS-oriented products. Deeper investigations will be directed toward the analysis of the geocenter time series and to the new time series of low degree geopotential zonals.

Contacts

Dr. Giuseppe Bianco
Agenzia Spaziale Italiana (ASI)
Centro di Geodesia Spaziale
C.da Terlecchia, 75100 Matera
ITALY

Voice: +39-0835-377209
Fax: +39-0835-339005
E-mail: giuseppe.bianco@asi.it

Dr. Vincenza Luceri
e-GEOS S.p.A.
Centro di Geodesia Spaziale
C.da Terlecchia, 75100 Matera
ITALY

Voice: +39-0835-377231
Fax: +39-06-40999961
E-mail: cinzia.luceri@telespazio.com

Dr. Cecilia Sciarretta
Telespazio S.p.A.
Via Tiburtina 965, 00156 Rome
ITALY

Voice: +39-06-40793864
Fax: +39-06-40999636
E-mail: cecilia.sciarretta@telespazio.com

Bundesamt für Kartographie und Geodäsie (BKG)

Maria Mareyen, Bernd Richter/BKG

The BKG SLR analysis center is one of the eight ILRS analysis centers that provide weekly and daily solutions from the analysis of LAGEOS-1/-2 and Etalon-1/-2 SLR data. BKG uses the Utopia (CSR Texas) software for this analysis. The satellite combinations are done at the observation level after fitting the orbits (BKG Solve). The provided products consist of a set of improved station coordinates, polar motion coordinates and LOD and their variance-covariance matrices in SINEX format according to the ILRS requirements. In addition, the weekly solution is accompanied by the sets of satellite's positions in time in the SP3c format.

To compare the performance of the SLR-ACs the combined solution from DGFI for week 071110 to 080927 is selected as a reference. Among others, the scale factor is chosen as an example (Figure 12-1).

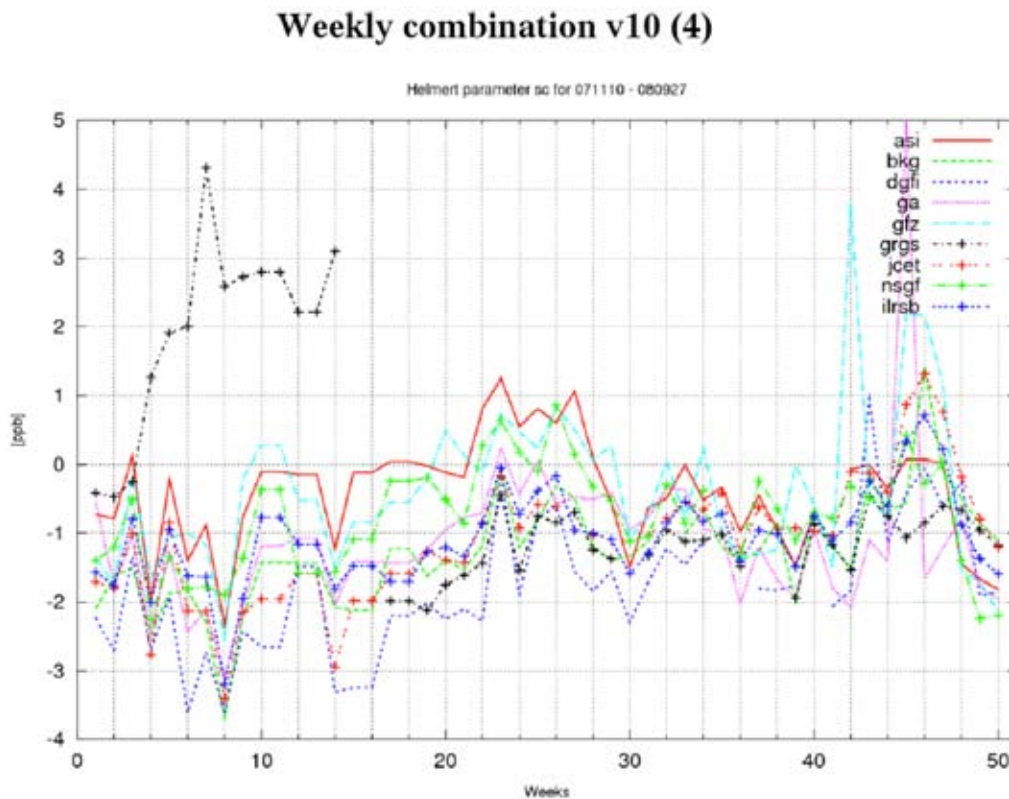

Figure 12-1. Weekly time series of the scale factor (ppb) provided by courtesy of DGFI Germany.

The BKG SLR AC supported development at AIUB to augment the Bernese software (BSW) with SLR capabilities for LAGEOS-1 and -2 data processing. Taking the SLR benchmark data set, solutions calculated with Utopia were compared with the solutions derived by the SLR component of the BSW. As a demonstration, the results of daily time series of orbit differences (AIUB versus BKG solution D) are presented in Figure 12-2. In the figure the difference between the two orbit solutions is shown in three components (light color). The darker line shows the mean value per revolution.

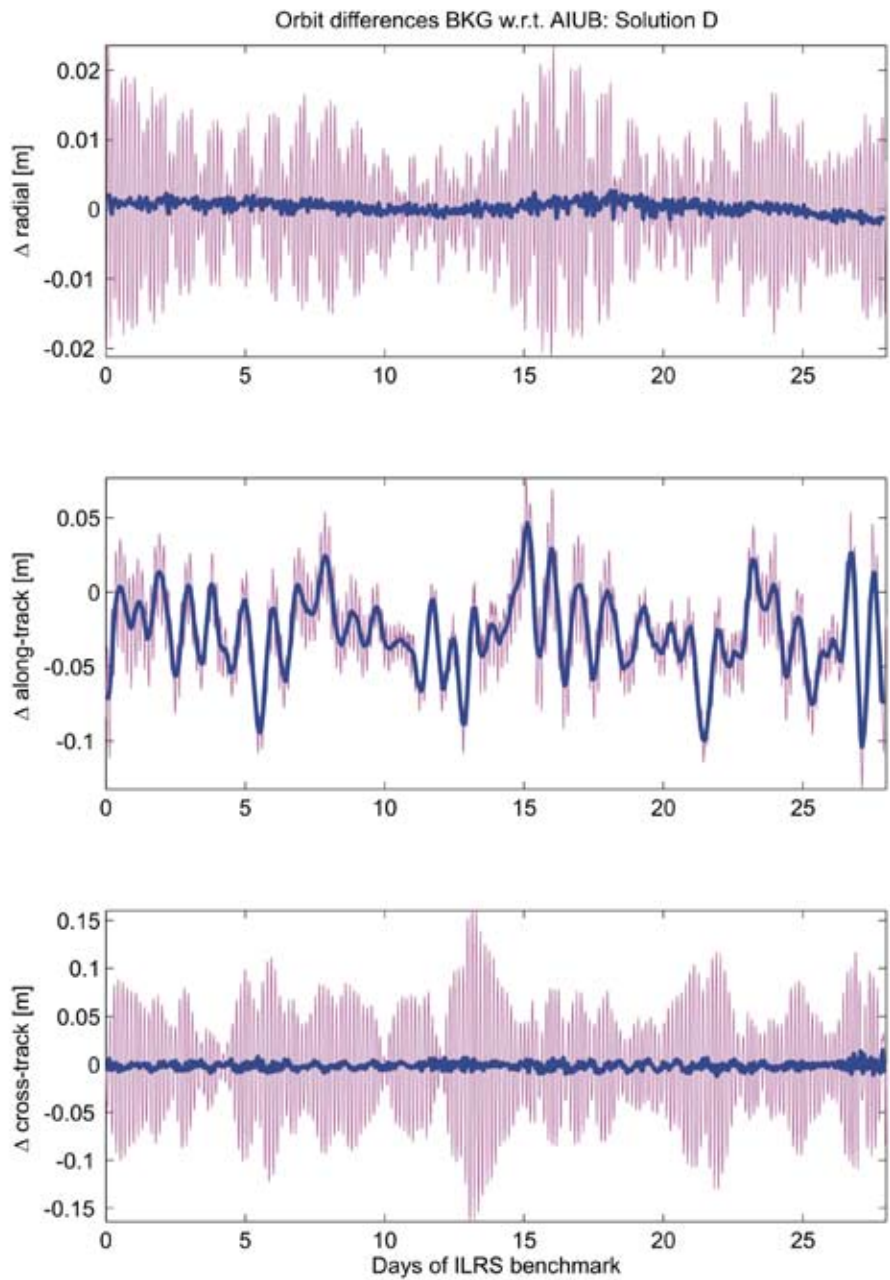

Figure 12-2. Daily time series of orbit differences (AIUB versus BKG solution D).

BKG must now develop the necessary scripts for the routine work to match the requirements and the environment of the SLR-BSW installation at BKG.

Contact

Dr. Bernd Richter
 Maria Mareyen
 BKG
 Richard Strauss-Allee 11
 D-60598 Frankfurt/Main 70
 GERMANY

Voice: 49-69-6333273
 E-mail: richter@iers.org
 E-mail: maria.mareyen@bkg.bund.de
 Fax: 49-69-6333425

Deutsches Geodätisches Forschungsinstitute (DGFI)

Horst Müller, Rainer Kelm, Detlef Angermann/DGFI

Introduction

As one of the ILRS Analysis Centers, DGFI was, besides the routine weekly processing of SLR station positions and Earth orientation parameters (EOP) and LAGEOS orbits, heavily involved in the processing required for the SLR time series for the new ITRF2008 reference frame. Furthermore, the backup solution for the combined SLR time series was computed at the DGFI ILRS Backup Combination Center. Other activities include the daily processing of a bias report for all SLR stations, using the LAGEOS and Etalon observations, and the qualification of new or returning SLR stations. The activities in the GGOS-D project concluded in 2008 with the final combined solution.

ILRS Analysis Center

As an ILRS Analysis Center, DGFI processes (on a weekly operational basis) SLR data to LAGEOS-1/2 and Etalon-1/2 and provides loosely constrained solutions (SINEX files) with station positions and Earth orientation parameters (X-pole, Y-pole and length of day) to the ILRS data centers at CDDIS and EDC. This processing is accomplished with the DGFI software package DOGS version 5.0. Additionally, orbits to these satellites are routinely processed and delivered.

During the automated processing, a number of quality checks are performed; one of these checks is the computation of pass-wise range and significant time biases. The weekly solutions and the results of the bias analysis sorted by satellite and week are available from the DGFI web server, <http://ilrsac.dgfi.badw.de/quality/index.html>. We provide the biases with respect to SLRF2005 coordinates for all stations and passes, but presently for the LAGEOS satellites only.

DGFI has agreed to maintain a list of station discontinuities and data handling, which will be distributed to all analysts through the data centers at CDDIS and EDC. Together with ASI and GRGS, DGFI performs the station qualification testing for new and returning tracking stations.

ILRS Combination Center

DGFI, as the official ILRS Backup Combination Center, uses the same procedures and constraints as the ILRS Primary Combination Center, which is performed by ASI, Italy. Both centers are obliged to compute, on a weekly basis, a combined SLR solution as an official product of the ILRS. The products are stored at the ILRS data centers. Both Combination Centers use software versions for automated processing.

The official weekly products are:

- Combined solution for station coordinates and EOP. DGFI delivers a SINEX file with a minimal constraints solution and with an unconstrained normal equation system.
- Combined solution for EOP aligned to SLRF2005. DGFI takes the EOP part of the above combined solution arguing that the minimal constraints solution is indirectly an alignment to SLRF2005, because the a priori coordinate values are taken from SLRF2005.

The combination of SP3c orbits is in a testing phase. When the AWG decides on the final product, combined LAGEOS-1/2 and Etalon-1/2 orbits, can be processed and provided to users.

More information on the analysis and Combination Center at DGFI is available from our homepage: <http://ilrsac.dgfi.badw.de/>.

Contribution to ITRF2008

After long discussions on ITRF2005, the generation of the next ITRF (ITRF2008) is now in process. DGFI is involved in the reprocessing. The reprocessed series of 15-days resp. weekly SINEX files with station positions and EOPs ranging from 1983 to 2008 were processed and sent to the data centers. The DGFI Combination Center combines all contributions from the eight Analysis Centers into the combined backup product, which will be used for validation. Figure 12-3 shows the transformation parameters from the similarity transformation between the new DGFI series for ITRF2008 and SLRF2005. There is a small drift, though data before 1993 are significantly worse than later periods. The figure shows a small offset and drift of scale and origin.

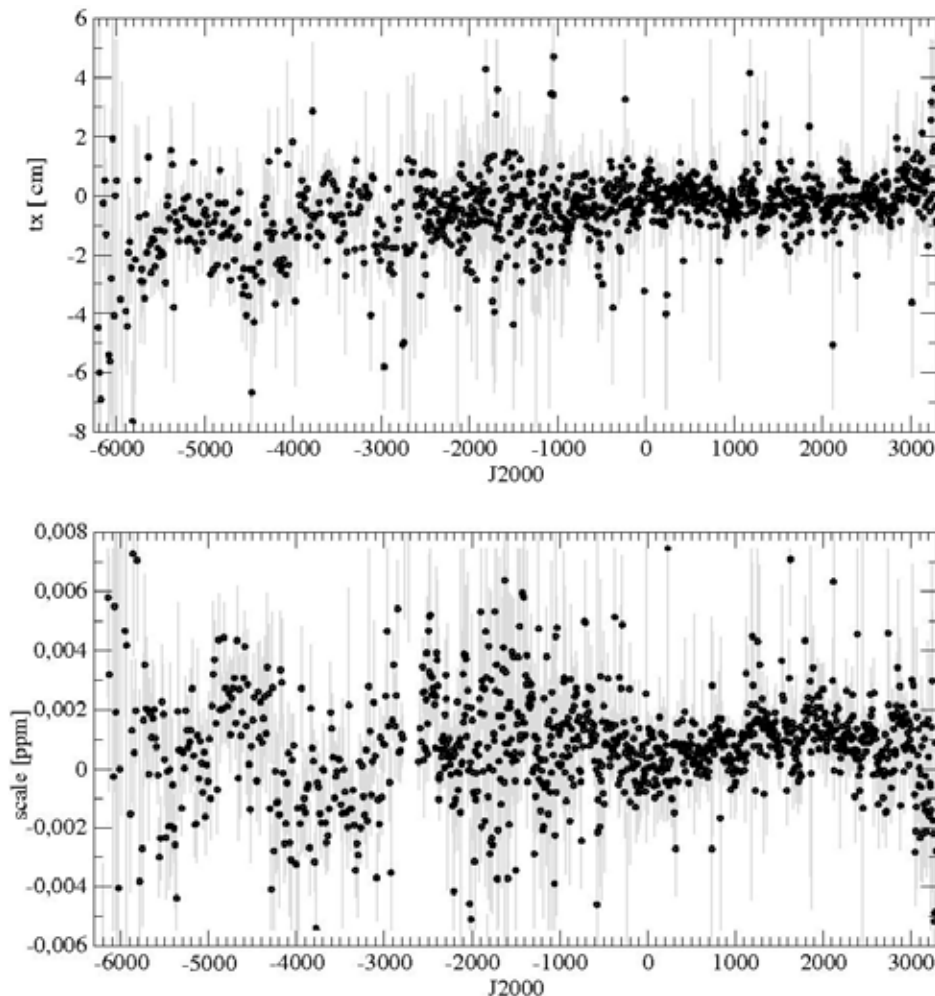

Figure 12-3a and -3b: Transformation parameters between DGFI solution and SLRF2005 with error bars.

Future Plans

Since the problems with the EOP interpolation and the LOD variations seem to be solved in the DGFI software, participation in the daily processing activity is foreseen. A still pending project is the routine processing of Starlette and Ajisai data, which should be resolved in 2009.

References

- Angermann D., Drewes H., Gerstl M., Krügel M., Meisel B.: ITRS Combination Centre at DGFI.. ITRS Combination Centre at DGFI, IERS Annual Report 2006, Bundesamt fuer Kartographie und Geodaesie, Frankfurt a.M. , 2008
- Angermann D., Müller H.: On the strength of SLR observations to realize the scale and origin of the terrestrial reference frame. IAG Symposia, Vol.133,3-9, Springer 2009.
- Angermann D., Drewes H., Gerstl M., Krügel M., Meisel B.: DGFI combination methodology for ITRF2005 computation, Proceedings of the IAG Symposium Geodetic Reference Frames GRF 2006 Munich, Springer, 2009, in press.
- Krügel, M, Angermann, D., Drewes, H., Gerstl, M., Meisel, B., Tesmer, V., Thaller, D.: GGOS-D Reference Frame Computations. GEOTECHNOLOGIEN Science Report, No. 11, ISSN 1619-7399, 2007a.
- Müller H., Angermann D.: Some Aspects Concerning the SLR Part of ITRF2005. In: Luck J., Moore Ch., Wilson P. (Hrsg.): Proceedings of the 15th International Workshop on Laser Ranging, EOS Space Systems PTY Limited, Canberra, 2008
- Müller H.: Analysis of Multi-Wavelength SLR Tracking Using Precise Orbits. In: Luck J., Moore Ch., Wilson P. (Hrsg.): Proceedings of the 15th International Workshop on Laser Ranging, EOS Space Systems PTY Limited, Canberra, 2008

Contact

Horst Müller	E-mail: mueller@dgfi.badw.de
Deutsches Geodätisches Forschungsinstitute	Voice: +49-89-23031-1277
Alfons-Goppel-Straße 11	Fax: +49-89-23031-1240
D-80539 München	
GERMANY	

Geoscience Australia (GA)

Ramesh Govind/Geoscience Australia

Introduction

Geoscience Australia (GA) was accepted as an ILRS Analysis Center in April 2007 after successfully completing and fulfilling all the benchmark requirements. During the period 2007-2008, focus has been on the weekly ILRS SINEX submissions and contribution to the ITRF2008. These results have been reported by the AWG Combination Centers. The GA Analysis Center routinely processes LAGEOS-1/-2, Etalon-1/-2, Stella, Starlette, GIOVE-A and GLONASS data for satellite orbit determination, station coordinates, Earth Orientation Parameters, station performance monitoring and developing a long-term time series of the low-degree and order spherical harmonic coefficients of the Earth's gravity field.

Facilities/Systems

The GA processing system uses NASA's GEODYN and SOLVE set of programs for orbit determination, geodetic parameter estimation, and combination solutions. A suite of programs has been developed in-house for analysis, re-formatting, and producing SINEX files.

Analysis Activities during 2007-2008

- Weekly solutions consisting of LAGEOS-1, LAGEOS-2, Etalon-1 and Etalon-2 data for the ILRS weekly product.
- As a contribution to the definition of the ITRF2008, weekly SINEX solutions were provided for the period 1983-2008, as per the requirements of the ILRS AWG.
- Stella and Starlette data for the period beginning 1996 through the end of 2008 were processed to study the contribution of these satellites to the definition of the ITRF. This work was reported at the 2007 Fall AGU in San Francisco (see below).
- In terms of GNSS, the potential for SLR observations to contribute to the definition of the ITRF and determination of other geodetic products (such as EOPs), the following SLR data were processed and the preliminary results were reported at the International GNSS Symposium in Sydney, 2007 (see Table 12-1 below).

Table 12-1. SLR Data from GNSS Satellites Processed for Geodetic Products

Satellite	Start Date	End Date
GLONASS -80	991024	020224
GLONASS -84	010701	050828
GLONASS -86	020303	021229
GLONASS -87	020303	070128
GLONASS -89	030323	070429
GLONASS -95	050904	070527
GLONASS -99	070121	070520
GIOVE-A	060528	071230

- SLR data to the Jason-1 and Envisat satellites were used to quality check their DORIS-determined orbits and to also compare the satellite orbits determined from the two observation types. These results were routinely presented at the International DORIS Service (IDS) AWG meetings. The Jason-1 and Envisat SLR data processed for this study are shown below:

Table 12-2. SLR (and DORIS) Data Processed for Orbit Comparison Studies

Satellite	Start Date	End Date
Jason-1	020120	080817
Envisat	020616	081231

Current Activities

Since the completion of the ITRF2008 submissions, focus is now on:

- Evaluating the potential contribution of SLR GNSS data to ILRS geodetic products
- Evaluating the contribution of Starlette and Stella to the ITRF definition
- Continuing quality checks of DORIS orbit products using SLR observations for Jason-1, Jason-2, and Envisat.

Related Publications

During the period 2007-2008 the following presentations were made:

Govind, R., F.G. Lemoine, N. Zelensky, S. Luthcke: "Evaluation the effect of atmospheric gravity and annual gravity field variation on LAGEOS orbits", ILRS Fall Workshop, Grasse, September 2007.

Govind, R., F.G. Lemoine, Z. Altamimi, K. Le Bail, D. Chin: "The contribution of Starlette/Stella SLR to Terrestrial Reference Frame definition, American Geophysical Union Fall Meeting, December 2007.

Govind, R. "The value of SLR observations to GNSS: The potential for Terrestrial Reference Frame Definition", International GNSS Symposium, Sydney, December 2007.

Contact

Dr. Ramesh Govind
Senior Research Scientist, Earth Monitoring Group
Geoscience Australia
PO Box 378, Canberra, ACT 2601
AUSTRALIA

Voice: 61 2 624 99033
Fax: 61 2 624 99929
E-mail: Ramesh.Govind@ga.gov.au

Helmholtz Centre Potsdam GeoForschungsZentrum German Research Centre for Geosciences (GFZ)

Rolf König, Franz-Heinrich Massmann, Sergei Rudenko, Krzysztof Słopek, Helmut Storr, Margarita Vei/GFZ

Activities in Support of the ILRS

Submission of orbit predictions for CHAMP, GRACE-A and -B and TerraSAR-X

For CHAMP, orbit predictions were updated three times per day prior to September 1, 2007, afterwards four times per day. For GRACE the update frequency was twice per day. Since its launch on June 15, 2007, TerraSAR-X orbit predictions are also produced. The update frequency for this satellite depends on the availability of the on-board data and has been twice per day in most cases so far.

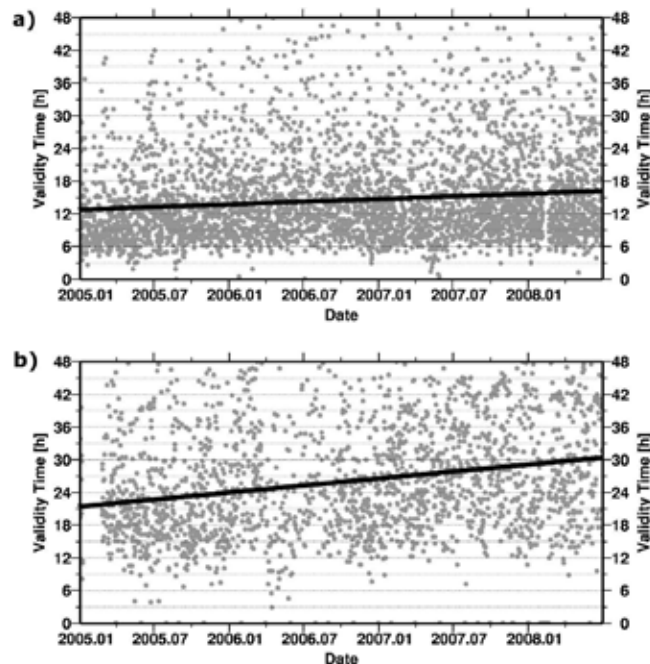

Figure 12-4. Validity times for all GFZ orbit predictions since 2005 for a) CHAMP and b) GRACE-A.

The accuracy of the orbit predictions is continuously monitored in order to allow for daylight ranging for what we assume is an error margin of 10 ms in time bias. Due to decreasing orbital altitudes and increasing solar activity, a faster degradation of the orbit prediction accuracy can be expected. The degradation can be avoided by enhancing the orbit prediction update frequency presumably if new input data become available to allow an update. For this reason GFZ operates the polar satellite receiving station at Ny-Ålesund (Spitzbergen), which enables download of the on-board data of the missions mentioned above nearly once per revolution, i.e., approximately every 1.5 hours. Figure 12-4 shows the validity time for all orbit predictions generated for CHAMP and GRACE-A since January 2005. The validity time is defined as the time in the predicted part of the orbit in which the time bias stays below 10 ms. The analysis shows that the majority of the orbit predictions is valid for more than six hours for CHAMP and for more than 12 hours for GRACE. These results justify the update frequency adopted thus far. The analysis also shows a trend towards increased validity times, which might be due to the concurrent low solar activity period.

GFZ's orbit prediction products consist of IRVs with drag functions, SAO elements, two-line elements, and the CPF format. The generation of IRVs with drag functions and SAO elements was terminated in December 2008. The orbit prediction generation system experienced no major downtimes and therefore has an operational readiness of nearly 100%.

Production of position and Earth orientation parameters from LAGEOS-1 and -2 analyses

GFZ continued its ILRS analysis center activities concerning the Pos+EOP project. Loosely constrained station position estimates with weekly resolution and Earth orientation parameters (polar motion and length-of-day) with daily resolution from LAGEOS analyses were submitted each week with three days latency in the form of SINEX files within the full reporting period. Since February 17, 2008, GFZ is additionally providing similar solutions on a daily basis with a one-day latency.

In support of the ITRF2008 development, historical LAGEOS data from 1983 up to the present were processed and supplied to the ILRS combination centers.

Production of LAGEOS-1 and -2 orbits in SP3 format

Since December 2, 2008, GFZ has delivered orbit solutions for LAGEOS-1 and -2 to the ILRS data centers. These orbit solutions correspond to the weekly Pos+EOP product and are provided in the SP3 orbit format.

Other Activities Involving SLR Data

- Regular computation of ERS-2 preliminary and precise orbits using SLR observations under ESA contract.
- New precise, consistent EIGEN-GRACE04S orbits of the radar altimetry satellites ERS-1, TOPE Poseidon, and ERS-2 with recent models.
- Monitoring of CHAMP, GRACE, and TerraSAR-X operational POD
- Generation of dedicated CHAMP, GRACE, LAGEOS, and general purpose satellite-only gravity field models and combined gravity field models from satellite and surface gravity data: the EIGEN series.
- Generation of an SLR reference frame solution for a rigorous combination with other space-geodetic solutions under common, up-to-date standards within the GGOS-D project
- Combined adjustment of GPS and Low Earth Orbiting (LEO) satellites on the observation level with GPS, SLR and mission-specific observations for reference frame and gravity field resolution (integrated approach).

Future Plans

- Adopt CRD format for observation data
- Processing and analysis of historical LAGEOS tracking data from 1976 to 1982
- Processing of LAGEOS long arcs
- Generation of Pos+EOP QC reports
- Consistent reprocessing of radar altimetry satellite orbits in ITRF2008 using up-to-date models
- Rigorous combination of space-geodetic data on the observation level for geodynamic applications

Contact

Dr. Rolf Koenig
GeoForschungsZentrum Potsdam (GFZ)
Dep. 1: Geodesy and Remote Sensing
c/o DLR Oberpfaffenhofen
D-82234 Wessling
GERMANY

Voice: 49-8153-28-1353
Fax: 49-8153-28-1735
E-mail: rolf.koenig@gfz-potsdam.de

Groupe de Recherche en Geodesie Spatiale (GRGS)

Florent Deleflie/OCA/GRGS, David Coulot/IGN

The staff of the GRGS ILRS Analysis Center are: Dr Pierre Exertier, Dr. Florent Deleflie, Dr Pascal Bonnefond, Olivier Laurain, Dominique Feraudy, and Dr. Bertrand de Saint Jean.

Operational Activities

1. ILRS weekly products: solution sent to ILRS data centers on a weekly basis. SINEX files contain EOP, station coordinates. Based on LAGEOS-1 and -2 orbital arcs (Etalon-1 and -2 currently being tested).
2. ILRS daily products: solution sent to ILRS data centers on a daily basis. SINEX files contain EOP, station coordinates.
3. Planned developments: solutions based on Etalon-1 and -2 orbits, as well. Optimization of the combination between different dynamical configurations, time series of degree 2 gravity field coefficients, on an operational basis.
4. References: EGU 2009, EGU 2008, COSPAR 2008, SF2A 2008, SF2A 2007

Analysis/Reanalysis Activities

1. Analysis/reanalysis for ILRS: comparison between the so-called “GRGS v11 solution” and “GRGS v20 solution”, over the period 1993-present. Reanalysis of historic data (before 1993) under investigation.
2. Analysis for GRGS (combination center): GRGS-OCA is in charge of a complete reanalysis of SLR data (2005-present), for all geodetic satellites (especially LAGEOS-1 and -2, but other satellites as well, Starlette and Stella in particular), with a force model accounting for all loading effects. GRGS aims at providing a global solution for EOP, and station coordinates, thanks to a combination of individual solutions based on SLR, GNSS, VLBI, or DORIS data.
3. Daily analysis of T2L2 (Time Transfer by Laser Link) data.
4. Other activities: orbit determination and validation for various satellites: Jason-1, Jason-2, GPS-35, GPS-36, GIOVE-A, GIOVE-B.
5. Planned developments: time series of gravity field coefficients, on an operational point of view (degree 2 to degree 5), on a weekly basis.

Methodological Activities:

1. Methodological activities concerning orbit modeling: empirical forces modeling, non-gravitational forces modeling (LAGEOS-1 and -2), correlation with gravity field and EOP coefficients.
2. Methodological activities concerning time and range bias: optimization of the de-correlation of the parameters.
3. Methodological activities concerning statistics and estimation methods: optimization of the combination between different dynamical configurations, comparisons of results obtained from merely “geometrical” approaches, and merely “dynamical” approaches.
4. Planned developments: time transfer equations.

Fields of Interest

- Earth rotation, and its gravity field
- Station coordinates, range bias, terrestrial reference frame
- Fundamental physics
- Orbit determination and validation
- Motion of the Moon

Contact

Dr. Pierre Exertier

Voice: +33-(0)4 39 40 53 82

E-mail: Pierre.Exertier@obs-azur.fr

Florent Deleflie

Voice: +33-(0)4 93 40 53 81

E-mail: florent.deleflie@obs-azur.fr

OCA/GEMINI

Fax: +33-(0)4 93 40 53 33

Avenue Nicolas Copernic

06130 Grasse

FRANCE

Joint Center for Earth Systems Technology/Goddard Space Flight Center (JCET/GSFC)

Erricos C. Pavlis, Magdalena Kuzmich-Cieslak, and Peter Hinkey/JCET

Introduction

The JCET/GSFC AC participated in all AWG-related ILRS activities during the period 2007-08. In addition this AC presently coordinates the overall activities of the AWG. Since April 2001, we routinely analyze LAGEOS-1 and -2, and Etalon-1 and -2 data for the generation of the weekly operational products. In 2007 we investigated the development of an additional daily operational product to address the needs of IERS' NEOS service for as "fresh" EOP estimates as possible. After a test-period of some months, the procedure was presented to the AWG and it was decided to run a pilot project that would give the opportunity to other ACs to contribute to this product and give the CCs the opportunity to merge them into a combined product with similar attributes to the weekly one. This was formally installed as a pilot project in late 2008 with initially three ACs contributing to the product. Upon evaluation of the results by NEOS, the AWG will decide whether to continue or abandon this effort. The JCET-developed web-based process to generate a summary, visualizations and statistical analysis product of the official weekly ILRS products has been further improved, extended to include the contributions from the additional ACs that joined the AWG during this period (GA and GRGS). The web pages can be accessed from: http://geodesy.jcet.umbc.edu/ILRS_QCQA. Figure 12-5 shows the initial page.

The screenshot shows the front page of the JCET website. At the top, there is a blue banner with the text "EVALUATION, VALIDATION AND MONITORING OF ILRS COMBINATION PRODUCTS" flanked by the JCET and NASA logos. Below this, there are two main sections: "OPERATIONAL SERIES QC/QA (1993 - Present)" and "SUMMARY REPORT BY AC (CURRENT WEEK)". The summary report is presented as a table with two columns, ILRS4 and ILRS8, listing various ACs. Below the table is a section for "PREVIOUS WEEKS REPORT". At the bottom, there is a footer with the UMBC logo, the text "RELEASE v4.2", and the International Laser Ranging Service logo.

SUMMARY REPORT BY AC (CURRENT WEEK)	
ILRS4	ILRS8
AST	AST
BKG	BKG
DGFI	DGFI
GA	GA
GRZ	GRZ
GRGS	GRGS
JCET	JCET
NSGF	NSGF
COMBINATION	COMBINATION

Figure 12-5. Front page of JCET's "Evaluation, Validation and Monitoring of ILRS combination products".

The entire process has been revisited during 2008 and a new one has been designed which will be far more flexible, allowing the user to select the period of time and the type of products to be plotted, a choice of the plot scale and access to the data used to generate the plots. This new system is expected to be functional for a test-period in 2009 and soon after released for public access.

Since JCET is also coordinating the AWG, it is also conducting the software benchmarking process for all new candidate ACs for the ILRS. During 2008 we had initial submissions from ESA/ESOC and an existing AC (BKG) since they are in the process of exchanging the currently used software (Utopia) with a new version of the Bernese software that was extended to handle laser range data.

The collaborative work with the Italian groups at the University of Lecce and University of Rome (“La Sapienza”), resulted in the approval of the LARES mission by ASI and initiation of the construction of the satellite. In support of the LARES mission design group, JCET prepared several targeted studies tailored to address questions associated with the optimization of the spacecraft design.

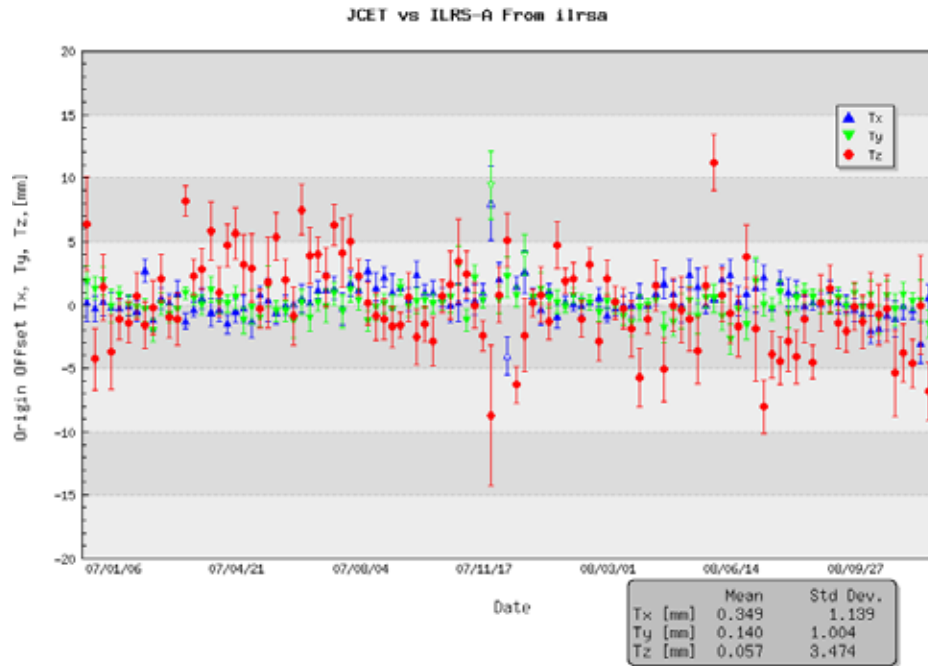

Figure 12-6. Time series of origin shifts of the JCET contribution with respect to the ILRS combination product for 2007 - 2008.

Background

The activities of JCET are primarily focused on the analysis of SLR data from LAGEOS -1/-2 and Etalon-1/-2, as required for the generation of ILRS products. The products supported are weekly station positions (and velocities for the multi-year solutions) and the Earth Orientation Parameters, x_p , y_p , and LOD at daily intervals. In anticipation of a future ILRS product, we also form on a weekly basis a cumulative solution that is based on the entire set of analyzed data from 1993 to present. The weekly sets of normal equations are also used to derive a weekly resolution series of “geocenter” offsets from the adopted origin of the reference frame, defined by the multi-year solution.

Facilities/Systems

The operational products are now developed on a Linux cluster with eight processors. Over a period of six months in 2008, the processes were run in parallel on the Sun workstation and the Linux cluster to ensure that the processes were delivering identical results. Once the consistency was assured, the old line of production was switched off and the new line replaced it.

Current Activities

The generation of weekly solutions as a contribution to the IERS/ITRF and the monitoring of episodic and seasonal variations in the definition of the geocenter with respect to the origin of the conventional reference frame continues in a routine manner (Figure 12-6).



Figure 12-7. Time series of scale of the JCET weekly contribution with respect to the ILRS combination product for 2007-2008. The 0.141 ppb standard deviation corresponds to less than 1 mm in length.

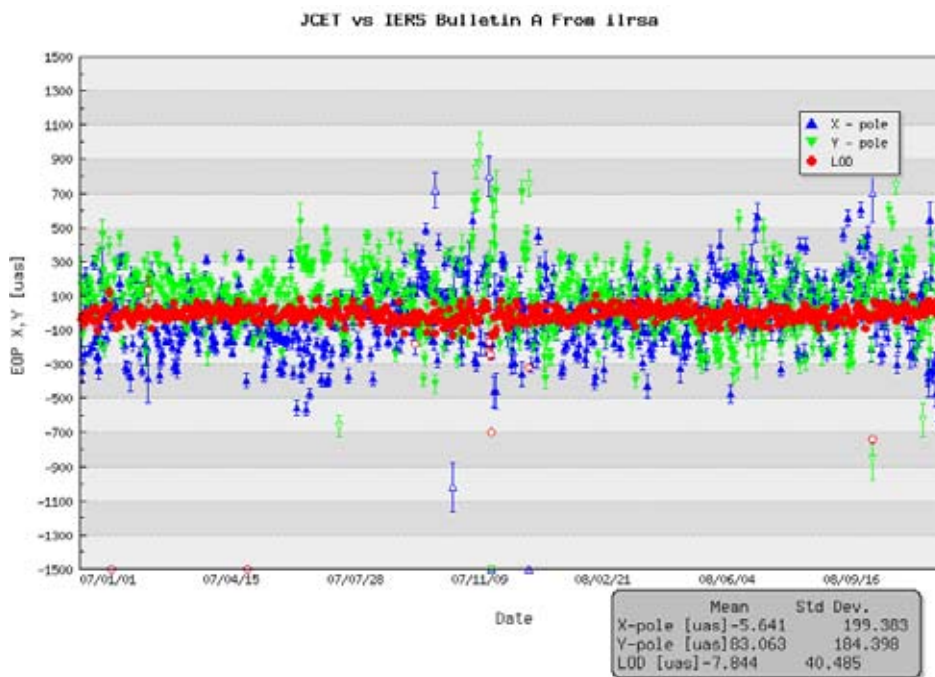

Figure 12-8. Time series of JCET EOP daily offsets from IERS' Bulletin A, for 2007 – 2008.

Figure 12-7 shows the evolution of the weekly scale estimates from JCET over the reporting period, indicating a very small bias with respect to the SLRF2005 a priori frame, and a stability of less than 1 mm (0.141 ppb). The differences of the daily JCET EOP estimates from the Bulletin A series are shown in Figure 12-8. The statistics of these differences are only 10% larger than the corresponding statistics or the final combined ILRS product, indicating a high level of consistency with that product.

Following the evaluation of the ILRS contribution to ITRF2005, the AWG decided to undertake a closer look at station biases and to adopt an approach that would lead to a uniform treatment of biases by all ACs. Using long-term solutions base on all of the analyzed years since 1983, biases were estimated with respect to the frame that

resulted from this solution. These are far more stable than those obtained from weekly solutions which are strongly correlated to the station height. Examples of such estimates are shown in Figure 12-9 for some of the stations with characteristic problems.

The need to recover biases at the data analysis stage is increasing, especially as we advance in the background modeling efforts and errors previously hidden in the noise, are now becoming the dominant ones. As the modeling progresses, smaller systematic errors, as the various measurement biases, are now becoming the leading errors. Through such investigations we attempt to identify biases at or below the 10 mm level, which are impossible to detect with engineering tests. When correlated with events at the station, then these biases are adopted and applied a priori, leading to by far more stable solutions.

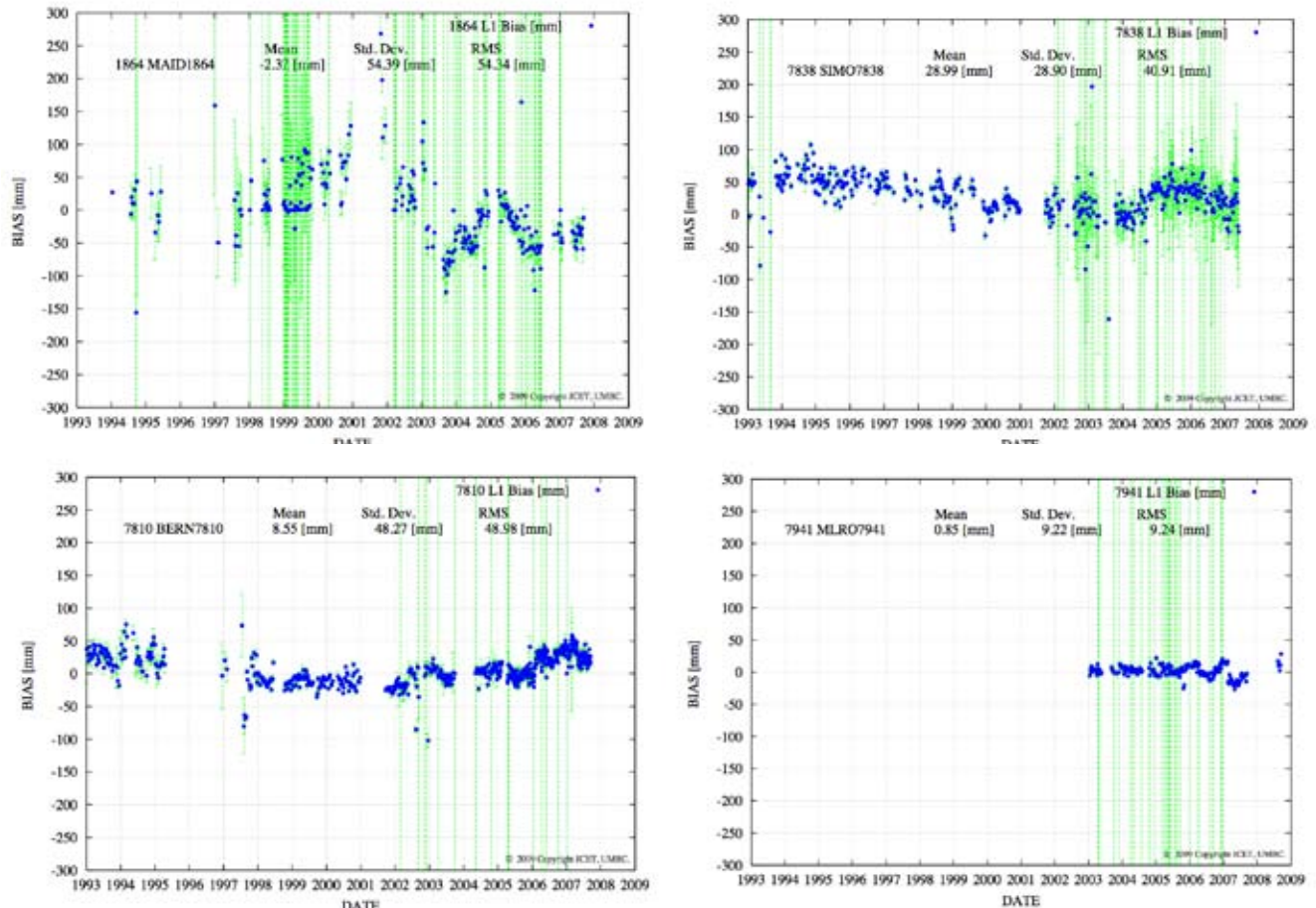

Figures 12-9a-d. Time series of weekly biases from a JCET long-term solution based on LAGEOS data from 1993 to 2008.

Finally, one of the additions to JCET's ILRS data analysis related contributions during this period is the development of a quality control and assessment solution on a daily basis. The biases of all ILRS sites with respect to the two LAGEOS and Etalon are monitored and reported via a standardized email message. This contributes to the ILRS combined bias estimate and the quarterly report cards, starting with the last quarter of 2007: http://ilrs.gsfc.nasa.gov/stations/site_info/global_report_cards/perf_2008q4_wLLR.html.

JCET has been selected by NASA as the US PI for the Italian Space Agency (ASI) mission LARES, to launch a cannoball satellite in a ~ 1500 km circular orbit with an inclination of $\sim 71^\circ.5$, in order to improve the results of the joint relativistic experiment and measurement of the GR-predicted Lense-Thirring effect or "frame-dragging". The team that submitted the successful proposal includes GSFC, USNO and University of Texas at Austin co-investigators. The proposed work involves studies for the improved modeling of forces acting on the satellite,

improved geometric correction models for the accurate description of the satellite's "center-of-mass" offset, thermal force modeling and spin-axis orientation and rate estimation.

Future Plans

ILRS-related activities will continue, with emphasis on the near-real-time generation of weekly products and their dissemination via the web. We have extended our analysis to years prior to 1993, with the generation of 15-day SINEX files beginning with the launch of LAGEOS in May 1976. Emphasis is now placed on the completion of simulation studies that will provide guidelines in the design of the future geodetic network to support the accuracy goals of the GGOS program of IAG. GGOS is focused on addressing very tough problems, e.g., Mean Sea Level monitoring, imposing stringent accuracy requirements in the definition of the underlying reference frame (less than 1 mm accuracy in the origin definition at epoch, and less than 0.1 mm/y stability).

References, Publications, Presentations (2007-2008)

- Ciufolini, I. A. Paolozzi, S. Dell'Agello, I. Peroni, F. Graziani, G. Sindoni, C. Paris, C. Vendittozzi, P. Ialongo, C. Cerruti, A. Lucantoni, A. Boni, C. Cantone, G. Delle Monache, A. Franceschi, T. Napolitano, N. Intaglietta, M. Martini, M. Garattini, G. Bellettini, R. Tauraso, L. Caputo, F. Passeggio, F. Longobardo, E. C. Pavlis, R. Matzner, D. P. Rubincam, D. Currie, V. J. Slabinski, D. A. Arnold, "The Design of LARES: a Satellite for Testing General Relativity", paper IAC-07- B4.2.07 in proceedings of 58th International Astronautical Congress, Hyderabad, India, 24 - 28 September, 2007.
- Ciufolini, I., E.C. Pavlis, et al., (2009), "Gravitomagnetism and its Measurement with Laser Ranging to the LAGEOS satellites and GRACE Earth Gravity Models", in *Lectures at the Wheeler school on relativity*, 2006 Erice Summer School Lecture series, (in press).
- Hulley, G. C. and E. C. Pavlis, A ray-tracing technique for improving Satellite Laser Ranging atmospheric delay corrections, including the effects of horizontal refractivity gradients, *J. Geophys. Res.*, 112, B06417, doi:10.1029/2006JB004834, 2007.
- Hulley, G. C., E. C. Pavlis and V. B. Mendes (2007), Model validation for improved atmospheric refraction modeling for Satellite Laser Ranging, *Dynamic Planet - Monitoring and Understanding a Dynamic Planet with Geodetic and Oceanographic Tools*, (Chapter 119), Tregoning, P., Rizos, C., (eds.), IAG Symposia 130, ISBN: 978-3-540-49349-5, pp. 844-852, 2007.
- Hulley, G., and E. C. Pavlis, (2007), Improvement of Current Refraction Modeling in Satellite Laser Ranging (SLR) by Ray Tracing through Meteorological Data, 15th Int. Laser Workshop, John Luck (ed.), pp. 345-350, Geosciences Australia, Canberra.
- Kopeikin, S.M., E. C. Pavlis, D. E. Pavlis, V.A. Brumberg, A. Escapa, J. Getino, A. Gusev, J. Müller, W.-T. Ni, N. Petrova, (2008), Prospects in the orbital and rotational dynamics of the Moon with the advent of sub-centimeter lunar laser ranging, *J. Adv. Space Res.*, doi:10.1016/j.asr.2008.02.014.
- Pavlis, E. C., (2007), The Global SLR Network and the origin and scale of the TRF in the GGOS era, 15th Int. Laser Workshop, John Luck (ed.), pp. 159-166, Geosciences Australia, Canberra.
- Pavlis, E. C., V. Mendes and G. Hulley, (2007), Tropospheric Model: Optical Techniques, *IERS Conventions 2003*, G. Petit and B. Luzum eds., IERS Technical 32, (Chapter 9, pp. 1-7), online version: <http://tai.bipm.org/iers/conv2003/conv2003.html>, Paris, France, 2007.
- Pavlis, E. C., I. Ciufolini, and R. König (2007), Recent Results from SLR Experiments in Fundamental Physics, 15th Int. Laser Workshop, John Luck (ed.), pp. 69-78, Geosciences Australia, Canberra.
- Pavlis, E. C., (2007), SLR-based evaluation and validation studies of candidate ITRF2005 products, 15th Int. Laser Workshop, John Luck (ed.), pp. 173-179, Geosciences Australia, Canberra.
- Pavlis, E. C., V. Mendes and G. Hulley, (2008), Tropospheric Model: Optical Techniques, in *IERS Conventions 2003*, G. Petit and B. Luzum eds., IERS Technical 32, online version: <http://tai.bipm.org/iers/convupdt/convupdt.html>, Paris, France, 2008.

- Pearlman, M., Z. Altamimi, N. Beck, R. Forsberg, W. Gurtner, S. Kenyon, D. Behrend, F.G. Lemoine, C. Ma, C.E. Noll, E.C. Pavlis, Z. Malkin, A.W. Moore, F.H. Webb, R.E. Neilan, J.C. Ries, M. Rothacher, and P. Willis, GGOS Working Group on Networks, Communication, and Infrastructure, Dynamic Planet - Monitoring and Understanding a Dynamic Planet with Geodetic and Oceanographic Tools. Rizos, C., Tregoning, P. (Eds.) , IAG Symposia 130,ISBN: 978-3-540- 49349-5, 2007.
- Pearlman, M., C. Noll, J. McGarry, W. Gurtner, E. Pavlis, The International Laser Ranging Service, AOGS 2007, *Adv. Geosciences*, v. 13, pp. 129-153, World Scientific.
- Willis, P., J.C. Ries, N.P. Zelensky, L. Soudarin, H. Fagard, E. C. Pavlis, and F.G. Lemoine, (2009), "DPOD2005 : An extension of ITRF2005 for Precise Orbit Determination", *Advances in Space Res.*, 44 pp.535–544, Elsevier, The Netherlands, doi:10.1016/j.asr.2009.04.018.

Contact

Dr. Erricos C. Pavlis
Goddard Earth Sciences and Technology Center,
(GEST/UMBC)
University of Maryland, Baltimore County
1000 Hilltop Circle
Acad IV Wing A 114E
Baltimore, MD 21250
USA

Voice: (410) 455-5832
Fax: (410) 455-5868
E-mail: epavlis@UMBC.edu

Natural Environment Research Council (NERC) Space Geodesy Facility (NSGF)

Graham Appleby, Philip Gibbs, Matthew Wilkinson, and Vicki Smith/NERC

Introduction

The primary work of the NSGF Analysis Center has been an ongoing global laser ranging re-analysis effort as a contribution to the ILRS combination that will be part of the next realization of the International Terrestrial Reference Frame, ITRF2008. Several attempts have been made by the AC to mitigate systematic range effects of up to 15mm in both the Herstmonceux data itself and potentially for other stations that have used similar time-of-flight counters; various generations of these corrections have meant that all the ACs have been asked on several occasions to repeat the analysis work to produce for the early time-frame (1983-1992) 15-day and for the more modern (1993-date) 7-day coordinate solutions. Finally, it was decided within the ILRS Analysis Working Group that a mixture of engineering and empirical range corrections best fitted the ITRF efforts, and final analyses are being carried out.

Furthermore, the availability of laser ranging, GPS, and absolute gravity data from the Herstmonceux site, plus the ability to analyze each data set, has opened up some exciting opportunities for research, especially into vertical signals at the site. Supporting data in the form of high-time-resolution water table depth measurements are also available continuously from 1996 to date, and have been used in some recent investigations, as outlined below. The AC continues to supply back-up daily satellite orbital predictions in CPF form, and to carry out daily web-based global QC of the four primary geodetic satellites LAGEOS and Etalon.

Possible Systematic Bias in SGF Laser Range Data

The NSGF AC has been re-analyzing global laser ranging data to the geodetic satellites from 1983 to present, for later combination by the primary and backup Combination Centers into the ILRS contribution to the forthcoming ITRF2008. During the course of this work, coordinated by the ILRS Analysis Working Group, it became apparent that either there was a dramatic decrease in the height of the 7840 Herstmonceux station of some 15mm from early 2007, or that some systematic error had entered the laser ranging data from that date. This was the time that the new, highly accurate event timer was introduced operationally into the ranging system, and the extensive tests did not reveal any problems, certainly of the magnitude experienced with the Stanford counters used from 1993 to 2007. Reports were also received from other users of the SGF data, especially those doing precise orbital determination of the altimeter missions (Lemoine, F, private communication, 2008) that a jump had occurred in the laser ranges to those satellites as well. To test whether there was a data problem or a site-motion or stability problem, an analysis of the vertical motion of the site from 2006 to 2008 using GPS, SLR and AG data was carried out, and the results reported in a presentation at the 16th International Workshop on Laser Ranging in Poznan, Poland, in October 2008 (Appleby, Luceri, and Gibbs, 2008) and in a poster at the AGU (Appleby et al., 2008), in December. Neither the GPS nor the AG results supported the anomalous vertical motion of the site implied by the laser data, and indeed the conclusion is that it is the data prior to the installation of the event timer that is in error.

This work led the group to question its detailed evaluation of the effects of non-linear behavior of the Stanford interval counters that have been used at the station since 1993. It had been discovered previously that the non-linear behavior can corrupt both target-board calibration results and satellite ranging results at levels of up to 10mm each. These results were presented at the 15th International Laser Ranging Workshop in Canberra (Gibbs and Appleby, 2006) and at an invited presentation at the EGU 2007 (Appleby, Otsubo, and Gibbs, 2007). This careful evaluation led to the release to the community of a table of corrections for the SGF data and estimates of the likely errors in the data from a number of other ILRS stations that use or have used Stanford counters. However, more recent work, presented by Luceri et al. (EGU, 2009) and based on range-bias solutions and analyses, implied that the corrections in this table are in some instances themselves in error by up to 8mm; the most likely cause is inherent, high-frequency, non-linearity of the counters, always a limitation of the calibration process. In those instances, which coincide with subtle system changes at the station, empirical range corrections are clearly superior and have

to be used. This is unfortunate since some long-term, small, geodetic signals, such as GIA effects, will likely be lost from the data set. It is also clear that SGF's attempts to improve the data from other stations that used Stanford counters will also be of less value than previously considered.

Height Signals from SLR, GPS and AG

Analysis of residual height signals at Herstmonceux has begun, using all three on-site techniques, in collaboration between SGF and University College London (Prof. M. Ziebart) and the UK Proudman Oceanographic Laboratory (POL, Dr. S. Williams). The space geodetic height time series for Herstmonceux (SLR and GPS) for the period from late 2006 until late 2008 has been used to remove vertical signals from the gravimeter results. A comparison of this height-corrected gravity time series with variations in the local water table shows very little agreement and a simple, Bouguer-based computation of the magnitude of the water table effect overestimates the observed gravity amplitude by some five times. A paper on this initial work was presented by V. Smith at an IAG symposium on Gravity, Geoid and Earth Observation, and is now in press in a Springer series (Appleby et al., 2009).

Future work will involve a thorough investigation into the local geology including the use of soil-moisture probes to better quantify hydrological effects on local gravity. It is very important to measure the dry and wet densities of the local compacted clay, as errors in the values assumed in the previous investigation will directly impact the computed gravity variation. In addition, particular areas of interest for further work are an evaluation of the treatment of atmospheric attraction on the test-mass of the gravimeter and models of site atmospheric and hydrological loading. This effort should improve the value of gravimetry in the interpretation of the SGF space geodetic results and have wider implications for similar multi-technique space geodetic facilities.

Daily QC of LAGEOS and Etalon Range Observations

On a daily basis, 7-day orbital solutions are carried out using global ILRS observations of the four LAGEOS and Etalon geodetic satellites. The station coordinates and velocities are held fixed at their ITRF2005_SLR values and corrections are made to the daily a-priori, IERS and rapid service predicted Earth orientation parameters. Post-fit residuals for each station for all four satellites are displayed in graphical form on the SGF website, along with residual mean and precision (RMS) values. The plots allow a rapid identification of outlier normal points at the level of a few cm, as well as any overall mean systematic bias with respect to the assumed station coordinates.

For any passes observed simultaneously by more than two "core" stations a further short-arc solution is carried out, based on a scheme developed many years ago by Andrew Sinclair to monitor tectonic motion by computing inter-station baselines (Sinclair and Appleby, 1993). The scheme solves for empirical, constrained, along-track, across-track and radial corrections to the fitted 7-day orbit that are valid only during the times of each of the simultaneous tracking periods. The residuals with respect to these "short-arc" orbits for all stations that tracked these arcs are also displayed in graphical form daily on the website, and reveal more subtle, perhaps 10mm-level, data or station-coordinate problems.

The SGF website recently has been relocated and is now hosted at Herstmonceux at <http://sgf.rgo.ac.uk/>.

References

- Appleby, G.M., Smith, V., Wilkinson, M, Williams, S., Ziebart, M., 2009. "Comparison of height anomalies determined from SLR, absolute gravimetry and GPS with high frequency borehole data at Herstmonceux", in press, IAG Springer.
- Appleby, G.M., Smith, V., Wilkinson, M, Williams, S., Ziebart, M., 2008, "Height signals determined from SLR, absolute gravity and GPS observations at the Space Geodesy Facility, Herstmonceux, UK", poster presentation, AGU, San Francisco, December 2008.

- Appleby, G.M., Wilkinson, M., Luceri, V., Gibbs, P., Smith, V. 2009. "Attempts to separate apparent observational range bias from true geodetic signals", in press in *Proceedings of the 16th International Laser Ranging Workshop*, Poznan, Poland, October 2008.
- Appleby, G.M., Otsubo, T., Gibbs, P., 2007. "Further Improvements in Understanding Subtle Systematic Effects in Laser Ranging Observations", (abstract and presentation), *Geophysical Research Abstracts*, Vol 9, EGU General Assembly 2007.
- Gibbs, P., Appleby, G.M. and Potter, C.B., 2006. "A reassessment of laser ranging accuracy at SGF Herstmonceux, UK", in *Proceedings of the 15th International Laser Ranging Workshop*, Canberra, Australia, October 2006.
- Greaves M., Bingley R.M., Baker D.F., Appleby G., 2008. "National report of Great Britain, 2008". Report on the Symposium of the IAG Subcommittee for the European Reference Frame (EUREF), June 2008.
- Luceri, V., Sciarretta, C., Appleby, G.M., Bianco, G., 2009. "Measurement Bias Effects in the ILRS Product for the ITRF", (abstract and presentation), *Geophysical Research Abstracts*, Vol 11, EGU General Assembly 2009.
- Sinclair, A.T., Appleby, G.M., 1993. "A Short-Arc Method for Determination of Station Coordinates and Baselines Applied to the Mediterranean Area", *Contributions of Space Geodesy in Geodynamics: Crustal Dynamics*, AGU Geodynamics Series, V.23, pp. 389-396, Edited by D.E. Smith and D.L. Turcotte, 1993.

Contact

Graham Appleby
ITE Monks Wood
Abbots Ripton
Huntingdon, Cambridgeshire PE17 2LS
UNITED KINGDOM

Voice: 44-0-1487-772477
Fax: 44-0-1487-773467
E-mail: graham.appleby@nerc.ac.uk

ILRS ASSOCIATE ANALYSIS CENTER REPORTS

Associate Analysis Centers are organizations that produce special products, such as satellite predictions, time bias information, precise orbits for special-purpose satellites, station coordinates and velocities within a certain geographic region, or scientific data products of a mission-specific nature.

Center for Orbit Determination in Europe (CODE)

Daniela Thaller/Astronomical Institute, University of Bern, Switzerland

Introduction

The Center for Orbit Determination in Europe (CODE) is a joint venture of the Astronomical Institute of the University of Bern (AIUB), the Federal Office of Topography in Switzerland (Swisstopo), the Federal Agency of Cartography and Geodesy of Germany (BKG), and the Institute of Astronomical and Physical Geodesy of the Technische Universität München (IAPG/TUM). The activities as an Associate Analysis Center of the ILRS are located at AIUB. CODE performs two types of activities for the ILRS:

- Production of predictions for the GNSS satellites tracked by the ILRS;
- Generation of daily SLR quick-look reports.

Predictions for GNSS Satellites

CODE also acts as an Analysis Center of the International GNSS Service (IGS). For nearly six years, a rigorous combined analysis of the GPS and GLONASS microwave measurements is carried out not only for the final but also for the rapid and ultra-rapid product line of the IGS. The ILRS network provides routine tracking of the two GPS satellites equipped with retro-reflectors (i.e., GPS-35 and GPS-36) and three of the GLONASS satellites. From the combined GPS/GLONASS rapid orbits – derived at CODE from the microwave data – orbit predictions for these five GNSS satellites are provided to the ILRS in the Consolidated Prediction Format (CPF).

The selection of the three GLONASS satellites for SLR tracking changed throughout the last years: On May 28, 2008, GLONASS-95 was replaced by GLONASS-109. Just recently (April 3, 2009), GLONASS-99 was replaced by GLONASS-115 in our predictions. Therefore, at the moment, CODE provides SLR predictions for GPS-35, GPS-36, GLONASS-102, GLONASS-109, and GLONASS-115.

CODE Quick-Look Reports

CODE provides daily SLR-GNSS quick-look reports for SLR observations of the GNSS satellites over the last six days. The residuals are computed with respect to the SLRF2005 station coordinates, and the GNSS microwave-derived orbits and Earth rotation parameters (ERPs) determined at CODE for the IGS. The GNSS orbits of the last two days result from the rapid GNSS analysis, whereas the orbits of the earlier four days are taken from CODE's final GNSS analysis.

The summary of the quick-look analysis is divided by station, by satellite, and by day. It contains the mean residual, the rms and the number of observations. The quick-look summary is distributed daily via e-mail and is available from the ILRS web site.

Scientific Analysis

SLR is a very important tool to validate the quality of the orbits derived from microwave data and to detect deficiencies in the orbit modeling. A set of very significant results in this field of research was recently compiled in the PhD thesis of Claudia Flohrer (Flohrer 2008). A continuation of this validation work will be given in a poster presentation at the EGU 2009 (Thaller et al. 2009).

References

Flohrer, C. (2008): Mutual validation of satellite-geodetic techniques and its impact on GNSS orbit modeling. PhD Thesis. Geodätisch-geophysikalische Arbeiten in der Schweiz, Vol. 75.
Thaller, D., A. Steinbach, and R. Dach (2009): Combined analysis of GNSS and SLR observations for the GIOVE satellites. Geophysical Research Abstracts, Vol. 11, EGU2009-2671, EGU General Assembly 2009.

Contact

Dr. Daniela Thaller
Astronomical Institute, University of Bern
Sidlerstrasse 5
CH-3012 Bern
SWITZERLAND

Voice: +41-31-631-3802
Fax: +41-31-631-3869
E-mail: thaller@aiub.unibe.ch

The University of Texas Center for Space Research (CSR)

John Ries, Minkang Cheng, Richard Eanes / UTCSR

Introduction

In addition to contributing to the SLR data acquisition through its operations at the McDonald Laser Ranging Station (MLRS), the Center for Space Research (CSR) routinely analyzes the tracking data for several geodetic satellites in support of data quality assessment, station coordinate testing, monitoring long-wavelength geopotential variations (including geocenter motions), and reference frame evaluation.

Reference Frame

An important practical consideration for precision orbit determination (POD) is the set of coordinates (position and velocity), and associated range biases, adopted when processing the laser ranging tracking. Routine orbit determination and verification for missions such as the ocean and ice altimeter missions (TOPEX/Poseidon, Jason-1, Jason-2, and ICESat) and gravity missions (CHAMP and GRACE) rely on very precise coordinates and bias knowledge, since these missions operate at the 1-2-cm radial orbit accuracy level. To provide these missions with a consistent and validated set of precise coordinates, CSR has modified and augmented the current coordinate set based on ITRF2005 to correct for problems in that solution (usually due to bias issues not accommodated in the original solution), add stations not included in ITRF2005 and update coordinates based on improved bias knowledge. The result is a recommendation for a set of coordinates and range biases that are consistent with ITRF2005 and have been validated with the tracking of five precise geodetic targets (LAGEOS-1, LAGEOS-2, Starlette, Stella, and Ajisai) over the interval of 1993-2009. This set of tracking station coordinates, LPOD2005 (<ftp://ftp.csr.utexas.edu/pub/jason/models/coords/LPOD2005.doc>), is intended for laser ranging to be the equivalent of DPOD2005 for DORIS (see <http://www.ipgp.fr/~willis/DPOD2005.htm>).

Geocenter Motion

We have continued to monitor the variations in the geocenter location, since this represents both possible systematic drifts in the terrestrial frame as well as seasonal mass transport within the Earth system that is not well monitored by other techniques. The GRACE mission, for example, is able only to accurately determine the temporal mass changes for degrees 2 and above. The geocenter variations (equivalent to the degree-1 geopotential harmonics) contain an important mass variation signal. In Figure 12-10, we show a recent estimate of the geocenter motion obtained from SLR tracking of LAGEOS-1/LAGEOS-2 since the beginning of the LAGEOS-2 mission in late 1992. In this analysis, the network is held fixed to ITRF2005, and the geocenter offset is estimated every 60 days (constant over the 60-day arcs). A bias is also estimated for each station/arc with an a priori constraint of 5 mm. The estimation of the bias is especially important for the Z variation; if biases are not estimated, the annual Z variation can exceed 5 mm. We have previously noted a significant drift in such analyses relative to ITRF2000, especially in Z, but this analysis indicates only small drifts relative to ITRF2005; less than 0.1 mm/y for X and Y, and ~0.3 mm/y for Z. The bias is under 1 mm for X and Y, but ~5 mm for Z.

Table 12-3 (following page) shows that the annual variations determined from this series agree very well with a number of other estimates in both amplitude and phase. The estimated uncertainty is based on the scatter of the geodetic estimates, including this study. The scatter of the geophysical models was larger in X and Y but the same for Z.

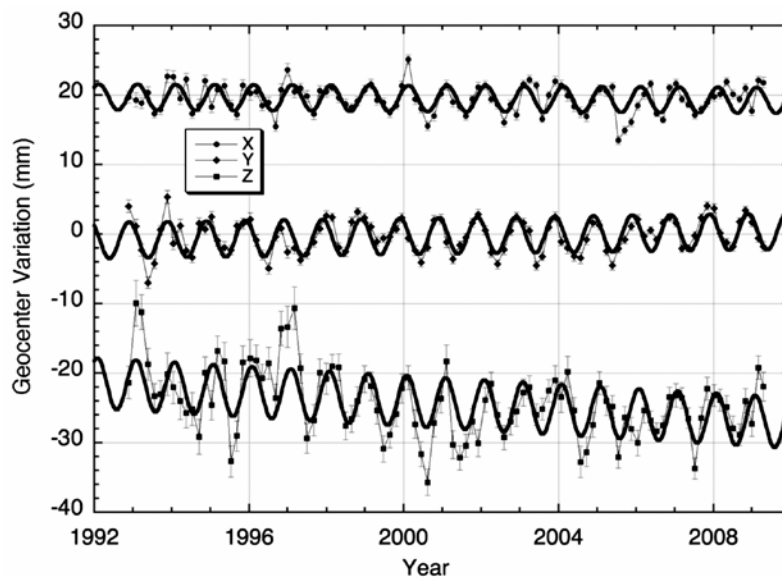

Figure 12-10. Geocenter variations estimated every 60 days from LAGEOS-1/LAGEOS-2. X and Z have had 20 mm added and subtracted, respectively. The fit curve is a bias, slope and annual term. The addition of a semi-annual term does not significantly improve the correlation.

Table 12-3. Estimates of annual amplitude (mm) and phase (deg) from this analysis compared to the mean of five studies based on SLR or combinations of GPS, GRACE and ocean bottom pressure models, and the mean of five geophysical model predictions. The amplitude and phase are defined by $amp \cdot \cos(\omega t - phase)$, where t is years past January 1 and ω is the annual frequency.

Case	X (amp)	X (phase)	Y (amp)	Y (phase)	Z (amp)	Z (phase)
L1/L2 (this study)	1.9	44	2.6	325	3.7	31
Mean of geodetic estimates	2.0	44	2.5	322	2.9	40
Mean of model estimates	2.4	34	2.2	329	3.2	34
Estimated uncertainty	0.4	7	0.4	6	0.7	14

We have obtained a new determination of the long-term variations in J2, shown in Figure 12-11. It is clear that J2 has undergone significant variations during the past 33 years. The estimate of the secular rate is significantly affected by the interannual variations. In particular, two large fluctuations in J2 are correlated with the strong ENSO events of 1986-1991 and 1996-2002, and it appears that a new cycle has started around 2007.

Testing General Relativity

In an independent analysis of the SLR tracking to LAGEOS-1 and LAGEOS-2 using several models resulting from the GRACE gravity mission, we have been able to confirm the effect of the Lense-Thirring precession predicted by General Relativity to better than 15%, consistent with previously published results. The uncertainties in J4 and J6 still dominate the current error budget, but improvements in the mean gravity field model from the GRACE mission should make even more precise tests possible in the future.

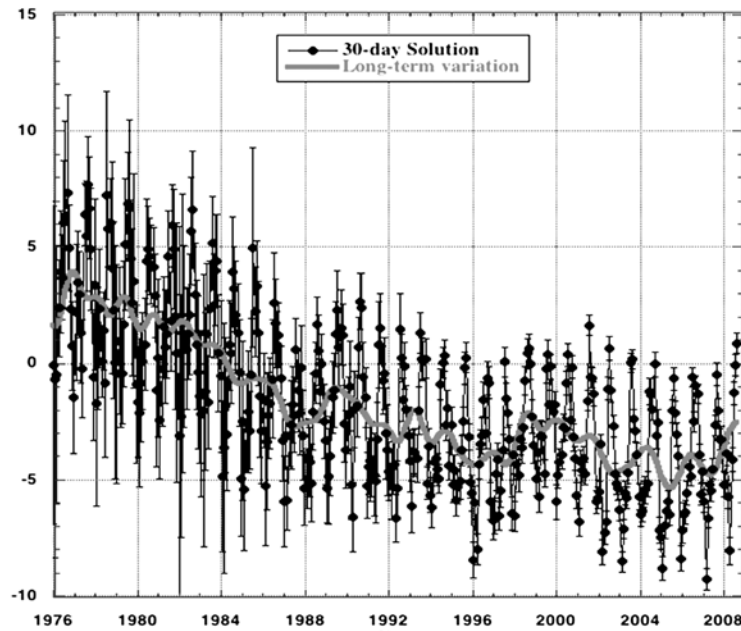

Figure 12-11. Monthly estimates and the long-term variation of J_2 determined from up to seven geodetic satellites.

References

- Cheng M. K. and B. D. Tapley, Variations in J_2 from GRACE and 33-years of SLR data, paper: PSD1-0042-08, the 37th COSPAR Scientific Assembly, 13-20 July 2008, Montreal, Canada.
- Cheng M. K. and B. D. Tapley, A 33-Year Time History of the Earth Dynamic Oblateness Changes from SLR Data, 16th International Laser Ranging Workshop, Poznan, Poland, 15-19 October 2008.
- Cheng M. K. and B. D. Tapley, Recent variation in the Earth Dynamic Oblateness, J_2 , from SLR and GRACE data, GRACE Science Team Meeting, December 12-13, San Francisco, 2008, and 2008 AGU Fall meeting: Eos Trans. AGU, 89(53), Fall Meet. Suppl., Abstract G33A-0673.
- Ries, J. C., Satellite Laser Ranging and the Terrestrial Reference Frame; Principal Sources of Uncertainty in the Determination of the Scale, Geophysical Research Abstracts, Vol. 9, 10809, 2007, EGU General Assembly, Vienna, Austria, April 15-20, 2007 [SRef-ID: 1607-7962/gra/EGU2007-A-10809].
- Ries, J. C., R. J. Eanes, M. M. Watkins, Confirming the Frame-Dragging Effect with Satellite Laser Ranging, 16th International Laser Ranging Workshop, Poznan, Poland, 15-19 October 2008.
- Ries, J. C., LPOD2005: A Practical Realization of ITRF2005 for SLR-based POD, presented at Ocean Surface Topography Science Team Meeting, Nice, France, 10-12 November 2008 (<http://www.avisioceanobs.com/fileadmin/documents/OSTST/2008/oral/ries.pdf>).
- Ries, J. C., M. Cheng, S. Bettadpur, D. P. Chambers, SLR-Determined Low-Degree Geopotential Harmonics and their use with GRACE Data Products, Eos Trans. AGU, 89(53), Fall Meet. Suppl., Abstract G13AC-0632, December 2008.

Contacts

Dr. John C. Ries
Dr. Minkang Cheng
Dr. Peter Shelus
Prof. Bob Schutz
Center for Space Research
The University of Texas at Austin
Mail Code R1000
Austin, TX 78712
USA

E-mail: ries@csr.utexas.edu
E-mail: cheng@csr.utexas.edu
E-mail: shelus@csr.utexas.edu
E-mail: schutz@csr.utexas.edu
Fax: 01-512-471-3570
Web: <http://www.csr.utexas.edu>

Delft University of Technology (DUT)

Nacho Andrés de la Fuente, Eelco Doornbos, Ron Noomen/DUT

Introduction

The Delft Institute for Earth Observation and Space Systems (DEOS) at Delft University of Technology has been active in the field of SLR analysis since about 1980. The activities relevant for the reporting period include (i) LAGEOS orbit modeling and (ii) ERS-2 and Envisat orbit computations.

LAGEOS Orbit Modeling

A main application of the SLR observations on LAGEOS-1 and -2 is their use for crustal dynamics investigations and reference frame definitions. Here, it is extremely important to model the orbit of the LAGEOS spacecraft as well as possible. An element of the dynamic model for these vehicles, which has gained significance during the last few years is the modeling of thermal forces (the net pressure force exerted by the photons emitted by the satellite surface). In the reporting period and the years directly before, DEOS has developed a number of essential elements for the characterization and understanding of such forces: LOSSAM (LAGEOS Spin Axis Model) and LOSTHERM (LAGEOS Thermal Model). LOSSAM gives (predictions of) the instantaneous rotation (direction and magnitude) of the two LAGEOS satellites, with uncertainties typically in the order of about 5 deg for attitude and about 5 sec (depending on the moment of evaluation) for the spin period. The finite-element model LOSTHERM describes the thermal behavior of 2133 different elements of each satellite; by evaluating the temperature and resulting force (emitted photon momentum) of each surface element and integrating these, it is possible to derive values for the net thermal acceleration that acts on the spacecraft. The LOSTHERM results show a consistent temperature behavior of the various LAGEOS elements, and yield accelerations that are in line with the results obtained from orbital computations. In addition, an accurate modeling of the accelerations due to the interaction with the magnetic field and collisions with charged particle has also been developed.

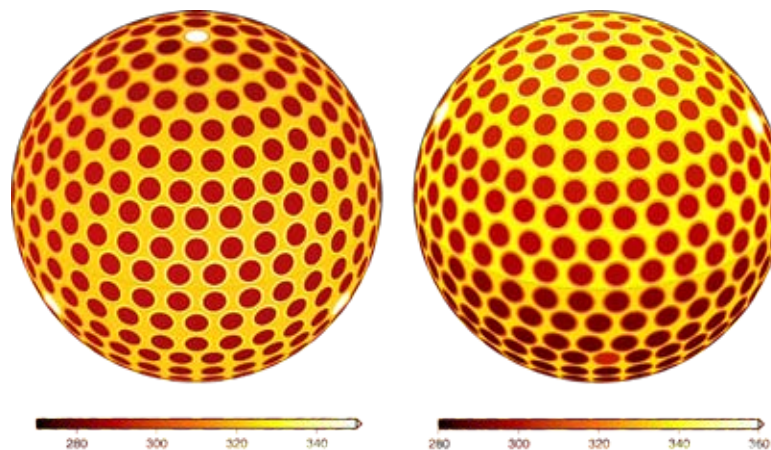

Figure 12-12: an illustration of the temperature distribution over the surface elements of LAGEOS-1 (left) and LAGEOS-2 (right).

ERS-2 and Envisat precise orbit determination

The orbit determination of ERS-2 and Envisat has had a low priority in recent years, because of lack of manpower. Instead, work has been performed on investigations of satellite drag using other data sources. At the moment, DEOS is gearing up for a re-analysis of the complete ERS-1 and ERS-2 data set, with updated models for the network coordinates, measurement modeling and satellite dynamics, including improvements to the density and drag modeling.

Publications

Andrés de la Fuente, N., Enhanced modeling of LAGEOS non-gravitational perturbations, PhD report, 321 pp, Delft University of Technology, September 7, 2007

Contacts

Ron Noomen

E-mail: R.Noomen@tudelft.nl

José Ignacio Andrés

E-mail: nacho@deos.tudelft.nl

Eelco Doornbos

E-mail: e.n.doornbos@tudelft.nl

Delft University of Technology

Faculty of Aerospace Engineering

Kluyverweg 1

2629 HS Delft

THE NETHERLANDS

European Space Operation Centre (ESOC)

Michiel Otten, John Dow, Rene Zandbergen, Dirk Kuijper, Tim Springer/ESA/ESOC

Introduction

One of the tasks of the Navigation Support Office of the European Space Operation Centre (ESOC) is to provide high-precision orbit data for ESA's Earth Observation missions (ERS-2, Envisat). This orbit data are used, among other applications, to assist in the calibration and validation of the altimeter instrument and data processing techniques. To achieve this task, SLR data for ERS-2 and Envisat are processed on a daily basis, together with other instrument data for the two missions. Furthermore, we are generating precise orbit solutions for the GIOVE-A spacecraft since continuous reliable SLR tracking became available in June 2006 and for GIOVE-B since May 2008.

In addition to this activity, ESOC is the prime prediction center responsible for the delivery of predictions for the ERS-2, Envisat, GOCE, GIOVE-A, and GIOVE-B spacecraft. The predictions are disseminated to all SLR stations using the standard ILRS CPF prediction format and exchange mechanisms. These activities include predictions over orbit maintenance maneuvers for ERS-2, Envisat and GOCE, which are planned by and executed at ESOC.

Facilities/Systems

All orbit solutions and related products are generated using a common software package (NAPEOS) and are generated automatically. The orbit solutions for ERS-2 and Envisat consist of 7-day arcs with varying timeliness of availability, depending on the mission. For ERS-2 the solution is generated with a delay of six days to allow collection of all SLR tracking data. For Envisat the final precise orbit solution has a typical delay of around 4-6 weeks depending on when the DORIS Doppler data become available.

Current Activities

For ERS-2, since the failure of the last onboard tape recorder in August 2003, the SLR tracking data have become the sole means to generate routinely precise orbit solutions. This process has been running very reliably for the last five years thanks to the consistent tracking support provided by the ILRS community.

For Envisat, two different precise orbit solutions are generated. The first solution is a fast-delivery solution, which uses the SLR data together with the fast-delivery altimetry data. This solution is used to support the operational activities of Envisat and is also used to monitor the long-term performance of the Envisat altimeter. The second (and final) precise solution for Envisat is generated when the DORIS Doppler data for Envisat become available and is used to monitor the SLR and DORIS Doppler data performance.

For GIOVE-A and GIOVE-B, precise orbit solutions based on SLR tracking data have been generated since June 2006 and May 2008 respectively. These precise orbits have also been the basis for the orbit predictions as provided to the ILRS community. The precise orbit solutions have been used in studies inside the Galileo project to validate the orbit solutions based on the microwave data, to validate the microwave data, and to study the behavior of the GIOVE-A and GIOVE-B onboard clocks.

In 2008 the ESOC Navigation Support Office reprocessed all the historic IGS data from 1994 to 2008. We have analyzed the quality of the reprocessed GPS satellite orbits by using all the ILRS SLR tracking data of the two GPS satellites for the period from 1995 to 2009. The resulting residuals are given in Figure 12-13. below. This is the first time that a homogeneous time series for the GPS satellite orbits was available and was used in an SLR analysis. The results are very encouraging, except for the eclipse phases of the satellites (the dark circle in the middle of the figure). The agreement between the SLR observations and the GPS orbits is at the 20 mm level. Both the mean and the residual RMS are at the 20 mm level (if we ignore the eclipsing part).

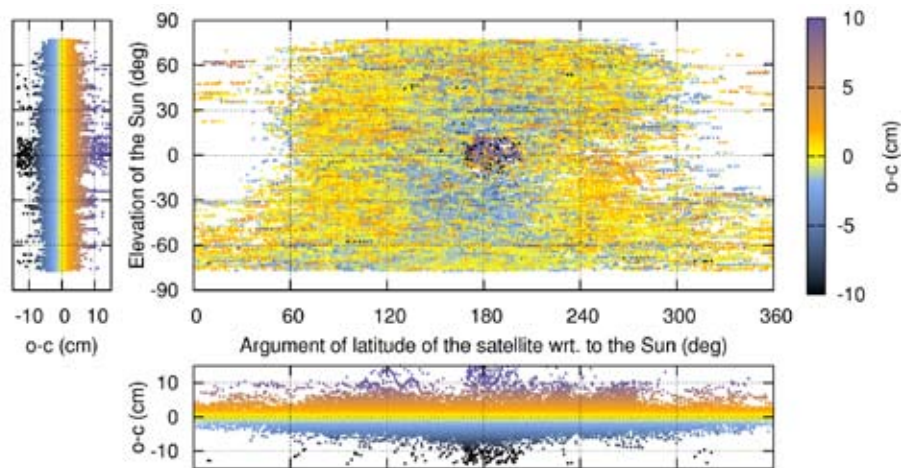

Figure 12-13. The residuals of the SLR observations from the GPS satellites over the time frame of 1995 to 2008 using the ESOC reprocessed orbits of the GPS satellites.

The ILRS data are extremely valuable since they provide a unique and fully independent quality check. This historic ILRS tracking data of the GNSS targets are of significant value for the IGS reprocessing efforts. Besides using the data to validate our reprocessing results it should be possible to include the data in the actual data processing and thus connect the SLR and GPS reference frame directly “in Space” and not (only) through Earth based on local site ties. The period from 1995 to 2008 yielded ~90,000 SLR observations of the GPS satellites and thus would contribute 90,000 local ties or more specifically “Space Ties”.

Future Plans

Besides the ongoing activities, the Navigation Support Office plans to process the SLR tracking data from Cryosat-2 where again the data will play an important role in the monitoring of ESOC’s operational and predicted solutions.

Furthermore, ESOC has also participated in the reprocessing of the ILRS data of the LAGEOS-1 and -2 and Etalon-1 and -2 satellites and is planning to become a full analysis center of the ILRS. However, the rather lengthy approval process for becoming an ILRS AC has kept us from contributing to the ILRS reprocessing results for the ITRF2008. Nevertheless, we hope to be able to contribute as a full AC to the ILRS in the near future.

Contacts

John Dow (Head of Navigation Support Office)
 ESA/ESOC, Robert-Bosch-Strasse 5
 D-64293 Darmstadt
 GERMANY

Voice: +49-6151.902272
 Fax: +49-6151-903129
 E-mail: John.Dow@esa.int

Rene Zandbergen (Navigation Support Office)
 ESA/ESOC, Robert-Bosch-Strasse 5
 D-64293 Darmstadt
 GERMANY

Voice: +49-6151-902236
 Fax: +49-6151-903129
 E-mail: Rene.Zandbergen@esa.int

Tim Springer
 ESA/ESOC, Robert-Bosch-Strasse 5
 D-64293 Darmstadt
 GERMANY

Voice: +49-6151-90-2029
 E-mail: Tim.Springer@esa.int

Forsvarets Forskningsinstitut (FFI)

Per Helge Andersen/FFI

Introduction

FFI has during the last 26 years developed a software package called GEOSAT for the combined analysis of VLBI, GNSS (GPS, Galileo, GLONASS), SLR, and other types of satellite tracking data (DORIS, PRARE and altimetry). The observations are combined at the observation level with a consistent model and consistent analysis strategies. With this procedure, the time-evolution of the common multi-technique parameters (for example EOP, geocenter, troposphere, or clock parameters) are treated consistently across the techniques. This is not the case when the techniques are combined “rigorously” at the normal equation level. The data processing is automated except for some manual editing of the SLR observations.

In the combined analysis of VLBI, GNSS, and SLR observations the data are processed in arcs of 24 hours defined by the duration of the VLBI session. The result of each analyzed arc is a state vector of estimated parameter corrections at the last epoch of observation and a Square Root Information Filter array (SRIF) containing parameter variances and correlations for the same epoch. The individual arc results are combined into a multi-year global solution using a Combined Square Root Information Filter and Smoother program called CSRIFS. With the CSRIFS program any parameter can either be treated as a constant or a stochastic parameter between the arcs. The estimation of multi-day stochastic parameters is possible and extensively used in the analyses.

Activities

After five years of development and validation a completely new version of the GEOSAT software (called GEOSAT_2010) is ready for routine processing of space geodesy observations and tracking data towards spacecrafts in the solar system. The new version of GEOSAT has several useful features:

- It can simultaneously combine data from virtually any number of VLBI, SLR, and GNSS instruments at a co-located site either observing simultaneously or in different time windows. All information will contribute to the estimation of the migration of an automatically selected master reference point at each station. Time series of eccentricity vectors will also be estimated: For GNSS the vector from the reference marker to the antenna phase center will behave as a step function where steps are introduced at epochs where instrumental changes (new antennas, installation or removal of a radome etc) have taken place. In practice the eccentricity vectors for GNSS will be estimated using a stochastic parameterization where close to zero noise are added except for the epochs of instrumental changes where a big amount of noise are added so that the values may jump to a new level. The same strategy is used to represent the motion of sites suffering from earthquakes. For VLBI and SLR the eccentricity vectors will usually be invariant in time and estimated as constants.
- The solved-for model parameters in combined processing of the VLBI+SLR+GNSS can either be instrument-dependent, technique-dependent, microwave-dependent, optical-dependent, or site-dependent. The switching between the different types is extremely simple. A simple application would be to, in a first run, treat the zenith wet delay parameters as instrument-dependent parameters which means that, for example, a station with two GPS receivers and one VLBI instrument will have three estimates of this parameter. If the results are consistent, these parameters can be estimated as a single parameter represented by a microwave-dependent parameter in a second run. The same can be tested for clock parameters for co-located clocks etc.

- New to this version of the software is ambiguity resolution of undifferenced GPS data. Due to a very precise a priori model the ambiguity resolution is performed using a priori residuals and not as part of a a posteriori filter solution which is the common procedure. Thus, no phase biases are estimated in the filter. Only resolved data are used in the analysis, which have reduced the number of GPS stations in the solution for each arc (24 h of data) from approximately 175 to typically 135. The actual station IDs involved in an arc changes in general from day to day so that many more GPS stations will be present in the global multi-year solution.
- Analysis of tracking data to spacecraft in deep space has been added. The software automatically detects the central body, if any (Earth or a body in the solar system), and accordingly performs the analysis either in a local geocentric frame of reference (if Earth is the central body) or in a solar system barycenter frame of reference. The contributing forces necessary to match the observation precision are automatically accounted for. It is, for example, in principle possible to calculate the trajectory of the spacecraft and the orbit and gravity field of the central body.
- For any technique, the delay due to the troposphere is determined with 3D raytracing (rescaled with actual pressure for SLR) using the European Center for Medium-range Weather Forecast Numerical Weather Model.

The status of the analysis as of May 2009 is as follows. After extensive testing a “close to optimal” mix of solve-for parameters, constraints and weighting has been found for the combined analysis. Among the estimated parameters are a GPS antenna phase center offset to be added to the satellite-dependent phase center offsets/variations tabulated by IGS, and time dependent estimates of the geocenter, C20, C22 and S22. So far, 1201 arcs have been processed at the combination level with this strategy. This is 63% of the days in the period October 1, 2002 through December 31, 2007. Several runs at the global multi-year level with these 1201 arcs have been performed with very interesting results.

The expected outcome will be new realizations of TRF, CRF, and EOP relying on consistent models and estimation strategies. As a by-product, a file of estimated eccentricity vectors will be produced. This type of analysis is along the lines of the ideas behind the GGOS project where geometry, gravity and Earth orientation are to be simultaneously and consistently determined.

Future Plans

We hope to include space-borne gravity (accelerometer, gradiometer, satellite-satellite range/Doppler, altimetry etc) in GEOSAT for a simultaneous analysis with VLBI, SLR and GPS. This extension will be made possible by a close collaboration between Statens Kartverk and FFI.

Contact

Dr. Per Helge Andersen
FFI, Division III
P.O. Box 25
N-2007 Kjeller
NORWAY

Voice: 47-63-807407
Fax: 47-63-807212
E-mail: per-helge.andersen@ffi.no

Main Astronomical Observatory of the National Academy of Sciences of Ukraine (GAOUA)

Olga Bolotina/Main Astronomical Observatory of the National Academy of Sciences of Ukraine

Introduction

The SLR Data Analysis Center of the Main Astronomical Observatory of the National Academy of Sciences of Ukraine (MAO NASU) was created in 1988. The center was accepted as an ILRS Associate Analysis Center (GAOUA AAC) in 1998. The primary interests of our SLR data analysis center are: software development, data processing of SLR observations, creation of an archive of SLR observations, and collaboration with the Ukrainian Branch of the World Data Center for Solar and Terrestrial Physics (UB WDC-B).

A collection of the observation data from all Ukrainian permanent SLR stations is kept in a local archive. The Kiev-Geodynamics software, developed by GAOUA, is used for SLR data analysis. Since 1989, we have calculated EOP, coordinates, and velocities of SLR stations. Detailed information about the GAOUA AAC is available on the Ukrainian Center of Determination of the Earth Orientation Parameters webpage, <http://mao.kiev.ua/EOP/>.

Scientific Results

The main scientific results during the period 2007-2008 are as follows. The stability of the network of the Ukrainian SLR stations (Simeiz, Katzively, Golosiiv-Kiev, and Lviv) was investigated through processing LAGEOS-1 and LAGEOS-2 observations from January 5, 1989 through November 11, 2004. The stability of the coordinate determinations for each station was estimated. The factors influencing this stability of the network are outlined below.

A new algorithm for parameter estimation with an arbitrary time interval was developed and programming was completed. The main principles for estimation of the parameters for the combined analysis of SLR, VLBI and GPS observations, as well as the parameter estimation algorithm with an arbitrary time interval, were described.

The stability of the positions of Ukrainian co-location stations Simeiz, Katzively, Golosiiv-Kiev, and Lviv was investigated. Our findings:

- Conclusions concerning the instability of the Simeiz-Katzively geodynamic test area have been made. Systematic errors were detected in ITRF2000 with incorrect determination of the velocities of VLBI, SLR and GPS reference points at the co-located (i.e., same DOMES number) Simeiz-Katzively site. A proposition to assign different DOMES numbers to these reference points was made to the ITRF combination center.
- High-precision coordinates of reference points, as well as the estimation of the local deformations during the period from 1997 to 2006 of the Golosiiv-Kiev geodynamic test area, were obtained. Conclusions about the existence of the tendencies relative to the local displacement of the reference points of the test area MAO NAS of Ukraine are made.

Determination of individual and combined ILRS, IVS, IGS, and IDS series the Earth Orientation Parameters has been investigated. Analysis and geophysical interpretation of the spectrum of polar motion time series were made.

Current Activities

- Monitoring of the stability of the Ukrainian SLR network
- Processing of all available LAGEOS-1 and LAGEOS-2 SLR observations
- Investigation of stability of the geodynamical test of area (co-location station)
- Combination of VLBI, SLR, and GPS observations
- EOP time series investigations
- Organization of regular SLR workshops “The activity of the SLR Network of Ukraine”
- Preparing and publishing “The Bulletin of the Ukrainian Center of the Earth Orientation Parameters” (since 2007)
- Collaboration with the UB WDC-B

Future Plans

- Developing the Kiev-Geodynamics ver. 6.0 software
- Operational analysis of the SLR observations

References

- Bizouard Ch. , Bolotina O., Bolotin S. Atmospheric and oceanic normal modes in polar motion, Proc. of the Journées 2008 “Systemes de Reference Spatio-Temporels”, Dresden, Germany, September, 22-24, 2008 (in press).
- Bolotina O.V., Samoilenko A.N., Bolotin S.L., Kozel V.L. Investigation of instability of points position of collocation station “Simeiz-Katzively”, Kinematics and Physics of Celestial Bodies. Vol. 24, No 5. pp 388-400. 2008.
- Bolotina O., Medvedskij M. Some results of investigation of the stability of the Ukrainian SLR stations, Kinematics and Physics of Celestial Bodies. Vol. 23, No 1. pp 11-17. 2007.
- Bolotina O., Bolotin S., Khoda O., Bizouard Ch. Combination of Different Space Geodetic Techniques: Algorithm of Parameters Estimation, Proc. of the Journées 2007 “Systemes de Reference Spatio-Temporels”, Paris, France, September, 17-19, pp 204-205. 2007.
- Bolotina O., Review of Ukrainian SLR network activity during 2005-2008, Bulletin of the Ukrainian Center of the Earth Orientation Parameters. No 3. pp 35-37. 2008.
- Bolotina O., Bolotin S., et al. UCEOP in UB WDC system, Bulletin of the Ukrainian Center of the Earth Orientation Parameters. No 3. pp 32-34. 2008.
- Bolotina O. Associate Analysis Center of SLR observation, Bulletin of the Ukrainian Center of the Earth Orientation Parameters. No 1. pp 80-81. 2008.
- Bolotina O., Ukrainian SLR network activity in 2007, Bulletin of the Ukrainian Center of the Earth Orientation Parameters. No 2. pp 32-33. 2007.
- Bolotina O., UCEOP archive of the SLR observations, Bulletin of the Ukrainian Center of the Earth Orientation Parameters. No 2. pp 34. 2007.
- Bolotina O., Medvedskij M. About stability of coordinates estimation of SLR stations, Bulletin of the Ukrainian Center of the Earth Orientation Parameters. No 2. pp 17-20. 2007.
- Bolotina O., Samoilenko A.N., Bolotin S.L. et al., Investigation of local ties of reference points of collocation station “Simeiz-Katzively”, Bulletin of the Ukrainian Center of the Earth Orientation Parameters. No 2. pp 21-25. 2007.
- Samoilenko O., Adamenko O., Bolotina O., Zayets V., Khoda O. The Results of the Third Geodetic Campaign at the Local Geodynamic Range MAO NAS of Ukraine, Kinematics and Physics of Celestial Bodies. Vol. 24, No 6. pp 452-462. 2008.
- Yatskiv Ya., Bolotina O., Veles O., Sergeeva T., MAO NASU in the structure of the international data base, Proceedings of IX International scientific conference “System analysis and Information techniques”, Kiev, Ukraine, 15-17 May, pp 25. 2007.

Contact

Dr. Olga Bolotina
Main Astronomical Observatory
of the NAS of Ukraine
Akademika Zabolotnoho Str., 27
Kiev, UKRAINE, 03680

Phone: +38 (044) 526-47-59
Fax: +38 (044) 526-21-47
E-mail: olga@mao.kiev.ua

Hitotsubashi University

Toshimichi Otsubo and Mihoko Kobayashi/ Hitotsubashi University (HIT-U)

Introduction

Hitotsubashi University became a new Associate Analysis Center of the ILRS in April 2007 when Toshimichi Otsubo moved from NICT. We hope to contribute to the ILRS over a long period of time.

Multi-Satellite Analysis Report

The daily quality check analysis was also moved from NICT to this university. The basic hardware/software component for this analysis remains almost the same; the main software engine is ‘concerto v4’ developed at NICT. We thank NICT for temporarily lending the computing facilities to us. Newly added satellites in the past two years are: GIOVE-A, -B, GLONASS-102, -109, -115, and Jason-2. In total, we analyze data from as many as 17 satellites daily although some satellites are occasionally dropped from the analysis report when the quality or quantity is not sufficient. We issue and upload a daily report (Figure 12-14) between 09:00-10:00 JST (00:00-01:00 UT). Upon a request from the ILRS Analysis Working Group, the station coordinates were switched from a modified ITRF2000 to the strict SLRF2005. Based upon some discussion within Task Force 1, we quickly issue e-mail alerts to the laser stations, as well as the Task Force, when we detect a series of obvious anomalous passes. More than 10 cases of such incidents occurred in 2008.

This quality control activity began in 1997. To commemorate our 10-year development and operation, we published a technical report in Journal of the Geodetic Society of Japan: T. Otsubo, M. Kobayashi, T. Gotoh and T. Kubo-oka: “Daily Quality Control System of Satellite Laser Ranging Data for the ILRS Network,” Journal of the Geodetic Society of Japan, Vol. 54, No. 2, 69-79, 2008 (in Japanese with English abstract) part of which was presented at the ILRS workshops in 2007 and 2008.

We would like to improve this reporting system based upon user input. We would appreciate any comments or requests on this work from the worldwide community of ILRS users.

Contact

Toshimichi Otsubo
Hitotsubashi University
East Bldg, 2-1 Naka, Kunitachi
Tokyo 186-8601
JAPAN

E-mail: t.otsubo@srv.cc.hit-u.ac.jp
Voice: 81-42-580-8939
Fax: 81-42-580-8939
Web: <http://geo.science.hit-u.ac.jp/>

Multi-Satellite Bias Analysis Report
for Worldwide Satellite Laser Ranging Stations

Geoscience Hitotsubashi

Latest Analysis Report: >> [from 12 May 2009 to 25 May 2009](#)

Stations with high productivity

	# pass/# NP	Site Name(ID)		# pass/# NP	Site Name(ID)
Lageos1	46/546	Yarragadee (7090)	Lageos2	34/483	Yarragadee (7090)
	40/555	Zimmerwald (7810)		27/404	Zimmerwald (7810)
	25/212	San Juan (7406)		22/171	San Juan (7406)
	25/202	Wetzell (8834)			
Etalon1	10/80	San Juan (7406)	Etalon2	11/110	Zimmerwald (7810)
	9/102	Yarragadee (7090)		7/52	Matera (7941)
	9/80	Zimmerwald (7810)		7/44	San Juan (7406)
Starlette	48/549	Yarragadee (7090)	Stella	29/254	Yarragadee (7090)
	38/218	Mt Stromlo (7825)		18/201	Washington (7105)
	36/373	Zimmerwald (7810)		17/186	Potsdam (7841)
		17/172		Zimmerwald (7810)	
				17/114	Wetzell (8834)
Ajisai	63/1168	Yarragadee (7090)		17/100	Mt Stromlo (7825)
	44/476	Mt Stromlo (7825)			
	35/452	Zimmerwald (7810)			
	35/412	San Juan (7406)			

more satellites (GNSS and LEO)
included in the daily reports!!

Archive: (each covers 14 days from the date) Year [2008](#) [2007](#) [2006](#) [2005](#)

[12 May 2009](#) [30 Apr 2009](#) [31 Mar 2009](#) [28 Feb 2009](#) [31 Jan 2009](#)
[11 May 2009](#) [29 Apr 2009](#) [30 Mar 2009](#) [27 Feb 2009](#) [30 Jan 2009](#)
[10 May 2009](#) [28 Apr 2009](#) [29 Mar 2009](#) [26 Feb 2009](#) [29 Jan 2009](#)
[09 May 2009](#) [27 Apr 2009](#) [28 Mar 2009](#) [25 Feb 2009](#) [28 Jan 2009](#)
[08 May 2009](#) [26 Apr 2009](#) [27 Mar 2009](#) [24 Feb 2009](#) [27 Jan 2009](#)
[07 May 2009](#) [25 Apr 2009](#) [26 Mar 2009](#) [23 Feb 2009](#) [26 Jan 2009](#)
[06 May 2009](#) [24 Apr 2009](#) [25 Mar 2009](#) [22 Feb 2009](#) [25 Jan 2009](#)

Figure 12-14. Multi-satellite bias analysis webpage at Hitotsubashi University (<http://www.science.hit-u.ac.jp/otsubo/slr/bias/>).

Institute of Applied Astronomy (IAA)

Iskander Gayazov, George Krasinsky, Eleonora Yagudina/IAA

Operational EOP Determinations

Daily operational processing of LAGEOS-1 and -2 observations is performed using GROSS software in support of the IAA EOP Service. Results are submitted to the OPA and NEOS combination centers.

Analysis of LLR Data (G. Krasinsky, E. Yagudina)

LLR data (1970–2008) have been processed to improve the lunar portion of the numerical luni-solar ephemeris of the program package ERA. The dynamical model of the lunar rotation takes into account the effects of elasticity of the lunar body and the tidal dissipation in the Moon. Values of 65 parameters have been estimated and fed back into the theory by iterations. Making use of the calculated partial derivatives, the LLR observations were also processed applying DE403, DE405 and DE421 theories. The pre-fit, post-fit residuals are presented in Table 12-4 (while calculating the pre-fit values for the DE theories, only corrections to the coordinates of the laser stations and the lunar reflectors, and the lunar Love numbers h_2 , l_2 might be implemented).

Table 12-4. WRMS errors for pre-fit and post –fit LLR residuals.

Ephemeris	Pre-fit RMS, cm	Post-fit RMS, cm	Number of LLR observations
DE403	23.66	5.24	16105
DE405	23.20	5.10	16102
DE421	22.06	5.06	16087
ERA	6.32	6.32	16115

Somewhat larger post-fit WRMS errors for the ERA theory have proven to be due to the simplified method of taking into account the dissipative effects in the lunar rotation. More correct modeling is required in order to integrate differential equations of lunar rotation with the retarded time-argument. At present, such work is in progress. Our analysis has demonstrated that while the orbital and rotational parts of the DE lunar ephemerides are of high internal accuracy, some of their parameters still need improvement.

Analysis of laser measurements of LAGEOS-1 and LAGEOS-2 (1988-2003) for estimating the dynamical Love number k_2^d , and secular and seasonal variations of the coefficients J_2 of geopotential (G. Krasinsky)

The measured laser distances to LAGEOS-1 and LAGEOS-2 (time interval 1988-2003, about 1.5 millions of measurements) have been processed using the program package ERA. Combining the observations of each year into one series, all weekly sub-series involved were processed simultaneously, determining for each week the elements of the satellites and other local parameters. For each year the estimates of the so-called dynamical Love number k_2^d were derived. (The dynamical Love number k_2^d is a scaling factor of the near-diurnal oscillations of the coefficients C_{21} , S_{21} caused by the differential rotation of the fluid core; in a commonly used equivalent approach, this effect is interpreted as a frequency dependence of the Love number k_2 in the near-diurnal frequency band). Yearly derived estimates of k_2^d (15 estimates for LAGEOS-1 and 9 estimates for LAGEOS-2) after averaging provide the value $k_2^d = 0.0613 \pm 0.0013$ in good accordance with the theoretical value $k_2^d = 0.063$. Simultaneously, weekly corrections to the adopted value of the coefficient J_2 of geopotential were also derived, considering these corrections be constant for each monthly interval. The set of these corrections was fitted by a model that includes a constant shift, linear secular trend and the sine- and cosine terms of the annual and semi-annual periods.

$$dJ_2 = A_0 + A_1 T + A_c \cos(\omega T) + A_s \sin(\omega T) + A_{2c} \cos(2\omega T) + A_{2s} \sin(2\omega T),$$

where T is the time elapsed from the epoch 2000.0 and ω is the annual frequency. For the amplitudes of the annual and semi-annual terms the following statistically significant estimates are derived:

$$\begin{aligned} A_s &= (-1.49 \pm 0.16) \times 10^{-10}, & A_{2s} &= (1.67 \pm 0.16) \times 10^{-10}, \\ A_c &= (-1.74 \pm 0.16) \times 10^{-10}, & A_{2c} &= (-0.66 \pm 0.16) \times 10^{-10}. \end{aligned}$$

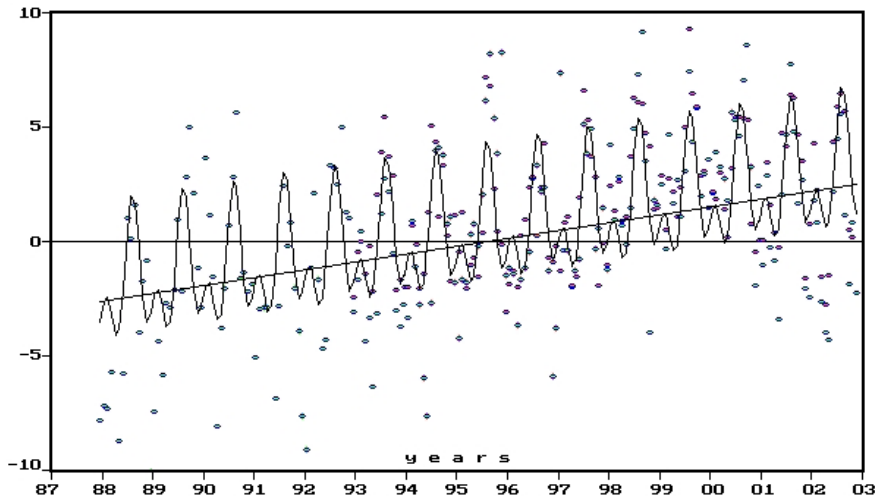

The amplitude and phase of the annual variations are consistent with the corresponding results of other studies, parameters of the semi-annual variations seem to be obtained for the first time. The observed corrections dJ_2 is presented in Figure 12-15, as well as the six-parametric model referenced above (the solid line). This more complete model demonstrates a spike in July-August and a practically constant value in other months. Note that Figure 12-15 presents not absolute variation of J_2 but the variation of J_2 calculated with the adopted negative trend recommended by IERS standards.

Figure 12-15. Observed and modeled variations of the corrections dJ_2

The evident positive trend in the corrections dJ_2 presented by the straight line means that the adopted negative trend $dJ_2/dt = -26 \times 10^{-10}/\text{cy}$ (and recommended by IERS standards [2]) should be significantly diminished and becomes negligible on the 3σ level:

$$dJ_2/dt = (9 \pm 3) \times 10^{-10}/\text{cy}.$$

This statement is true only for the considered time interval 1988-2003.

References

- Krasinsky, G. Estimating the dynamical Love number k_2^d from the analysis of the laser ranging data of LAGEOS- and LAGEOS-2. Transactions of IAA, 2009 (in press).
- Yagudina, E. Lunar numerical theory EPM2008 from analysis of LLR data. Proceedings of Journées 2008., Dresden, 22-24 September 2008 (in press).

Contacts

Iskander S. Gayazov
George A. Krasinsky
Eleonora I, Yagudina
Institute of Applied Astronomy
Kutuzov Quay 10
1191187 St Petersburg
RUSSIA

E-mail gayazov@pa.nw.ru
E-mail kra@ipa.nw.ru
E-mail eiya@ipa.nw.ru

Information-Analytical Center (IAC), formerly Mission Control Center (MCC)

Vladimir Glotov/Information-Analytical Center

Introduction

The Information-Analytical Center (IAC) of the Coordinate-Time and Navigation Service (previously known as the Mission Control Center/MCC) has been involved in SLR data analysis since 1990. The IAC has continued our activities in several areas: the determination of Earth Orientation Parameters (EOPs), SLR network quality control, studies in the use of SLR measurements of GLONASS satellites to check the quality of the available microwave-based orbital solutions, and support of the Russian SLR network and Russian SLR missions (Larets, BLITS, etc.).

For the convenience of the user community, we will continue to use the abbreviation MCC in the names of files and products and plan to transition to using the abbreviation IAC in the near future.

Facilities/Systems

The IAC SLR analysis group utilizes three of its own PC-oriented software packages in routine activities: STARK, POLAR, and STARK-AUTO&STARK-SYSTEM (SLR, GPS/GLONASS “phases” and code navigation data processing in the near-automatic regime).

Current Activities

Weekly EOP Estimation and SLR Network Quality Control

The IAC began routine determination of EOP in cooperation with the IERS in 1993. Based on SLR data from the LAGEOS-1 and -2 satellites, IAC (MCC) EOP estimations are sent to the Central and Rapid IERS Bureaus. Plots are available at <http://maia.usno.navy.mil/plots.html>.

In 1996, the IAC (MCC) began a regular service of assessing performance of the SLR stations. All LAGEOS-1 and -2 data are analyzed to obtain values of time and range biases and RMS. This routine service requires two levels of data filtering: automatically exclusion of outliers and problem sessions and running a manual check and correction of the results. Since 2008, we have sent these analysis reports daily for the SLReport publication.

The IAC SLR analysis group also provides the satellite prediction files in the Consolidated Prediction Format (CPF) for the Russian SLR missions (Larets and the planned BLITS).

GLONASS Orbit Determination and Verification

The IAC has made contributions to the International GNSS Service (IGS) by providing precise orbits based on SLR observations for those GLONASS satellites that are observed by the ILRS network. These independent orbits help to validate and evaluate precise orbits computed by analysis centers from the IGS tracking network observations. Since 1995, the IAC has supported orbit determination of GLONASS satellites based on SLR data. Orbits for GLONASS satellites (in SP3 format) are regularly sent to the IGS global data center at the CDDIS for the determination of the final orbits based mainly on the GLONASS “phase” data.

Future Plans

The IAC will continue its ILRS-related activities through the routine processing and analysis of SLR data.

Contact

Vladimir Glotov (coordinator)
Vladimir Mitrikas (main expert)
Sergey Revnivych (administrative support)
Information-Analytical Center (IAC)
of Coordinate-Time and Navigation Service
4 Pionerskaya Street
Korolyov, Moscow Region 141070
RUSSIA

Email: vladimir.glotov@mcc.rsa.ru
Email: vladimir.mitrikas@mcc.rsa.ru
Email: sergey.revnivych@mcc.rsa.ru

Japan Aerospace Exploration Agency (JAXA)

Takahiro Inoue, Shinichi Nakamura, Ryo Nakamura/Flight Dynamics Division, JAXA

Introduction

One of the tasks of the JAXA Associate Analysis Center is to provide the precise orbit determination for Ajisai, LAGEOS-1, and LAGEOS-2. In addition, JAXA has performed precise orbit determination experiments for the ALOS mission using onboard GPS receiver data and its accuracy evaluation using SLR data. JAXA has also performed the clock synchronization experiments using ETS-8, a geostationary satellite launched in December 2006. In 2009, SLR tracking of SOHLA-1 will be performed to evaluate the navigation accuracy, which comes from an onboard COTS GPS receiver.

Facilities/Systems

JAXA developed and completed a precise orbit determination system that uses both GPS and SLR data. In comparison with last year, we adopted some correction models, including a solar radiation pressure model. We also changed our observational model from the IERS 1996 standard to the IERS 2003 standard. The JAXA SLR station at Tanegashima was completed by the end of March 2004.

Current and Upcoming Activities

- Processing SLR tracking data of Ajisai, LAGEOS-1, and LAGEOS-2.
- Generating CPF predictions for the above satellites.
- Processing GPS satellite data (SLR normal point and RINEX) for precise orbit determination. Comparison of our orbit determination results with those of the IGS analysis center shows that our precise orbit determination system has almost equivalent performance as an IGS analysis center.
- Analyzing the data obtained from ETS-8. The analysis shows that the accuracy of orbit determination and time synchronization has achieved within about 20m (RMS) and 10 nsec.
- Confirming navigation accuracy of the GPSR instrument onboard SOHLA-1.

Current and Future Satellite Missions

ETS-8

ETS-8 is an advanced satellite developed primarily to establish and verify the world's largest-class geostationary satellite bus technology, which is necessary for space missions at the beginning of the 21st century. ETS-8 was launched in December 2006 and has been conducting orbital experiments on the Large-scale Deployable Reflector (for S-band), which is widely applicable to large-scale space structures, as well as the High-Power Transponder, and the On-Board Processor, which are all required to realize mobile satellite communications with hand-held terminals, similar to popular cellular phones. Moreover, the ETS-8 satellite carries the High Accuracy Clock (HAC) system and a Time Compare Equipment (TCE) system for the study of satellite positioning system. SLR data from ETS-8 is essential for these two experiments. Laser ranging can be performed to ETS-8 from the stations of WPLTN including the Tanegashima JAXA-station. JAXA carried out the link budget calculation in consideration of the station performance and verified the possibility of SLR tracking. Consequently, the ILRS stations Mt. Stromlo, Yarragadee, Koganei, Changchun, and Beijing became candidate tracking stations for ETS-8. JAXA has requested that these stations range to ETS-8 once every two weeks [1].

SOHLA-1

SOHLA-1 is a 50kg-class spin stabilized satellite, which was manufactured by universities and middle and small-sized enterprises joining in an organization called SOHLA (Space Oriented Higashiosaka Leading Association) established to embark on space business. The mission of SOHLA-1 is the engineering demonstration by a 50kg-class micro satellite for validation of techniques to identify a location of lightning discharge on the Earth. Other goals of the mission include a short period of development time and a low cost. SOHLA-1 carries a newly developed miniature GPS receiver and a Laser Reflector Array (LRA). Since one of the goals of SOHLA-1 is to evaluate the GPS receiver's performance, SLR data are needed in order to calibrate the receiver's data. In March 2009, JAXA requested all ILRS stations range SOHLA-1, and will request another campaign around the end of 2009 [2].

QZS

The QZSS (Quasi-Zenith Satellites System) is a constellation of several identical satellites (Figure 12-16), with at least one satellite positioned near zenith over Japan at all times; the first satellite will be launched in 2010. Users can receive the communication and positioning signals from one of QZSS near zenith direction without obstruction in urban and mountainous areas. Due to this advantage, people in moving vehicles and using mobile phones can speak and send/receive high quality content without interference. In addition, the system, used together with a GPS, will provide much more accurate positioning information than with GPS alone. The system is aimed at improving availability of GPS signals for relevant users through QZSS, which is equipped with instruments capable of generating and transmitting signals compatible with modernized GPS signals. SLR ranging data from QZS are essential for these missions in order to transmit precise orbit ephemeris through a navigation message similar to GPS.

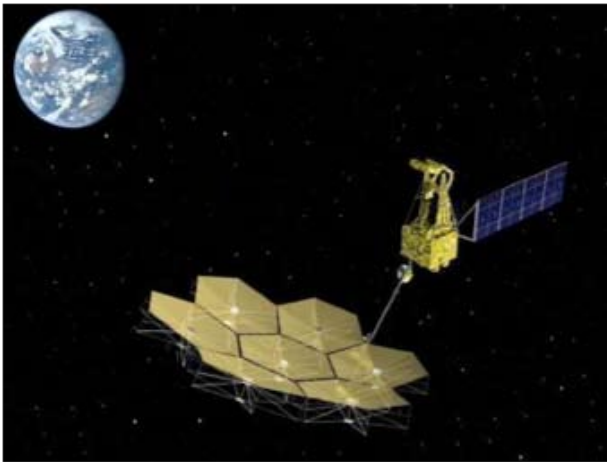

Figure 12-16. QZSS constellation of QZSS



Figure 12-17. ASTRO-G satellite

ASTRO-G

ASTRO-G (Figure 12-17) is a next-generation space radio telescope designed to reveal phenomena such as the relativistic phenomena in the space around super-massive black holes at the centers of galaxies. ASTRO-G will be launched in 2012 and injected into an elliptical orbit with an apogee height of 25,000 km and a perigee height of 1000 km. The project features direct imaging observation of astronomical phenomena with a level of high-spatial resolution (40 micro arc sec. at its best) never achieved before. In order to successfully conduct a phase referencing observation, one of the observation modes in which the antenna points to a target radio source and a calibration source in a switching manner, requires precise orbit determination (POD). The accuracy requirement is at least 10 cm. In order to achieve the orbit determination accuracy, the satellite will carry a GPS receiver and a laser retro-reflector array (LRA) for SLR [3].

References

- [1] ETS-8 Tracking Standard, <http://god.tksc.jaxa.jp/>
- [2] T. Inoue et al, "SLR Return Analysis for SOHLA-1", http://ilrs.gsfc.nasa.gov/docs/ILRS_Sohla_lw16.pdf
- [3] R. Nakamura et al, "SLR Return Analysis for ASTRO-G",
http://cdis.gsfc.nasa.gov/lw16/docs/presentations/ops_11_Inoue.pdf

Contacts

Shinichi Nakamura	Phone: +81-29-868-2624
Ryo Nakamura	Phone: +81-29-868-2616
Takahiro Inoue	Phone: +81-29-868-2627
JAXA	Fax: +81-29-868-2990
Flight Dynamics Division	
Consolidated Space Tracking and Data Acquisition Department	
Office of Space Flight and Operations	
JAPAN	

Newcastle University

Philip Moore, Peter J. Clarke/Newcastle University.

The School of Engineering and Geosciences (CEG) at Newcastle University has continued its activity in space geodesy involving SLR, DORIS, VLBI, GNSS and altimetry. SLR activities utilize our in-house software FAUST. Our ILRS Associate Analysis center activities over the past two years have involved precise orbit determination of geodetic satellites with application to geocenter motion, temporal variation in Earth's gravity field and synergy of tracking techniques.

SLR analyses within precise orbit determination of LAGEOS-1 and LAGEOS-2 in particular have been used to infer temporal variability for the lower order and degree gravitational harmonics along with station coordinates, etc. directly from the tracking data. The station coordinates are subsequently used along with the gravitational results to infer degree one harmonics associated with geocenter motion.

Inversion of geodetic site displacement data to infer surface mass loads normally uses a spherical harmonic representation of the load. This method suffers from the continent-rich, ocean-poor distribution of the geodetic data. Fine-scale inversion rapidly becomes unstable due to the rapidly increasing number of parameters, which are poorly constrained by the data geometry. Several approaches have previously been tried to mitigate this, including the adoption of constraints over the oceanic domain derived from ocean circulation models, the use of smoothness constraints for the oceanic load, and the incorporation of GRACE gravity field data. However, these methods do not provide appropriate treatment of mass conservation and of the ocean's equilibrium-tide response to the total gravitational field. We have proposed a modified set of basis functions as an alternative to standard spherical harmonics that allow variability of the load over continental regions, but impose global mass conservation and equilibrium tidal behavior of the oceans. Tests of the basis functions for efficiency of fitting to realistic modeled surface loads, and for accuracy of the fit of the inferred load using synthetic geodetic displacements to the known model load have shown a better fit to the model loads and provide a more accurate and stable fit using the synthetic geodetic displacements than conventional spherical harmonics. The modified basis functions have been employed within comparisons of SLR and GNSS signatures against those from the GRACE mission. Results to date have revealed that degree 2 and 3 harmonics from SLR complement the higher degree variability obtainable from GNSS and GRACE.

Additional SLR studies with LAGEOS, Starlette, and Stella have been used for teaching purposes and for final year undergraduate projects.

Contact

Philip Moore
Department of Geomatics, Newcastle University
Newcastle, NE43 7RU
UNITED KINGDOM

Voice: + 44 (0)191 222 5040
E-mail: Philip.Moore@ncl.ac.uk

National Institute of Information and Communications Technology (NICT)

Tadahiro Gotoh/NICT

Introduction

NICT has developed precise orbit determination software, ‘concerto v4’ and utilizes this software to study the improvement of the force models acting on satellites. During the 2007-2008 timeframe, we have mainly studied the non-gravitational perturbation model.

Ajisai Orbit Determination using Anisotropic Radiation Pressure (Sengoku) Model

The Ajisai satellite strongly suffers from a non-gravitational perturbation force because of its large diameter and light mass. The Japan Coast Guard has developed a precise anisotropic radiation pressure model for Ajisai. We implemented this force model into the concerto v4 software, and evaluated the orbit determination accuracy when compared to a simple “cannonball model”. The orbit determination accuracy improved by a factor of 1.3 compared to the cannonball model.

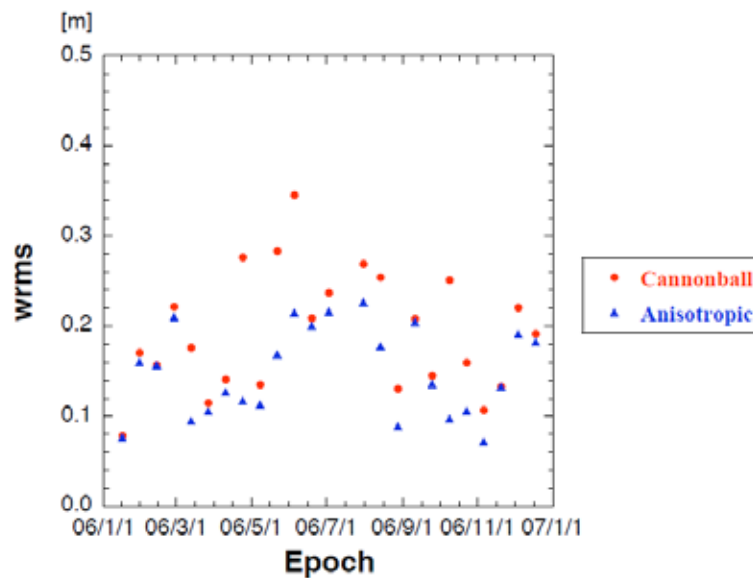

Figure 12-18. Post-fit residual wrms after least square adjustment.

Study of Non-gravitational Perturbation Model for ASTRO-G Satellite

ASTRO-G is the radio astronomy satellite for the next space VLBI observation program. The mission requires accurate orbit determination to a few centimeters despite the fact that its orbit is highly elliptic. Since the GPS satellites tracked in the vicinity of apogee by the onboard receiver are fairly old (decaying), a precise force model is necessary to maintain orbit quality over that region of the trajectory. Development of a non-gravitational perturbation model is ongoing at NICT, in collaboration with JAXA. We have computed the dense radiation forces acting on the entire satellite by applying a ray-tracing method of computer graphics, and developed the macro model based on those forces.

Contacts

Tadahiro Gotoh
NICT
4-2-1 Nukui-Kita
Koganei, Tokyo, 184-8795
Japan

Phone: 81 42 327 6850
Fax: 81 42 327 6664
E-Mail: tara@nict.go.jp

Toshihiro Kubo'oka
NICT
893-1 Hirai
Kashima, Ibaraki 324-8501
Japan

Phone: 81 299 84 7181
Fax: 81 299 84 7160
E-Mail: tkubooka@nict.go.jp

Shanghai Astronomical Observatory (SHAO)

Xiaoya Wang, Xiaogong Hu, Yuanlan Zhu, Weijing Qu, Bin Wu/SAO

Introduction

The main tasks of the Shanghai Astronomical Observatory (SHAO) Associate Analysis Center are to perform SLR data quick-look processing for LAGEOS and provide weekly range and time bias analysis reports to the ILRS. In addition, SHAO has performed some precise orbit determination for Compass/Beidou using SLR data and microwave signals and evaluated their orbit accuracy. SHAO has also been preparing for automated SLR data processing including specifying a satellite (any satellite with SLR data is allowed), downloading data, preparing files, executing software, and outputting results. We have also been preparing for weekly SLR SINEX solutions using our multi-satellite SLR data processing software.

Facilities/Systems

SHAO developed and completed two precise orbit determination systems (SHODE I and COMPASS) for SLR. SHODE I is single satellite processing software and can only process one satellite at a time; COMPASS, however, can process multi-satellite data. We have also developed another software system (SHODE II) that incorporates both GPS data and SLR data. We plan to compare results and investigate new models, which will allow us to modify our software to provide ILRS products.

LAGEOS Quick-Look Processing Analysis

SHAO has been operating our weekly quick-look data analysis since 1999. The main objectives of this activity are a semi real-time quality control (QC) of the global SLR observations on LAGEOS-1 and LAGEOS-2 and on their orbits. Those orbits can be used in the calibration of some radar satellites. The weekly analysis report is provided to the ILRS. Prior to 2008, our colleagues Yuanlan Zhu and Cheng Huang performed this work; after 2008 Dr. Wang and Dr. Hu assumed responsibility for this activity at the SHAO AAC. Since 2008, a PhD student (Weijing Qu) produces these weekly analysis reports; we plan to fully automate our data processing in the near future.

SHAO reviewed the related models and constants used in our processing during 2007 and 2008 (see our AAC description at http://ilrs.gsfc.nasa.gov/reports/analysis_reports/SHAO-QC.dsc.txt). We continue to use the ITRF2000 reference frame because the residual rms becomes too large when using ITRF2005. We will continue to study possible changes to our software to include the new IERS convention models and reference frame. Typical rms-of-fit values are in the range of 10 to 20 mm. We also hope to induce the corrections for atmospheric pressure loading and the estimation of the geocenter after our auto-processing is completed. Based on initial tests, we hope to generate analysis reports including Etalon and perhaps additional satellites. We continue to compare the range and time biases of individual LAGEOS-1 and -2 passes with the estimates obtained by other analysis centers (DGFI and Hitotsubashi University), and strive to give the stations a realistic feedback on the performance on their equipment. This work continues in test phase at this time.

Our most important action item is the reactivation of our analysis procedures. SHAO intends to introduce several new elements in the operational analysis: (1) the dissemination analysis results through the network, (2) the addition of other satellites, probably Etalon-1 and -2, (3) the implementation of new models to handle the refraction effects.

Compass Precise Orbit Determination

Compass, the Chinese satellite navigation system, launched the test satellite Compass-M1 on April 13, 2007. A laser reflector array was installed on Compass-M1. The satellite has microwave tracking data but unfortunately no SLR data were available until December 2008. We analyzed some microwave tracking data based on a regional

network and validated the orbit accuracy with SLR data during 2007. The accuracy is in the order of a meter. The orbit determination based only on SLR tracking data began in December 2008 and is calculated once every three days. We succeeded in determining SLR-only orbits of Compass covering data arcs of seven days with a three-day overlap both at the beginning and at the end of the arc. The residual rms is typically better than 5 cm with values better than 1 cm in the best situations. Additional details will be presented at the ILRS Technical Workshop on SLR Tracking of GNSS Constellations to be held in Greece in September 2009. All SLR related results will be available on the SHAO web site currently under development.

Recent Activities

Recently, we completed our auto-processing system that includes weekly quick-look processing analysis, post-processing that provides weekly loose SINEX solutions, and long time series analysis based on SINEX solutions. In addition, SHAO has performed precise orbit determination for Compass. In the very near future we will start the pre-processing and analysis of LAGEOS-1 and -2 data and provide SINEX-formatted solutions for site coordinates, EOP, and geocenter time series.

Future Plans

Most current activities will continue, with particular attention to the ILRS and IERS oriented products. During automatic processing, a number of quality checks are performed and the weekly results of the bias analysis will be sorted by satellite and year and be available from the SHAO web server. We will continue to explore the application of multi-satellite analysis to the long time series of EOP, station coordinates and velocities, and the position variation of Earth's mass center. We will also do some comparisons based on our different software. In addition, we will test our combined analysis of microwave data and SLR data based on SHODE II and demonstrate the possible improvement in the orbit accuracy.

Contact

Dr. Xiaoya Wang

E-mail: wxy@shao.ac.cn

Phone: 86-21-64386191-296

Dr. Xiaogong Hu

E-mail: hxg@shao.ac.cn

Phone: 86-21-64386191-216

Dr. Xiaogong Hu

Shanghai Astronomical Observatory

Chinese Academy of Sciences

80 Nandan Road

Shanghai 200030

CHINA

ILRS LUNAR ASSOCIATE ANALYSIS CENTER REPORTS

Lunar Associate Analysis Centers process normal point data from the Lunar Laser Ranging (LLR) stations and generate a variety of scientific products including precise lunar ephemerides, librations, and orientation parameters which provide insights into the composition and internal makeup of the Moon, its interaction with the Earth, tests of General Relativity, and Solar System ties to the International Celestial Reference Frame.

Institut fuer Erdmessung/Forschungseinrichtung Satellitengeodaesie (IFE/FESG)

Jürgen Müller, Liliane Biskupek, Franz Hofmann/IfE, Ulrich Schreiber/FESG

Recent Activities

The transformation between the celestial and terrestrial systems was updated according to the IERS Conventions 2003. The transformation, however, is still implemented following the equinox-based representation using the IAU 2000A precession-nutation model, not the CIO-based version. Further model changes covered the gravity field of Earth and the loading effects of the atmosphere and the ocean. Also new initial values for our own ephemerides computation, based on JPL ephemeris DE405, have been introduced.

The IAU 2000 nutation model is described in the IERS Conventions 2003 as a series for nutation in longitude $\Delta\psi$ and obliquity $\Delta\epsilon$, referred to the mean ecliptic of date:

$$\Delta\psi = \sum_{i=1}^N (A_i + A_i' t) \sin(ARG) + (A_i'' + A_i''' t) \cos(ARG)$$

$$\Delta\epsilon = \sum_{i=1}^N (B_i + B_i' t) \cos(ARG) + (B_i'' + B_i''' t) \sin(ARG)$$

with t in Julian centuries from epoch J2000 and $ARG = \sum_j^5 N_j F_j$, N_j : multipliers, F_j : Delaunay parameters. With

the updated analysis software, the nutation coefficients A_i, A_i'', B_i and B_i'' of different periods (18.6 and 9.3 years, 1 year, 182.6 and 13.6 days) were determined and compared to the values of the MHB2000 model of Mathews et al. (2002). Table 5 gives our preliminary results. The post-fit residuals of the standard solution were processed to determine corrections for Earth rotation ΔUT_0 and variation of latitude $\Delta\psi$ with the daily decomposition method.

Another study covered data from the new observatory APOLLO (Apache Point Observatory Lunar Laser-ranging Operation in New Mexico, USA). The APOLLO data set was analyzed for outliers and possible biases. For the overall weighting, which is based on the accuracy estimates of the observatory, the accuracy of the observed Earth-Moon distances was reduced by 0.1 ns to make the new data consistent with our LLR system. The APOLLO data improve the overall quality of our LLR solution. Furthermore, the data set of all observatories was analyzed for biases, affecting the normal points over short periods. But no new significant biases were found besides the known ones.

In the area of relativity, a study related to the parameterization of gravito-magnetic effects by means of LLR was carried out. The corresponding terms in the equation of motion were parameterized introducing a new quantity ηG . Furthermore, the preferred-frame parameter α_1 was introduced in the equations of motion given in the extended PPN framework (Will, 1993) and was analyzed in our global adjustment. Frame-dependent effects due to the gravito-magnetic effect as predicted by Einstein's theory could be verified at the 10^{-3} level. For more details see Soffel et al. (2008).

Table 12-5. Nutation coefficients from IfE LLR computation

Period	A_j [mas]	B_j [mas]	A_j'' [mas]	B_j'' [mas]
18.6 years	-17201.93	9203.41	3.84	3.88
182.6 days	-1316.88	572.98	-3.25	-0.98
13.6 days	-230.54	99.26	0.16	0.31
9.3 years	207.13	-90.75	1.63	-0.21
1 year	146.83	7.86	0.27	-0.58

Ongoing Activities and Future Plans

In February 2009, a new co-worker, Franz Hofmann, started in the cluster of excellence QUEST (Centre for Quantum Engineering and Space-Time Research). One task group of this cluster focuses on possible modifications of Einstein's theory. Here, IfE will support this work by improved modeling and analysis of LLR data and investigation of relativistic parameters.

The LLR model has been improved, by updating the model of the lunar interior with support from Jim Williams (JPL). A next step will be to update the modeling of the effect from the asteroids. The determined nutation coefficients will be compared with VLBI results in the future. Also comparisons on the level of normal equations are planned.

Publications

- Biskupek, L., Müller, J.: Lunar Laser Ranging and Earth Orientation; in: *Astrometry, Geodynamics and Astronomical Reference Systems*, Proceedings of Journées "Syst mes de référence spatio-temporels" and X. Lohrmann-Kolloquium, Dresden, Germany, 22.-24.09.2008, submitted 2009.
- Biskupek, L., Müller, J.: Relativity and Earth Orientation Parameters from Lunar Laser Ranging, in: *Electronic Proceedings of the 16th International Workshop on Laser Ranging*, Poznan, Poland, 12.-17.10.2008, submitted 2009.
- Kopeikin, S. M., Pavlis, E., Pavlis, D., Brumberg, V. A., Escapa, A., Getino, J., Gusev, A., Mueller, J., Ni, W. -T., Petrova, N.: Prospects in the orbital and rotational dynamics of the Moon with the advent of sub-centimeter lunar laser ranging, *Advances in Space Research*, 42, 1378-1390, 2008.
- Müller, J.: Lunar Laser Ranging: A Space Geodetic Technique to Test Relativity, in: *Proceedings of the 11th Marcel Grossmann Meeting*, Berlin, 23.-29.07.2006, Kleinert, H.; Jantzen, R.T. & Ruffini, R. (eds.), World Scientific, Part C, 2576-2578, 2008.
- Müller, J., Biskupek, L.: Variations of the gravitational constant from lunar laser ranging data, *Classical and Quantum Gravity*, 24, 4533-4538, 2007.
- Müller, J., Soffel, M., Klioner, S. A.: Geodesy and relativity, *Journal of Geodesy*, 82, 133-145, 2008.
- Müller, J., Williams, J.G., Turyshev, S.G.: Lunar Laser Ranging Contributions to Relativity and Geodesy, in: *Lasers, Clocks and Drag-Free Control: Exploration of Relativistic Gravity in Space*, Dittus, H., Lämmerzahl, C. & Turyshev, S.G. (eds.), Springer, 349, 457-472, 2008.
- Soffel, M., Klioner, S., Müller, J., Biskupek, L.: Gravitomagnetism and lunar laser ranging, *Physical Review D*, 78, 024033, 2008.

Acknowledgment

We like to thank Jim Williams (JPL) for support and discussion in the field of lunar core and mantle modeling. We would also like to thank the DFG, the German Research Foundation, which funded this study within the research unit FOR584 “Earth rotation and global dynamic processes”.

References

Mathews, P.M., Herring, T.A., Buffett, B.A.: Modeling of nutation and precession: New nutation series for nonrigid Earth and insights into the Earth’s interior, *J. Geophys. Res. (B4)*, 107, 10.1029/2001JB000390, 2002.
Will, C. M.: *Theory and Experiment in Gravitational Physics*, Cambridge University Press, England, 1993.

Contact

Prof. Dr.-Ing. Jürgen Müller

Voice: ++49 (0) 511-762 3362

Email: mueller@ife.uni-hannover.de

Dipl.-Ing. Liliane Biskupek

Voice: ++49 (0) 511-762 5784

Email: biskupek@ife.uni-hannover.de

Dipl.-Ing. Franz Hofmann

Voice: ++49 (0) 511-762 5783

Email: hofmann@ife.uni-hannover.de

Leibniz Universität Hannover
Institut für Erdmessung
Schneiderberg 50
30167 Hannover
GERMANY

Jet Propulsion Laboratory (JPL)

James G. Williams, Dale H. Boggs, Slava G. Turyshev, Jean O. Dickey, J. Todd Ratcliff/JPL

Analysis and Science Activities 2007-2008

Lunar Laser Ranging (LLR) data analysis at JPL has fit the operational data sets from the McDonald, Observatoire de la Côte d'Azur (Grasse) and Apache Point Observatory sites plus historical data from Haleakala. A total of 16,960 normal points have been processed from 1970 through the end of 2008. Retroreflector arrays include Apollo 11, 14, and 15 missions and Lunokhod 2.

The computer code for lunar laser ranging data analysis continues to be reviewed and upgraded. Solutions now detect the lunar fluid core moment of inertia. Daily UT0 and variation of latitude solutions have been made for a 38 yr LLR data span.

Standard solution parameters now include ranging station coordinates and motions, Earth orientation, lunar orbit, tidal acceleration, GM of Earth+Moon, lunar orientation, Love numbers, tidal Qs, dissipation at and oblateness of the lunar fluid-core/solid-mantle boundary (CMB), moment of inertia of fluid core, mantle moment differences, gravity coefficients and retroreflector array positions. In addition, solutions were made for any equivalence principle violation (related to PPN beta and gamma), dG/dt, geodetic precession and scale change. Gravitational physics results are in agreement with general relativity.

With Nicolas Rambaux, we studied lunar free librations. The 2.9 yr longitude and 74.6 yr wobble modes are strongly detected, but the 81 yr precession in space is much weaker. The free core nutation was not detected. There must be a source of stimulation for the two large modes.

DE418 and DE421 orbital ephemerides of the Moon and planets plus physical librations were generated and made publicly available. DE421 is available in two formats via ftp: <ftp://ssd.jpl.nasa.gov/pub/eph/planets/ascii/de421> and <ftp://ssd.jpl.nasa.gov/pub/eph/planets/bsp>.

Looking to future laser ranging activities, we investigate a corner cube design for future lunar landers. We also investigate transponders for future laser ranging to the Moon, Mars and Phobos.

Papers

- Müller, J., J.G. Williams, S.G. Turyshev, Lunar Laser Ranging Contributions to Relativity and Geodesy, in proceedings of 359th WE-Heraeus Seminar on "Lasers, Clocks, and Drag-Free: Technologies for Future Space Exploration in Space and Tests of Gravity," eds. H. Dittus, C. Lämmerzahl, S. Turyshev, 457-472, Springer, 2007. <http://arxiv.org/abs/gr-qc/0509114>
- Murphy, T.W., K. Nordtvedt, S.G. Turyshev, Gravitomagnetic Influence on Gyroscopes and on the Lunar Orbit, *Phys. Rev. Lett.*, 98, 071102, 2007. arXiv: gr-qc/0702028
- Murphy, T.W., W. Farr, W. Folkner, A. Girerd, H. Hemmati, S. Turyshev, J.G. Williams, J.J. Degnan, Testing Fundamental Gravity via Laser Ranging to Phobos, in proceedings of 16th Int. Workshop on Laser Ranging, in press, 2009.
- Turyshev S., J.G. Williams, Space-Based Tests of Gravity with Laser Ranging, *International Journal of Modern Physics D* 16 (12a), 2165-2179, doi:10.1142/S0218271807011838, (Dec) 2007. arXiv:gr-qc/0611095v1
- Williams, J.G., S.G. Turyshev, D.H. Boggs, "Williams, Turyshev, and Boggs Reply", *Phys. Rev. Lett.*, 98, (#5) doi: 10.1103/PhysRevLett.98.059002, (Feb 2) 2007.
- Williams, J.G., A Scheme for Lunar Inner Core Detection, *Geophysical Research Letters*, 34, L03202, doi:10.1029/2006GL028185, (Feb 9) 2007.
- Williams, J.G., D.H. Boggs and W.M. Folkner, DE421 Lunar Orbit, Physical Librations, and Surface Coordinates, JPL IOM 335-JW,DB,WF-20080314-001, March 14, 2008.

- Williams, J.G., S. Turyshev, D.H. Boggs, Lunar Laser Ranging Tests of the Equivalence Principle with the Earth and Moon, *Int. J. of Modern Physics D*, in press, 2009.
- Williams J.G., D.H. Boggs, Lunar Core and Mantle. What Does LLR See?, in proceedings of 16th International Workshop on Laser Ranging, in press, 2009.

Abstracts

- J. G. Williams, D. H. Boggs, and J. T. Ratcliff, Lunar Mantle and Fluid Core Results and Inner Core Possibilities, abs. #2004, *Lunar and Planetary Science Conf. XXXVIII*, March 12-16, 2007.
- S. G. Turyshev, J. G. Williams, and D. H. Boggs, Lunar laser ranging research: recent progress and future plans, American Geophysical Union meeting, San Francisco, CA, Dec. 10-14, 2007.
- J. G. Williams, D. H. Boggs, and J. T. Ratcliff, Lunar Tides, Fluid Core and Core/Mantle Boundary, abs. #1484 of *Lunar and Planetary Science Conference XXXIX*, March 10-14, 2008.
- N. Rambaux, J. G. Williams, and D. H. Boggs, A Dynamically Active Moon – Lunar Free Librations and Excitation Mechanisms, abstract #1769 of *Lunar and Planetary Science Conference XXXIX*, March 10-14, 2008.
- J. T. Ratcliff, J. G. Williams, and S. G. Turyshev, Lunar Science from Laser Ranging – Present and Future, abs. #1849 of *Lunar and Planetary Science Conference XXXIX*, March 10-14, 2008.
- S. G. Turyshev, J. G. Williams, H. Hemmati, and W. M. Folkner, New Laser-Ranging Instruments for Science Investigations on, of, and from the Moon, abstract #2134, NLSI Lunar Science Conference, Ames Research Center, July 20-23, 2008.
- B. Archinal, C. Acton, B. Bussey, B. Campbell, G. Chin, A. Colaprete, A. Cook, D. Despan, R. French, L. Gaddis, R. Kirk, W. Mendell, F. Lemoine, M. Nall, J. Oberst, J. Plescia, M. Robinson, D. Smith, K. Snook, T. Sweetser, R. Vondrak, M. Wargo, and J. Williams, Lunar Science Support by the NASA LPRP Lunar Geodesy & Cartography Working Group: Recommendations for Lunar Cartographic Standards, NLSI Lunar Sci. Conf., Ames Res. Center, July 20-23, 2008.
- J. G. Williams, Lunar Core and Mantle. What Does LLR See?, 16th Int. Workshop on Laser Ranging, Poznan, Poland, 2008. cdsis.gsfc.nasa.gov/lw16/docs/presentations/sci_1_Williams.pdf

Contacts

James G. Williams	E-mail: James.G.Williams@jpl.nasa.gov Phone: (818) 354-6466
Dale H. Boggs	E-mail: Dale.H.Boggs@jpl.nasa.gov Phone: (818) 354-1630
Slava G. Turyshev	E-mail: Slava.G.Turyshev@jpl.nasa.gov Phone: (818) 393-2600
Jean O. Dickey	E-mail: Jean.O.Dickey@jpl.nasa.gov Phone: (818) 354-3235
J. Todd Ratcliff	E-mail: James.T.Ratcliff@jpl.nasa.gov Phone: (818) 354-0204
Jet Propulsion Laboratory Mail Stop 238-600 4800 Oak Grove Drive Pasadena, CA 91109-8099 USA	Fax: (818) 393-4965

Paris Observatory Lunar Analysis Center (POLAC)

Sébastien Bouquillon, Jean Chapront, Gérard Francou /Observatoire de Paris

The lunar analysis center POLAC works in cooperation with the laser ranging team of the Observatoire de la Côte d'Azur (GRGS ILRS Analysis Center) and with the two IERS centers based at the Observatoire de Paris (EOP and ICRS centers). During these last two years, our activities have been reduced because of the retirement of Jean Chapront and the temporary break in the observations of Grasse (OCA). We have revisited the entire set of LLR observations made since 1969. This inventory has been performed with our existing archives completed with those given by Grasse and by James Williams. We have compared them to the observations already available at the data centers of ILRS. Some of these data, which were obviously wrong or redundant, have been corrected or excluded. Thus, more than 18,000 LLR normal points have been gathered with the same format over the time interval 1969-2008 divided into several units according to the sites and the periods of observations (Figure 12-19 and Table 12-6): McDonald 1969-2008, Grasse 1984-2005, Haleakala 1987-1990 and Apache Point 2006-2008.

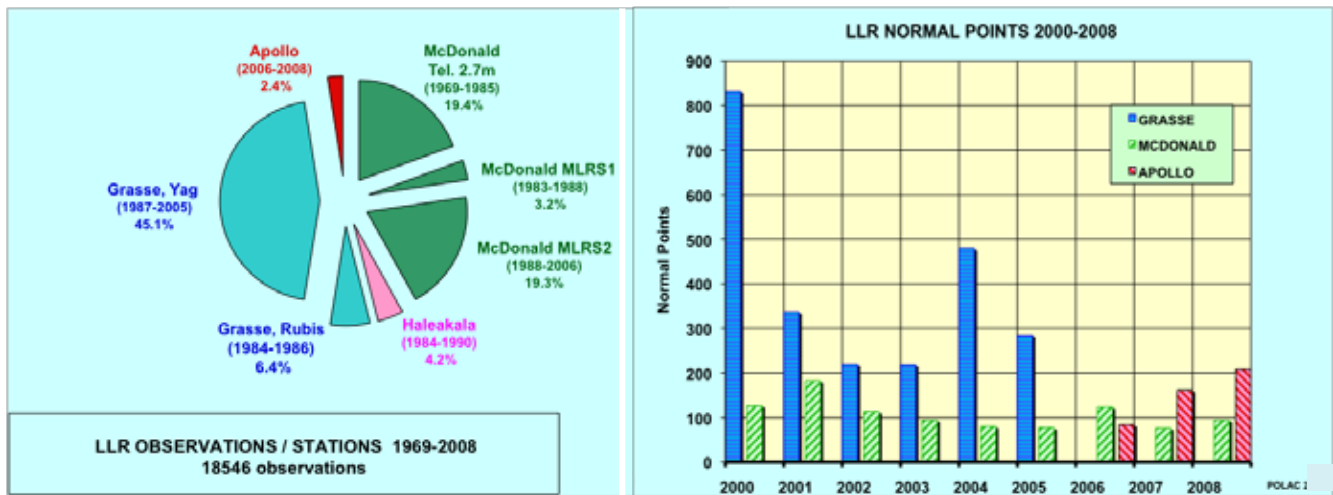

Figure 12-19a and -b. LLR data archive statistics

References

- Manche H., J. Laskar, A. Fienga, N. Capitaine, S. Bouquillon, G. Francou, M. Gastineau, 2008, "The geodesic precession in the INPOP ephemerides", Journées.2008 - Systèmes de référence spatio-temporels, Dresden, Germany, M. Soffel, N. Capitaine (eds.).
- Manche H., Bouquillon S., Fienga A., Laskar J., Francou G., Gastineau M., 2007, "Towards INPOP07, ajustements to LLR data", Journées 2007 - Systèmes de références spatio-temporels, Paris, France, N. Capitaine et al. (eds).
- Zerhouni W., N. Capitaine, G. Francou, 2008, "What could bring LLR observations in determining the position of the celestial pole", Journées 2008 - Systèmes de référence spatio-temporels, Dresden, Germany, M. Soffel, N. Capitaine (eds.).
- Zerhouni W., Capitaine N., Francou G., 2008, "The determination of the corrections to the IAU 2000A-2006 X,Y coordinates using LLR observations", Société astronomique de France.
- Zerhouni W., Capitaine N., Francou G., 2007, "The use of LLR observations (1969-2006) for the determination of the celestial coordinates of the pole", Journées 2007 - Systèmes de références spatio-temporels, Paris, France, N. Capitaine et al. (eds).

Table 12-6. Available LLR Normal Points

Stations and Instruments	Periods of the Observations	rms of the Post-Fit Residuals
McDonald Tel 2.7m	1969-1976	45.4 cm
McDonald Tel 2.7m	1976-1980	24.4 cm
McDonald Tel 2.7m	1980-1986	23.0 cm
McDonald MLRS1	1983-1988	29.3 cm
McDonald MLRS2	1988-1991	5.6 cm
McDonald MLRS2	1991-1995	3.9 cm
McDonald MLRS2	1995-2001	3.5 cm
McDonald MLRS2	2001-2008	8.0 cm
Haleakala	1984-1990	7.0 cm
Grasse Rubis	1984-1987	16.3 cm
Grasse Yag	1987-1991	5.5 cm
Grasse Yag	1991-1995	4.0 cm
Grasse Yag	1995-2002	3.2 cm
Grasse Yag	2002-2005	4.5 cm
APOLLO	2006-2008	4.1 cm

Contact

POLAC
 Observatoire de Paris (SYRTE)
 61 avenue de l'observatoire
 75014 Paris
 FRANCE

E-mail : polac.contact@obspm.fr

SECTION 13
ILRS STATION REPORTS



FRASER PANGLOSS



SECTION 13

ILRS STATION REPORTS

Arequipa, Peru

Raul Yanyachi/Universidad Nacional de San Agustin, David Carter/NASA GSFC

TLRS-3 System (Arequipa, Peru)



Figure 13-1. TLRS-3 in Arequipa Peru.



Figure 13-2. TLRS-3 station crewmembers, David Carter, Claudia Carabajal, Dennis McCollums, and UNSA customs personnel.

The TLRS-3 NASA station, located in Arequipa, Peru, officially reopened on February 12, 2007 in a formal rededication ceremony, with the presence of local dignitaries and the U.S. ambassador. Dennis McCollums from HTSI arrived in January 2007 to perform repairs and upgrades, while in February 2007 David Carter and Philip Liebrecht from NASA, Julie Horvath from HTSI, and Mike Pearlman from the ILRS, arrived at the station for the reopening ceremony.

During the 2007 and 2008 period, the TLRS-3 system underwent several upgrades and repairs, while steadily tracking satellites. The system was upgraded with a new chiller, a smart UPS, and a calibrated MET3 package. In April 2007, Jim Long and Troy Carpenter, from HTSI, arrived to perform a total station site survey for the TLRS-3 SLR system, the GPS receiver, and the DORIS antenna.

In January 2008, lightning struck near the SLR station and damaged the station power lines. Eventually, many of the station's systems, including the PC controller, the CAMAC, and the time code generator, began experiencing problems. After several months the problem was solved by performing maintenance on the main transformer, the power panel, and system ground. The power cables were uncovered, replaced and inserted into a new protective tube. The time code generator was also replaced.

At the end of 2007 and early 2008, the crew identified a small telescope mount vibration in elevation due to tachometer problems. This problem became significantly worse by the end of September 2008, and SLR tracking was severely affected and was restricted to only daytime hours.

In March 2008, the SLR station manager, Dr. Raul Yanyachi, traveled to the Goddard Space Flight Center in Greenbelt, Maryland to participate in training at the HTSI facilities on all aspects of the SLR systems, including SLR operations, and SLR system and subsystem repair.

On September 11, 2008, the new U.S. ambassador in Peru, Mr. Michael McKinley, visited the station accompanied with three functionaries of the embassy Paul Degler (Cultural Affairs Officer), Dionadrea Shorts (Embassy Functionary), Miguel Yepez (Embassy Economic Specialist); and Dr. Valdemar Medina the Vice-Rector of Universidad Nacional de San Agustin University. After a small reception for the dignitaries, the station manager gave an exposition and tour of the Arequipa SLR facilities.



Figures 13-3a and b. Station Manager Presentation for U.S. Ambassador. From left seated: Mr. Paul Degler, Mr. Michael McKinley, Dionadrea Shorts, Miguel Yepez and Dr. Valdemar Medina.

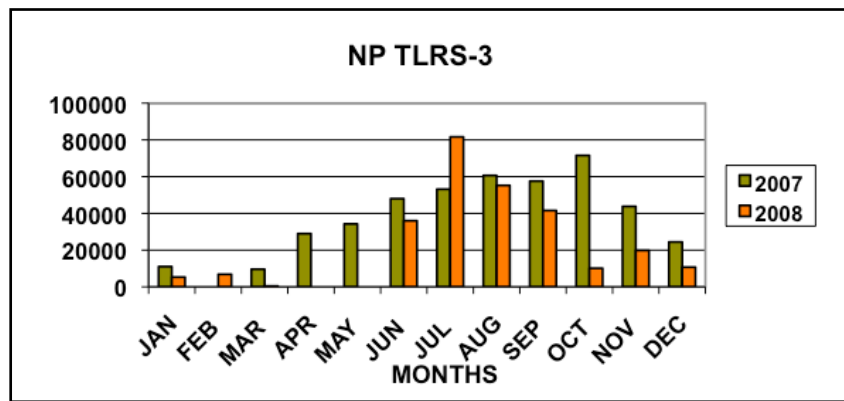

Figure 13-4. Normal points tracking totals for TLRS-3 in Arequipa.

The crew at TLRS-3 consists of Dr. Raul Yanyachi (Station Manager), Janet Caceres, Jorge Valverde, Mariano Gomez, Manuel Yanyachi, Modesto Cañari, Wilberto Cañari, Dante Corrales, Marco Higuera, and Kevynn Rodriguez.

Contact

David Carter
 NASA GSFC
 Code 453
 Greenbelt, MD 20771
 USA

Voice: 301-614-5966
 Fax: 301-286-0328
 E-mail: David.L.Carter@nasa.gov

Beijing, China

Wang Tanqiang, Qu Feng/Chinese Academy of Surveying and Mapping (CASM)

The SLR Observations

During 2007 and 2008, the Beijing SLR system (station 7249) emphasized tracking operations on all SLR satellites to which the system has the ability to reach. A total of 2,380 and 2,250 passes were obtained during nighttime operations in the years 2007 and 2008 respectively. Figures 13-5a and -5b show that data acquisition is highly dependent on the climate; observations decreased during the hot and humid summer months.

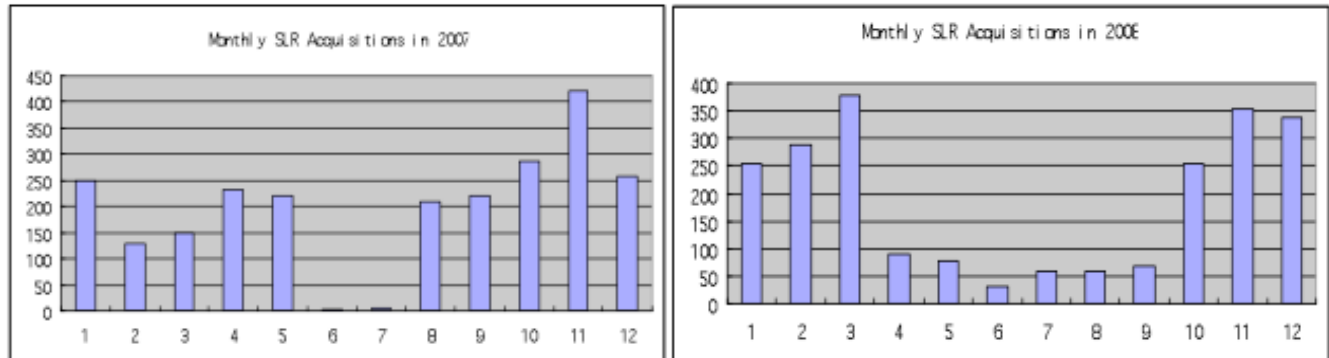

Figure 13-5a. Monthly SLR observations at Beijing in 2007 Figure 13-5b. Monthly SLR observations at Beijing in 2008

New Laser System

A new laser system (Figure 13-6) developed by the station and Beijing Industrial University (BIU) during 2006 and 2007 has considerably improved the ranging stability and performance. The system began operations with the new laser on March 26, 2007 and the quality of the ranging data for ground targets and for satellites improved immediately. During 2007, the regenerative amplifier of the new laser was installed in a sealed box. Therefore, the new laser now include three parts: the seed of a SESAM mode-locked laser imported from EOS Space Systems Pty Ltd of Australia, the flash pumped Nd:YAG regenerator developed by the Beijing station and BIU, and a two-stage flash pumped energy amplifier from the 20 year-old dye laser which was developed by North China Research Institute of Electro-optics (NCRIEO), the same manufacturer of the station's telescope. The new laser has a wavelength of 532nm, pulse width of 10ps, a single pulse energy of 30mj, and a repetition rate of 1 to 10Hz.



Figure 13-6. Beijing laser configuration.

On-Site Data Processing

During 2007 and 2008, we concentrated on the station data preprocessing software with the goal of developing an auto-processing capability. Today, the station's preprocessing programs have improved and the auto-processing has progressed smoothly for all valid data passes. Some sparse passes of data cannot be fully auto-processed, including those with good satellite data but bad ground target data. These kinds of data are typically obtained in less than ideal weather conditions.

Data Analysis Programming

Several data analysis programs have been developed in the past two years. With funding from the National Fundamental Mapping Project in 2006 and 2007, the SLR data processing and precise orbit determination software CASMORD was developed. The software structures have been modularized and include a satellite perturbation force model, data preprocessing calculations and parameter estimations, and construction of the observation model. A batch arithmetic treatment is used for calculations of station bias and station coordinates.

The CASMORD program can be used for several purposes. By quick treatment of short arc SLR data, generally a 3- or 7-day arc, estimates of global SLR station coordinates can be obtained and system bias for each station can be calculated. In addition, a quick precise satellite ephemeris and Earth rotational parameters can be computed. Precise satellite orbits, EOP, station coordinates, and station movements as well as other measurements, e.g., of the Earth's core, etc., can also be determined by precision treatment of long arc SLR data in post-processing. These products support geodynamics research. Figures 13-7a and -7b below show some results for the San Juan station, Argentina.

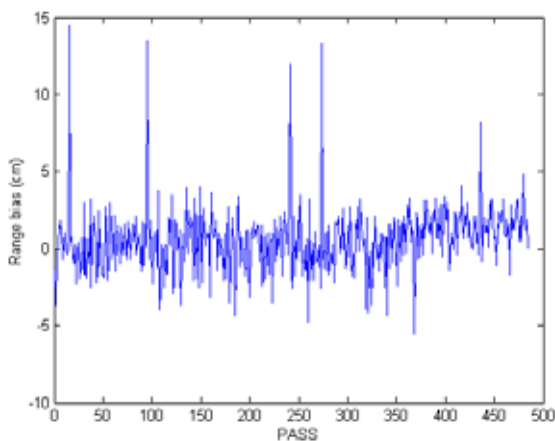

Figure 13-7a. San Juan range bias variations

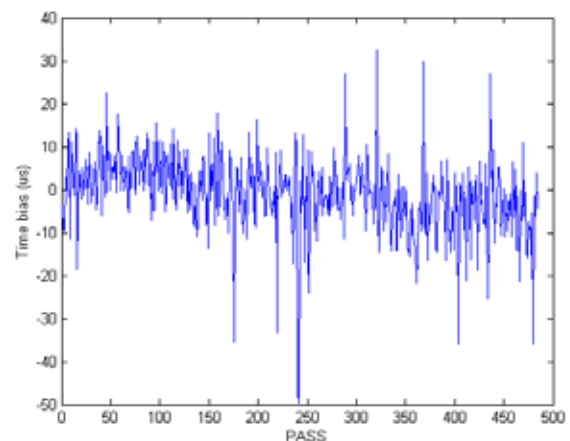

Figure 13-7b. San Juan time bias variations

Current and Future Plans

We have ordered a new laser from the High Q Laser Company of Austria to begin the upgrade of the system for a kHz ranging capability. The contract for the laser was completed last year and we expect that the laser will arrive at the station in June 2009. An A032-ET event timer for kHz operations, a set of narrow band filters from Andover Corporation in the USA for daytime tracking, and a set of steel grating encoders from Renishaw of England have been delivered and are currently being tested. The software and hardware (e.g., a range gate generator for kHz tracking) have been developed. KHz ranging and daylight tracking in Beijing station can be expected soon.

Contact

Prof. Qu Feng
Beijing Station
Chinese Academy of Surveying and Mapping (CASM)
16 Beitaping Road
100039 Beijing
CHINA

Voice: +0086-10-88217725
Fax: +0086-10-68218654
E-mail: qufeng@casm.ac.cn

Borowiec, Poland

Stanislaw Schillak/ Space Research Centre, Polish Academy of Sciences

Introduction

The Borowiec station has carried out laser ranging observations since 1993 with no significant breaks in operations. New objectives for the station, such as an increase in the number of observations through daylight tracking, improvements in the accuracy of measurements to a few mm, observations of high satellites, and one-way measurements (time transfer, lunar satellite ranging), made it necessary to implement significant changes in the SLR system. During the first stage, the laser pavilion was renovated (Figure 13-8) and an air-conditioning system was installed to ensure better operating conditions. This work was carried out from November 2006 through March 2007. In 2007, the second stage of system improvements included the modernization of the telescope's transmit and receive optical system. Stage three included installation of a new MCP-PMT detector, development of system software upgrades, and the introduction of new control computers and a new gating system. All tasks were completed in 2007 and 2008 and the process significantly restricted, or at times, prevented, regular laser ranging observations.



Figure 13-8. The Borowiec SLR building after renovation

Changes in the System During 2007-2008

The system's existing optical elements were considerably worn out and required replacement. The most important change undertaken was the recoating of the receiving telescope's main mirror (65 cm in diameter) and secondary mirror (20 cm in diameter). Another important improvement was the replacement of the five prisms in the Coudé path with dielectric mirrors and the replacement of the telescope control systems with new models, thus permitting more precise regulation of the mirrors' position. A new 10 cm diameter transmitting telescope allowed the laser beam divergence to be adjusted. Unfortunately, tests of this telescope thus far have not produced satisfactory results. The 20 cm diameter transmitting telescope previously used in the system has also been tested. The exchange of the receive package has not been completed. This package contains a new interference filter with a spectral width of 0.3 nm or 1.0 nm, a regulated space filter, and a CCD camera for control of the position of the laser beam during daylight operations.

To extend the range and to improve the effectiveness and precision of observations, a microchannel plate photomultiplier tube (Hamamatsu R5916U-64-3MCP, shown in Figure 13-9) was installed on May 29, 2008. High efficiency of the photomultiplier (QE at 30%, gain 1.5×10^6 at 532 nm) and small Transit Time Spread (TTS) should improve performance. Preliminary data indicated a large dependence in the single shot RMS on the signal strength,

both for calibration and satellite observations. For weak signals, the RMS exceeds 20 mm, which is a considerable deterioration in comparison to the 15 mm reached with the previously used photomultiplier (Hamamatsu H5023). For strong signals, the results are somewhat better. The calibration stability determined by the dependence of delay on the signal strength is within 50 ps, which is much better than experienced with the H5023 photomultiplier.

The DOS-based software used in the real-time system, which consists of two linked computers, MASTER (real-time control program) and SLAVE (input/output programs), did not provide correct system operations. Two new and faster computers were introduced using the same basic software with the possibility of a gradual introduction of the Linux operating system. A Stanford DG-535 gate generator, for gating the time interval counter and the photocathode of the photomultiplier, was added but adversely influenced the program execution times. For the photocathode gating, a regulated gate window was introduced with a range from 10 ms to 10 ns. The changes in the software did not increase the speed of the programs, while the delay introduced by the new gating system and the transmission between the computers led to fundamental problems and problems in execution. At present, efforts are underway to eliminate these problems. An additional task for the staff is to adapt the software to work with the A032-ET event timer.



Figure 13-9. MCP-PMT Hamamatsu R5916U-64-3MCP (up), photocathode gating window (right) and power supply (left).

Operations

During 2007 and 2008 the Borowiec SLR station produced, collected, and delivered 9,600 normal points to the scientific user community, tracking 673 passes on 22 satellites. The significantly lower number of passes in comparison to previous years was due to the renovation of the SLR building and modernization of the SLR system.

Future Plans

Future efforts will concentrate on the upgrade of the outdated system for telescope control, including the engines and angle encoders, which is expected to permit more accurate tracking and realization of daylight tracking. Installation of an indoor calibration system is underway. Other important tasks include the introduction of the A032-ET event timer and the implementation of the new CRD format needed for participation in the time transfer by laser link (T2L2) project.



Figure 13-10. Station control room.

Other Tasks

The Borowiec SLR Analysis Group continued orbital analysis of the SLR data, determining the positions and velocities of the SLR stations from LAGEOS data in 1993.0-2004.0. The SLR station positions and velocities were also determined from the observations of the low satellites Starlette, Stella, and Ajisai. These results are in good agreement with the LAGEOS data. The terrestrial reference frames ITRF2000 and ITRF2005 for SLR stations were compared using five years of LAGEOS data. Other tasks included comparison of station coordinates between SLR and GPS for the same stations during two epochs: 1999.0-2004.0 (19 stations) and 1993.0-2004.0 (12 stations).

In addition to the SLR system operation, the Borowiec site is a permanent IGS station (BOR1) operating with a new Trimble NetRS receiver (since July 2007). The station has a high-quality time service equipped with two hydrogen masers and two cesium frequency standards HP-5071A, a 500 ps Time Transfer System TTS-4 (produced in the Borowiec Observatory) and two-way system with an accuracy of 200 ps for time scales comparison. Gravity measurements are made with an absolute gravimeter two times per year.

16th International Workshop on Laser Ranging

The Borowiec SLR staff organized and hosted the 16th International Workshop on Laser Ranging, held on October 13-17, 2008 in Poznan. Over 140 delegates attended the workshop, giving 125 oral and poster presentations. During the week, the participants and accompanying persons visited the Borowiec Astrogeodynamic Observatory.

Contact

Stanislaw Schillak
Space Research Centre,
Polish Academy of Sciences
Astrogeodynamic Observatory
Borowiec
ul. Drapalka 4
62-035 Kornik
POLAND

Voice: +48-61-8170-187
Fax: +48-61-8170-219
Email: sch@cbk.poznan.pl
Web: www.cbk.poznan.pl

Changchun, China

Cunbo Fan Cunbo/National Astronomical Observatories, Changchun Observatory, CAS

System Upgrades

The North China Research Institute of Electro-optics (NCRIEO) loaned a new laser (shown in Figure 13-11) to the Changchun Observatory. The specifications of this laser are: active-active mode locked Nd:YAG laser, 100-150mJ in 532nm, 250ps, 20Hz



Figure 13-11. Changchun laser equipment

Additional improvements were made to the laser system including new Coudé mirrors, a 210 mm diameter transmitting telescope, a 10 arcsec laser beam adjustment for divergence, and an ET-A320 event timer. Instruments were procured for research purposes including a frequency distribution amplifier and a pulse distribution unit. Table 13-1 summarizes observed passes at the Changchun SLR station during the past two years from a subset of satellite.

Table 13-1. Summary of observation passes from selected satellites at Changchun (2007-2008)

Satellite	Number of Passes
BD-MEO (Compass-M1)	77
ETS-8	33
GIOVE-A	106
GIOVE -B	21

Changchun participated in the laser time transfer (LTT) test organized by the Shanghai SLR group. Changchun SLR observation data are routinely transmitted in both CPF and CRD formats.

Future Plans

The future plans for the Changchun Observatory include routine daylight tracking and high repetition-rate SLR operations.

KHz SLR

A high repetition-rate control system has been developed and is now operational at the Changchun SLR station. The system allows the SLR to operate at frequencies from 1 Hz to more than 2 kHz. The real-time control hardware and software runs under the Windows XP environment. The hardware control circuit includes three components: an accurate timing part, a range gate control, and a laser firing control. A 2 kHz laser, borrowed from the Wuhan SLR group, was used to function together with the control system to test the system performance. The experimental results show that the frequency fire rate control system operates very well at or less than 2 kHz.

Daylight Tracking

As was reported previously, the station's hardware and software systems were ready for daylight tracking at the end of 2005. But due to several special projects, we were not able to conduct routine daylight tracking, so research in this area continues. On May 16, 2008 at 11 a.m., we attempted our first daylight pass; the system obtained return pulses from ERS-2 (see Figure 13-12). This accomplishment shows that a breakthrough in daylight tracking has been achieved at the Changchun station.

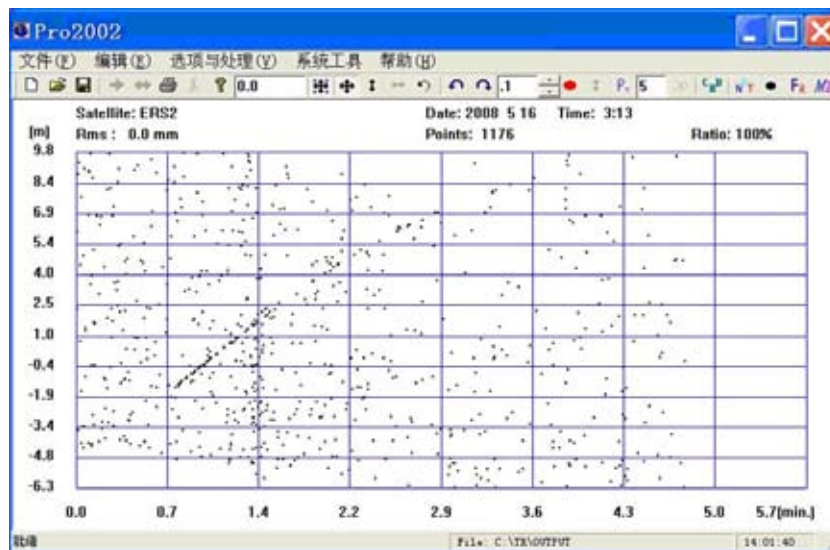

Figure 13-12. The first result of daylight tracking

SLR Data Analysis

Since the beginning of 2008, the Changchun Observatory has carried out routine short-arc (3-day) orbit determination and station residual analysis using LAGEOS SLR data. Meanwhile, we began studies in related issues, such as precise satellite orbit determination and its preliminary applications. We have obtained short-arc orbit determination accuracy around 1.2 cm with moderate differences. Therefore, Changchun Observatory now has a foundation in SLR POD analysis. Routine POD and residual analysis results on LAGEOS-1 and -2 are available from the Changchun station website.

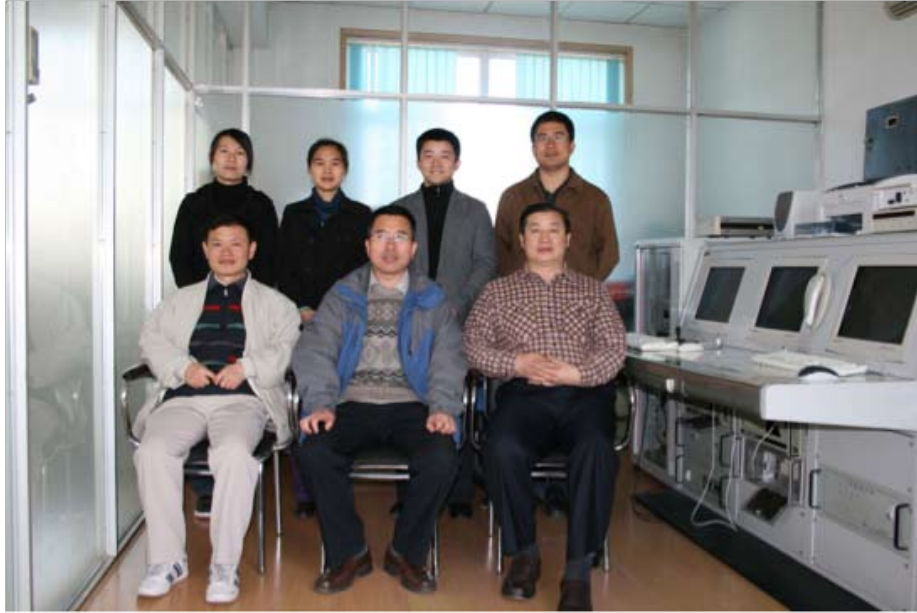

Figure 13-13. The Changchun SLR Station staff (left to right): Song Qingli, Dong Xue, Zhang Zi'ang, Han Xingwei, Fan Cunbo, Liu Chengzhi, Shi Jianyong.

Contact

Fan Cunbo
Changchun Observatory
National Astronomical Observatories
Chinese Academy of Sciences
Jingyue Lake Changchun
130117, Jilin
CHINA

Voice: 86-431-84511337
E-mail: fanchb@cho.ac.cn
Fax: 86-431-84512722

Concepción, Chile

Bernd Sierk/BKG

In 2007 and 2008 the Transportable Integrated Geodetic Observatory (TIGO) SLR station completed its performance improvements after the upgrade to a new 100 Hz, passively (SESAM) mode locked titanium:sapphire laser system in 2006. Several projects have been carried out to further improve the station's hardware and software infrastructure. Most notable was a fundamental maintenance service of the laser telescope performed during August and September 2008. The four large prisms folding the beam in the Coudé path had degraded over several years of continuous operation in harsh conditions and had to be replaced. The implementation of the repair service, carried out on site in absence of service infrastructure and buildings, involved the replacement of these prisms and their mounts within the hermetically sealed optical Coudé train. Quasi clean-room conditions equipped with air conditioning and filtering devices were established by the construction of two interleaved tents around the site. The entire telescope structure had to be lifted to access and replace the prisms, requiring a complete re-alignment and survey of the instrument afterwards. The photos below give an impression of the fieldwork required, which was successfully completed in early October 2008.



Figure 13-14. Photos taken during the replacement of the beam guiding prisms of the Coudé telescope. Upper left: Removal of a prism underneath the two-ton telescope. Upper right: Replacement of a prism mount.

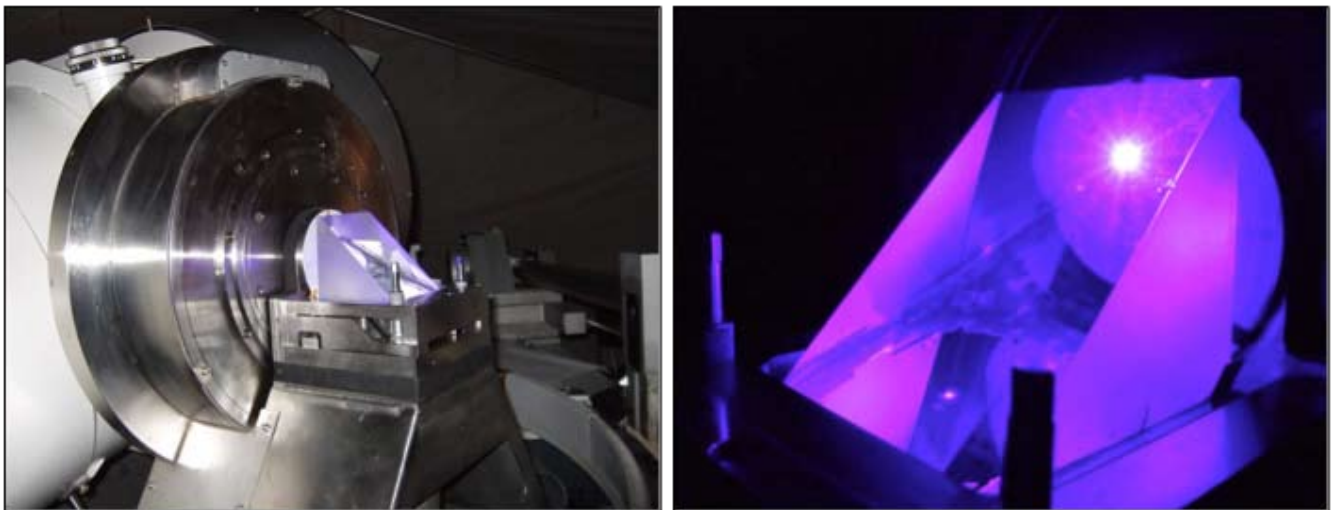

Lower left and right: Re-alignment of the transmission beam in the elevation axis.

The renewal of the critical telescope components resulted in a significant increase in data productivity, which is also reflected in the monthly observation statistics plotted in Figure 13-15. In particular, the system’s performance in ranging to HEO satellites (GNSS and Etalon) has increased significantly after the maintenance performed in October 2008. The station now ranks among the most productive stations of the ILRS network during the summer months in the Southern hemisphere. The impact of the winter rainy season (which was particularly intense between May and August 2008) is also clearly visible in the time series.

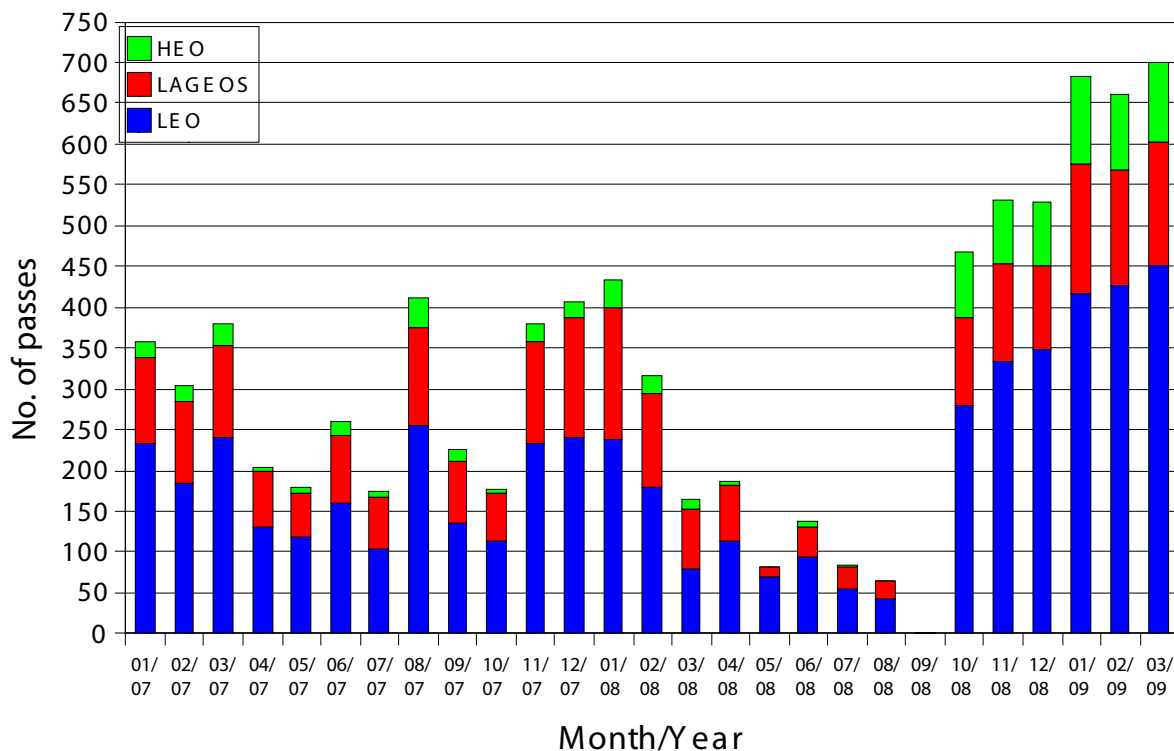

Figure 13-15. Number of passes per month from 2007 through March 2009.
 Note the increase in data productivity after the telescope maintenance in August/September 2008.

The most important change for the station’s daily operations was the addition of six student observers in late 2007. This change in the personnel structure became necessary after the departure of the University of Bio-Bio from the Chilean consortium supporting TIGO, which left two engineer positions unfilled. The new observers were trained by the core staff of four Universidad de Concepción engineers and are now successfully supporting 24-hour/7-day operation since early 2008.

There are several projects under further development at the Concepción laser station. It is expected to resume two-color operation by mid-2009 and several experiments for signal propagation studies are planned. TIGO’s SLR team, depicted in the photo in Figure 13-16, is also looking forward to hosting the 17th International Workshop on Laser Ranging in Concepción in November 2010.



Figure 13-16. The TIGO- SLR team (left to right): Alejandro Fernández, César Guaitiao, Bernd Sierk, Malgorzata Kolaczowska, Marcos Avendaño, Yazmina Olmos, Felipe Pedreros, Víctor Mora (and Maxi the dog). Not in the photo: Manuel Bravo and Anatoli Poliak.

Contact

Dr. Bernd Sierk
Bundesamt für Kartographie und Geodäsie
Observatorio Geodesico TIGO
Universidad de Concepción
Concepción
CHILE

Voice: +56-41-2207035
Fax: +56-41-2207031
E-mail: sierk@tigo.cl

FTLRS, France

Francis Pierron/Observatoire de la Cote d'Azur

The FTLRS staff consists of F. Pierron, D. Feraudy, M. Furia, M. Pierron, M. Laplanche, J.M. Torre, F. Para, and J.C. Poyard (IGN).

Recent Activities

Cal/Val Campaign in Tasmania

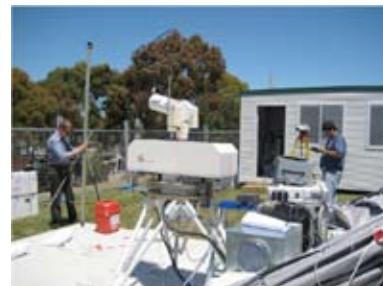
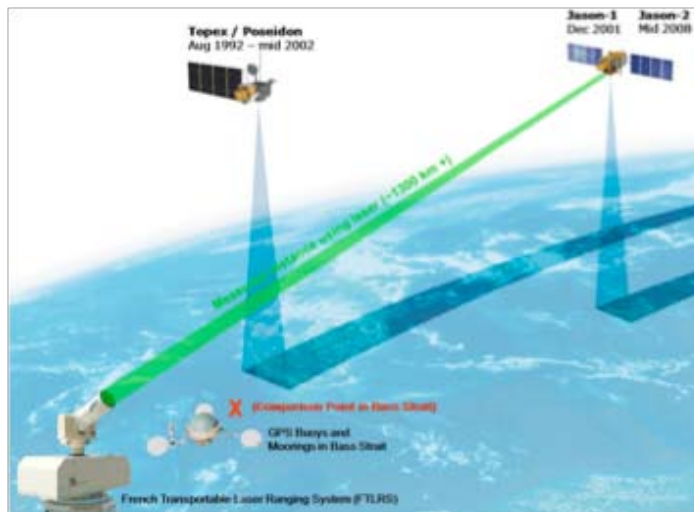

Figure 13-17. Jason cal/val experiment.

Figure 13-18a. OCA staff members in Tasmania: Francis Pierron, Maurice Furia, and Maurice Laplanche (left to right).

Figure 13-18b. FTLRS setup in Tasmania (December 2007); Chris Watson/University of Tasmania at Hobart (left) Paul Digney/Department of Primary Industries, Parks, Water and Environment, Tasmania (right).

FTLRS was deployed to Burnie Tasmania from December 2007 through April 2008 in support of the Jason-1 project. This activity was a collaboration between The Observatoire de la Côte d'Azur (France) and Australian partners, the University of Tasmania, the Australian National University, and Geoscience Australia as part of the AuScope Project. AuScope is an initiative of the Australian Government conducted as part of their National Collaborative Research Infrastructure Strategy. The Australian scientists supporting the Tasmanian campaign were R. Coleman, C. Watson, P. Tregoning, and J. Zhang.

The participating agencies contributed various tasks to support this project:

- Contribution of OCA:
 - o Use of FTLRS (with the exception of operation costs)
 - o Salaries of OCA technical teams for installation
 - o Equipment maintenance and operations
- Contribution of hosting laboratory (additional expenses):
 - o FTLRS transportation and infrastructure expenses (setup)
 - o Transportation and mission fees for technical staff

- o Operational costs
- o Hardware maintenance (optic, flash, Yag rods, etc.)
- o Consumables, communications, etc.
- o Shelter installation

The results obtained from the Burnie occupation are:

- Total passes: 673 on Jason, ERS-2/Envisat, Stella/Starlette, LAGEOS-1/-2
- Total normal points: 9,200
- Bias and stability: 1/2 mm level with Stanford model
- Number of OCA employees: eight engineers for operations
- Number of Australian employees: Hobart and Canberra scientists plus one post-doc

Other Occupations

FTLRS traveled to Ajaccio, Corsica for a Jason-1/-2 cal/val campaign (July through December 2008). The calibration passes acquired during the tandem mission are shown in Figure 13-19.

FTLRS Upgrades

FTLRS was upgraded to support the T2L2 experiment on Jason-2. The main upgrade was the installation of a Dassault event timer, which required both hardware and software engineering support.

First T2L2 results : Ftlrs at Grasse & Ajaccio with MEO at Grasse July 2008 on Jason2 some days after launch



Figure 13-19a. T2L2 experiment supported by FTLRS and Grasse MEO station

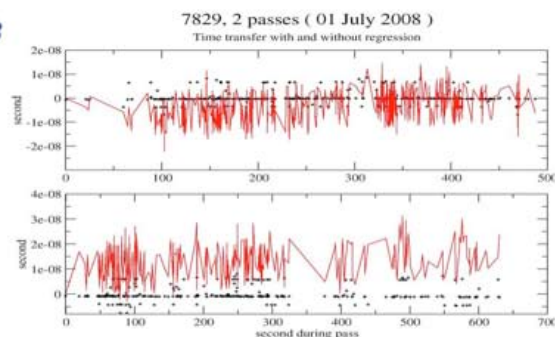

Figure 13-19b. FTLRS Jason-1/-2 cal/val campaign results in Corsica July-December 2008.

Contact

Francis Pierron
Observatoire de la Côte d'Azur, CNES/GRGS
Avenue N. Copernic
06130 Grasse
FRANCE

Voice: 33 493405420
Fax: 33 493092614
E-mail: francis.pierron@obs-azur.fr

Grasse, France

Etienne Samain/Observatoire de la Cote d'Azur

At the beginning of 2004, a new organization was set up at the Observatoire de la Cote d'Azur (OCA). In this framework, the Lunar Laser Ranging (LLR) portion of the Grasse facility was modified in order to give the station the capability to track both low and high altitude satellites. The LLR station is now renamed MeO for Metrology and Optics. Satellite acquisitions that were previously performed by the Grasse SLR station are henceforth done by MeO.



Figure 13-20. Grasse MeO station.

Several developments were undertaken on the telescope, the dome, the Coudé path, the software, and the monumentation. All work was completed by the end of 2008. First echoes in the new configuration scheme on both low and high altitude satellites were obtained in July 2008.

As compared to the previous design, the objective of the system modifications was to increase both the speed and the acceleration of the telescope by one order of magnitude to get a speed of $5^\circ/\text{s}$ and an acceleration of $1^\circ/\text{s}^2$. This goal has been achieved with some direct drive motors (Etel) and some direct encoders (Heidenhain), shown in Figures 13-21a and -21b. The diameter of each motor is 1 meter; they can produce a torque of up to 1000 kg/m.

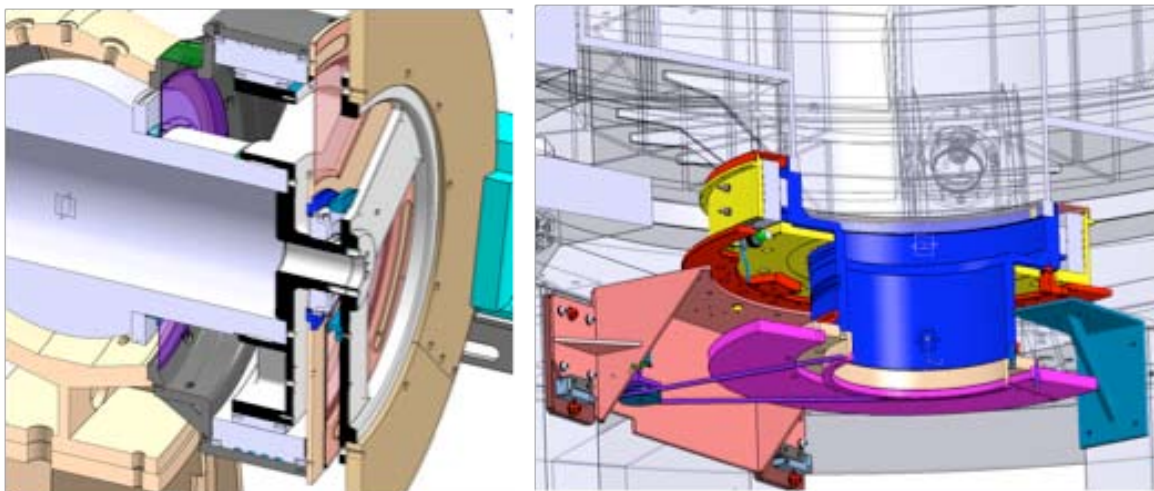

Figures 13-21a, -21b. Diagrams of Etel direct drive motors and Heidenhain encoders.

The pointing accuracy is corrected through a calibration process based on a six-order harmonic decomposition model using a table of 48 stars. The dome was also redesigned to get the same speed performances. This goal was achieved with a circular rail attached on the wall, and 10 guiding modules maintained by springs for both the vertical axis and the radial axis. The motorization is made with asynchronous motor drives in frequency.

There are now two laboratories linked to the telescope (Figures 13-22a and -22b). The first one, dedicated to research and development, is based on a 60 mJ circular room located under the telescope and centered on the azimuth axis of the telescope. The second one, for operational laser ranging activities is located six meters from the azimuth axis. It has a surface of 45 mJ. This laboratory was built around a single large optical bench for both laser and reception unit. This architecture uses the same Coudé optical path for both emission and reception. The laser has two cavities, one for the Moon (200 ps 300 mJ), the other one for satellites (20 ps, 50 mJ). Currently, the detection unit is located on the Nasmyth bench. It will be installed in the final operational lab by the end of 2009



Figures 13-22a, -22b. Research and development laboratory and operational telemetry laboratory.

The Coudé path is made with 200 mm Zerodur dielectric mirrors. The bandwidth is between 350 to 1200 nm with a reflection factor higher than 98% for both s and p polarizations.

Contact

Etienne Samain
Observatoire de la Côte d'Azur
2130 Route de 'Obs
0460 Caussols
FRANCE

E-mail: etienne.samain@obs-azur.fr

Graz, Austria

Georg Kirchner, Franz Koidl/Austrian Academy of Sciences

The kHz SLR System in Graz – Upgrades During 2007 and 2008

Several upgrades have been implemented in 2007 and 2008, both in hardware and in software. The field programmable gate array (FPGA) based PC board (Figure 13-23), developed and used by the Graz SLR station, has been upgraded again, replacing now two obsolete digital boards and offering new features. The board measures start and stop event times with sub-ns resolution (RMS: 250 ps) to allow for fast range gate settings (within a few μ s after e.g., a start event). This capability is especially important for very low orbiting satellites like GOCE, which require range gate settings within less than 1 ms after laser fire; our high resolution and high precision event timer (Graz ET), which is used for high accuracy epoch time determination, needs more than 0.4 ms to do that.



Figure 13-23. FPGA board.

Other upgrades within the FPGA now allow full use of the integrated 64 bit serial buses for digital I/O; this in turn allows fully automatic control of field-of-view, laser beam divergence settings, laser beam pointing control, receive energy control, etc.

For spherical passive satellites, like Ajisai and LAGEOS-1/-2, we derived a new post-processing scheme, to achieve mm accuracy regardless of the cm target signatures. Basically, we accept only returns from the nearest retro-reflectors, and only until a “reflection depth” of 20 mm maximum (see the 2008 presentation from the 16th International Workshop on Laser Ranging for details).

One of our main scientific results was the determination of spin parameters. We were able to determine spin periods of Etalon-1 and -2 (Figure 13-24); this is especially remarkable regarding their high orbits ($> 20,000$ km), which gives less than 0.1% average return rates. Nevertheless, comparing simulated and measured SLR data of these two identical satellites, we used the gaps between the different sets of retro-reflectors to derive the spin periods for last three years. In addition, we derived a complete spin history for both LAGEOS (15 years) and Ajisai (22 years).

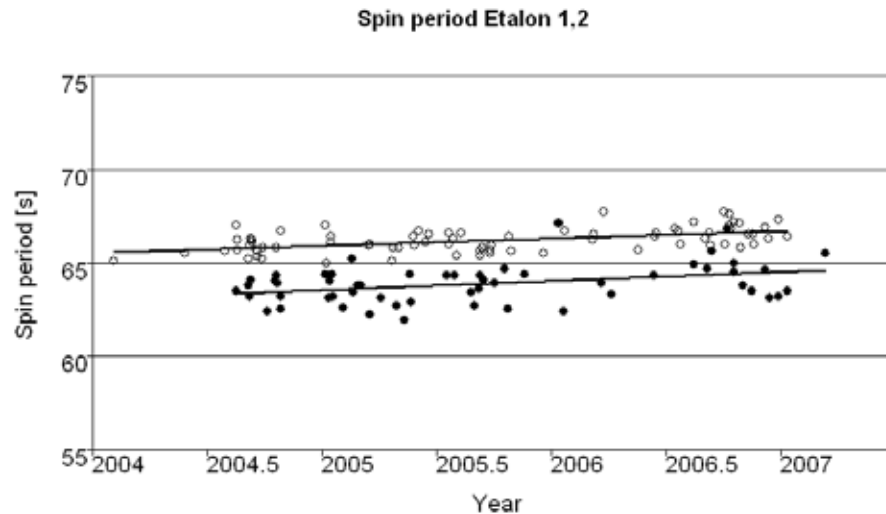

Figure 13-24. Etalon-1 and -2 spin period determinations.

We initiated several other projects, mainly to use the SLR station equipment during observation gaps, and/or as side effects:

- We are implementing a LIDAR system into the SLR station, using the backscatter of the transmitted laser beam to determine haze, clouds, vapor trails, atmospheric layers etc. as a side effect during any SLR activity.
- The laser beam pointing deviations due to atmospheric seeing are continuously monitored during night SLR measurements; the seeing values are evaluated and stored automatically.
- As part of a diploma requirement, we measured photon flux variations of eclipsing binary stars, using Single-Photon-Counting-Modules.

The entire observatory building was completely refurbished; the newly added thermal isolation has excellent effects on all our rheumatism symptoms (and on atmospheric seeing: we are now no longer heating the atmosphere). A new dome was installed (see Figures 13-25 and 13-26), which is now automatically operated via the real-time laser PC, proving to be one of the best investments during these years.



Figure 13-25. Dome replacement work.



Figure 13-26. The new Graz SLR Observatory dome.

Contact

Dr. Georg Kirchner
Austrian Academy of Sciences
Department of Satellite Geodesy
Lustbuhelstrasse 46
A-8042 Graz
AUSTRIA

Phone: 43-316-873-4651
Fax: 43-316-873-4641
E-mail: Georg.Kirchner@oeaw.ac.at

Greenbelt MD (MOBLAS-7), USA

David Carter/NASA GSFC, Julie Horvath and Scott Wetzel/HTSI



Figure 13-27. MOBLAS-7 in Greenbelt, MD.



Figure 13-28. MOBLAS-7 staff (left to right): William Weaver, Robert Hicks, and Maceo Blount.

In 2007 and 2008, MOBLAS-7, under the supervision of Maceo Blount, supplied SLR tracking from the Goddard Space Flight Center (GSFC) in Greenbelt, Maryland, for its 25th and 26th years of operation at the site.

MOBLAS-7, as the engineering standard for the NASA laser ranging network, was the testbed for all of the major upgrades for the NASA SLR systems during 2007 and 2008. Several major improvements to the NASA SLR stations were developed at MOBLAS-7 where HTSI engineers perfected system improvements and finalized installation techniques. At the same time, HTSI coordinated the training of new crew members, William Weaver and Robert Hicks, at MOBLAS-7 for preparations for the Next Generation SLR (NGSLR) operations in support of one-way ranging to the upcoming Lunar Reconnaissance Orbiter (LRO) mission. This training enabled the new crew members to familiarize themselves with an SLR operational system, but had the added benefit of increasing the operational hours at the MOBLAS-7 system. Furthermore, the training periods enabled the system to maintain its high quality core station status in the ILRS, and increase the amount of passes during these years with a total of over 127,500 normal points.

In 2007, HTSI engineer Mr. Tom Oldham, began a months-long development project at MOBLAS-7, designed for installation at all of the NASA SLR systems, to increase laser stability, reduce system maintenance time and costs, and eliminate on-site hazardous chemicals, by replacing the Flowing Dye Cell with a Crystal Saturable Absorber. During the installation, the laser table was completely stripped and rebuilt. The system optics were then inspected, cleaned, replaced as necessary, installed, and aligned. The system was brought on-line as a highly stable laser requiring minimal interaction to maintain oscillator stability. This engineering test achieved all of the project goals and enabled the HTSI team to verify that the system was not only useable, but also highly effective. The new saturable absorber upgrade was approved for installation at all of the NASA SLR systems, and in fact, was installed into MOBLAS-4 by the end of 2008.

At the end of 2007, HTSI software engineer Michael Heinick began his benchmark testing of the new real-time controller computer subsystem at MOBLAS-7. The existing on-site controller computer system on the NASA SLR systems (last updated in the early 1990's) had begun regularly failing throughout the NASA network, while all remaining spares and spare parts were quickly depleted. At the same time the software, as well as the new ILRS data format requirements, were tasking the computers beyond their capability. NASA made the decision to replace the obsolete ISA technology systems with a PCI bus computer including an upgraded real-time operating system, and

a new CAMAC controller, serial card, and timing card. The system greatly improved real-time operations, system stability and speed, and added much needed data storage capacity. By the beginning of 2008, the engineering tests were completed at MOB LAS-7 and the controller computer subsystems were configured for installation at all other MOB LAS systems in the network. By the end of 2008, all NASA SLR systems, except for MLRS and TLRS-3, were operating with the new technology.

In 2008, MOB LAS-7 was also used as the testbed for the upgraded processor computer system. The NASA SLR processor computers were very old systems that had out-lived their expected lifetime. With new ILRS data formats for both predictions and SLR data, the systems were not able to keep up with the upgraded software demands. The new computer system enabled MOB LAS-7 to download and process predictions, and process SLR data at very high rates of speed, without interfering with normal operations. It also enabled the crew to store and backup large amounts of SLR data for future needs. All NASA SLR systems will have the new processor computer systems by the end of 2009.

Contact

David Carter
NASA GSFC
Code 453E-mail:
Greenbelt, MD 20771
USA

Voice: 301-614-5966
Fax: 301-286-0328
David.L.Carter@nasa.gov

Greenbelt MD (NGSLR), USA

Jan McGarry/NASA GSFC



Figure 13-29. NGSLR staff (left to right): Tony Mallama, Tom Cuff, Loyal (Stu) Stewart, Tom Zagwodzki, Jack Cheek, Don Patterson, Jan McGarry, Jim Long, Mike Perry, Tony Mann, Renata Barski, Bud Donovan, John Hundertmark.

NGSLR advanced towards completion of its SLR capability during 2007 and 2008. The Risley Prism point-ahead of the transmit beam was successfully completed allowing the closure of the receiver field of view down to 11 arcseconds. This in turn made daylight ranging possible. Daylight ranging up to LAGEOS altitudes became routine during this period. Improvements in the Pulse Repetition Frequency (PRF) control, the alignment technique, the beam expander, and a new I/O chassis allowed routine hands-off tracking of satellites from LEO to LAGEOS and easy ground calibration capability. Although the system's Q-Peak laser energy gradually decreased to less than 80 microJoules per pulse, the ability to set the laser divergence to 4 arcseconds, combined with very accurate predictions and arcsecond level mount control, gave the system the ability to track LAGEOS down to 20 degrees elevation and successfully track GLONASS.

Future efforts will concentrate on co-location of the system with MOBLAS-7 and completion of the automated closed-loop tracking.

During this period modifications to NGSLR for laser ranging to LRO were implemented. A 28 Hz, 50 milliJoule per pulse Northrop-Grumman laser was added to the system, along with a removable mirror to allow the system to use either the Q-Peak (2 kHz eyesafe SLR) or the Northrop-Grumman (LRO) laser. Since the new 28 Hz laser is not eyesafe, an aircraft avoidance radar was also added to the system. Software and I/O chassis changes were also made to implement laser ranging to LRO.

Contact

Jan McGarry
NASA GSFC
Code 694
Greenbelt, MD 20771
USA

Voice: 301-614-5867
Fax: 301-614-6015
E-mail: Jan.F.McGarry@nasa.gov

Haleakala HI, USA

Daniel O'Gara/University of Hawaii Institute for Astronomy



Figure 13-30. Night Operations at Haleakala

After achieving “first light” on October 23, 2006, TLRS-4 at Haleakala has continued the impressive results that were achieved during engineering tests performed at GSFC prior to deployment.

HTSI completely refurbished the system at GSFC in 2005-2006, installing all the latest hardware and software used by the other NASA funded/affiliated systems. The system was moved to the summit of Mt. Haleakala in September 2006.

Within a few months of the move to the Haleakala Observatories, TLRS-4 was producing quality data on targets up to LAGEOS orbital heights. Because of the location of TLRS-4 on the summit of a 10,000-foot mountain, results from LAGEOS were quantitatively better than other deployment locations of the system. TLRS-4 can routinely track LAGEOS at a minimum tracking elevation of 20 degrees, which had always been difficult at the lower elevations of previous deployments.

Night operations commenced in early 2008. TLRS-4 is currently scheduled to operate seven days a week, with a total of 80 hours of operations per week covered by two shifts. Half of this time is dedicated to nighttime operations.

The possibility of tracking HEO targets was realized with the acquisition of GLONASS in early 2007. GLONASS tracking was successful even in daylight hours. We have experienced some difficulty with the results due to the implementation of 4 Hz tracking (which was an upgrade done by HTSI specifically to take advantage of the high altitude location). No GLONASS data have been released yet, but we hope to have the problem resolved shortly so TLRS-4 can add HEO targets to its regular schedule of supported missions.

Craig Foreman and Jake Kamibayashi conduct daily tracking operations. Rikki Kaia and Vivian Kamibayashi fulfill mount observation duties.



Figure 13-31. Jake Kamibayashi (left) and Daniel O'Gara at TLRS-4.

Contact

Dan O'Gara
University of Hawaii Institute for Astronomy
34 Ohia Ku
Makawao, Hawaii, 96768
USA

Voice: +1-808-573-9505
Fax: +1-808-573-9557
E-mail: ogara@ifa.hawaii.edu

Hartebeesthoek, South Africa

Ludwig Combrinck, Johan Bernhardt/HartRAO

The MOBLAS-6 satellite laser ranging system (Figure 13-32) has been active at Hartebeesthoek Radio Astronomy Observatory (HartRAO) since June 2000 in collaboration with NASA.



Figure 13-32. MOBLAS-6 at HartRAO.



Figure 13-33. The MOBLAS-6 station crew (from left to right): Ludwig Combrinck (Space Geodesy Programme Manager), Johan Bernhardt (Station Manager), Willy Moralo (Operations Supervisor), Christina Botai (Student) and Sammy Tshetu (Operator).

History

During the last eight years, the MOBLAS-6 system has supplied high quality satellite laser ranging data from Hartebeesthoek, South Africa. Data volume and quality increased significantly during the first year of operations bringing MOBLAS-6 in line with the SLR global leaders.

We have noticed a decline in data volume over the past two years as a result of degradation in atmospheric conditions at HartRAO, in terms of cloud cover and pollution. A site survey at Matjiesfontein (semi-desert region) suggests a much more suitable location for satellite laser ranging in South Africa.

2008 Laser Upgrade

During late 2008, the MOBLAS-6 laser was upgraded with the support of Thomas Oldham from Honeywell STI. This opportunity was also used to perform a detailed inspection, which included the repair and service of all optical components used in the laser system to the extent that we had to remove all the optics from the laser table. The laser table layout was also affected by this upgrade and, in short, we basically had to rebuild the laser from scratch again. This resulted in a much more stable and reliable laser system.

Additional system upgrades were performed:

- New UPS installed
- Walkway refurbished, new safety rails and signs installed
- New CCTV systems installed
- New operating computer and software upgrade

The MOBLAS-6 Ranging Capability

- Day-time ranging: low and medium orbit satellites
- Nighttime ranging: low, medium and high orbit satellites
- Operating shifts: 24-hour 5-day and 8-hour 2-day per week

Contact

Dr. Ludwig Combrinck
Associate Director: Space Geodesy
Johan Bernhardt
Manager, MOBLAS-6
Hartebeesthoek Radio Astronomy Observatory
P.O. Box 443
Krugersdorp, 1740
SOUTH AFRICA

E-mail: ludwig@hartrao.ac.za
E-mail: ludwig@iisgeo.org
E-mail: johan@hartrao.ac.za
Voice: +27 12 326 0742
Fax: +27 12 326 0756
Web: <http://hartrao.ac.za>

Helwan, Egypt

Makram Ibrahim, Magdy El-Saftawy, Makram Ibrahim Khalil Ibrahim/NRIAG

The Helwan SLR station operates under the cooperation of the National Research Institute of Astronomy and Geophysics (NRIAG) Helwan, Egypt and the Czech Technical University, FNSPE, Czech Republic. The station is part of the Space Research Laboratory of the NRIAG. According to the ILRS global performance report card, there were 54 and 21 observed satellite passes during the years 2007 and 2008 respectively. During the past two years, a few modifications have been made to the station:

- The roof of the station was motorized to permit opening and closure of the roof through remote control.
- The exterior of the building was modified resulting in an improvement in the appearance of the station.

Figures 13-34 a-c show the station building following construction, a satellite observation, and the oscilloscope output.



Figure 13-34 (a-c). External view of the Helwan station; satellite observations at night; the shape of the semi-train laser pulses, as measured by the oscilloscope.

Station Staff

- Associate Prof. Dr. Makram Ibrahim, Head of the Helwan SLR station
- Associate Prof. Dr. Khalil Ibrahim Khalil, Head of Space Science Laboratory
- Mr. Hany Mahmoud Mohamed, assistant researcher
- Mr. Mohamed Yehya, researcher assistant (now working in Saudi Arabia)
- Mr. Sami Ahmed Fath-allah, technician
- Mahmoud Mostafa, assistant researcher engineer (new staff member)

Personnel from the Czech Technical University work with the Egyptian staff at the Helwan station on maintenance and upgrade activities. The Czech Technical University staff members are Prof. Dr. Miroslav Cech, Prof. Dr. Antonin Novotny, Prof. Dr. Helina Jelinkova, Prof. Dr. Ivan Prochazka, Dr. Josef Blazej, Dr. Petr Matlas, and Eng. Jan Stoklasa.



Figure 13-35. Members of the Helwan SLR Station staff (clockwise from left) Mr. Mohmmmed Yehya, Dr. Makram Ibrahim, Mr. Sami Fath-allah, Dr. Helina Jelinkova, Mr. Hany Mahmoud, and Dr. Miroslav Cech.

Helwan Station Upgrades

A software package has been designed, written, and debugged for implementation of the Consolidated Prediction Format (CPF). The package was designed in such a way that the code and files could be added to the existing prediction and data analysis package that is based on the inter range vectors (IRV) prediction format. The main functions of the software package are:

- Input ephemeris, data file manipulation
- Satellite position prediction, tracking data for SLR station on-line control, generation of standard tracking data file
- Interactive procedure for computation of satellite position and range for given epoch
- Post passes data analysis by means of orbital data fitting

Future Upgrades and Extended Cooperation

Routine operations at the Helwan SLR station will require many spare parts, equipment, and modifications, in order to increase the efficiency of the laser ranging to reach satellites at higher altitudes and to extend the range of satellites observed by this system. For that reason a new memorandum of understanding of cooperation between the National Research Institute of Astronomy and Geophysics (NRIAG) and the Czech Technical University in Prague Faculty of Nuclear Sciences and Physical Engineering (CTU FNSPE) has been established. The period of the memorandum of understanding will be five years. The following scientists will be responsible for this inter-agency cooperation: Dr. Makram Ibrahim and Dr Khalil Ibrahim (from the Egyptian side) and Dr. Josef Blazej, and Dr. Antonin Novotny (from the Czech Republic side).



Figure 13-36(a-d). Dr. Makram Ibrahim, Dr. Khalil Ibrahim, Dr. Josef Blazej, and Dr. Antonin Novotny.

Contact

Dr. Makram Ibrahim
NRIAG
Space Science Laboratory
11421 Helwan, Cairo
EGYPT

Voice: +201 05799722
Fax: +202 5548020
E-mail: makram@nriag.sci.eg
E-mail: makikh@yahoo.com

Herstmonceux, UK

Graham Appleby, David Benham, Philip Gibbs, Christopher Potter, Robert Sherwood, Toby Shoobridge, Vicki Smith, Matthew Wilkinson/
NSGF

Introduction

During this period we have worked at the NERC Space Geodesy Facility (SGF) towards full implementation of an SLR system that can be changed rapidly under computer control between 10Hz and 2kHz rates. The software and hardware are now in place for this, but progress towards an operational and reliable kHz system was hampered until recently by a number of problems with the laser that resulted in frequent damage to optical surfaces. These problems have now been resolved, and the two-laser facility is fully operational. The decision to maintain this two-laser capability has proven correct as the kHz laser continues to achieve only very low return rates, such that, in particular, daytime ranging to LAGEOS and higher is extremely difficult. Link-budget calculations suggest that in practice the return rates are down relative to expectations by up to an order of magnitude at times. In response, a thorough evaluation of internal system losses is underway, to include measurement of losses at mirror surfaces, through the beam expander, etc. In parallel, an investigation into the use of fast optical filters and the possible use of an MCP detector was carried out (Wilkinson, 2008). Partly in an attempt to quantify the atmospheric losses at this low-elevation site, we are developing a LIDAR system to collect quasi-simultaneous backscatter data when ranging. Operation of the two IGS GNSS receivers continues, as does the FG5 absolute gravimeter.

Satellite Laser Ranging

Event timer

Since February 2007, the SGF has used the HxET event timer, which at that time replaced the SR620 counters that had been in use since 1993. As can be seen from the ILRS plot in Figure 13-37, this change has improved the single-shot precision of the system from an average of about 10mm to an average of about 7mm. The use of an event timer was of course essential in the move to kHz repetition rates, and using that laser, with its very short (10ps) pulse-width, again improves the single-shot precision (to 3mm).

Stanford counters

A further major advantage of using the event timer is the possibility to measure and thus remove the non-linearity inherent in the SR620 counters, particularly in calibration measurements. However, attempts to back-calibrate the SR620 by collecting simultaneous data from HxET and SR620 were not as successful as we would like but we did obtain values for back calibrating the Herstmonceux data from 1993-2007 as part of the re-analysis of SLR data from 1983. More details of this work, including references to publications, are given in the SGF Analysis Center report elsewhere in this publication.

Two-laser system

Most of the development work during the period has focused on integrating both lasers, the 'old' YAG 10Hz system and the modern VAN 2kHz laser, including the ability for the observer to switch rapidly (in about 20s) between the two as conditions and missions dictate. Note that LRO, and T2L2 on Jason-2 require use of the 10Hz laser, the latter to ensure sufficient energy for the onboard detectors to measure. The two lasers are positioned in the laser room at 90° to each other and a computer-controlled mirror positioned at the entrance to the Coudé path is moved to select the required laser. All the controls and safety features of the lasers go into a single electronics box, which then communicates with the appropriate laser.

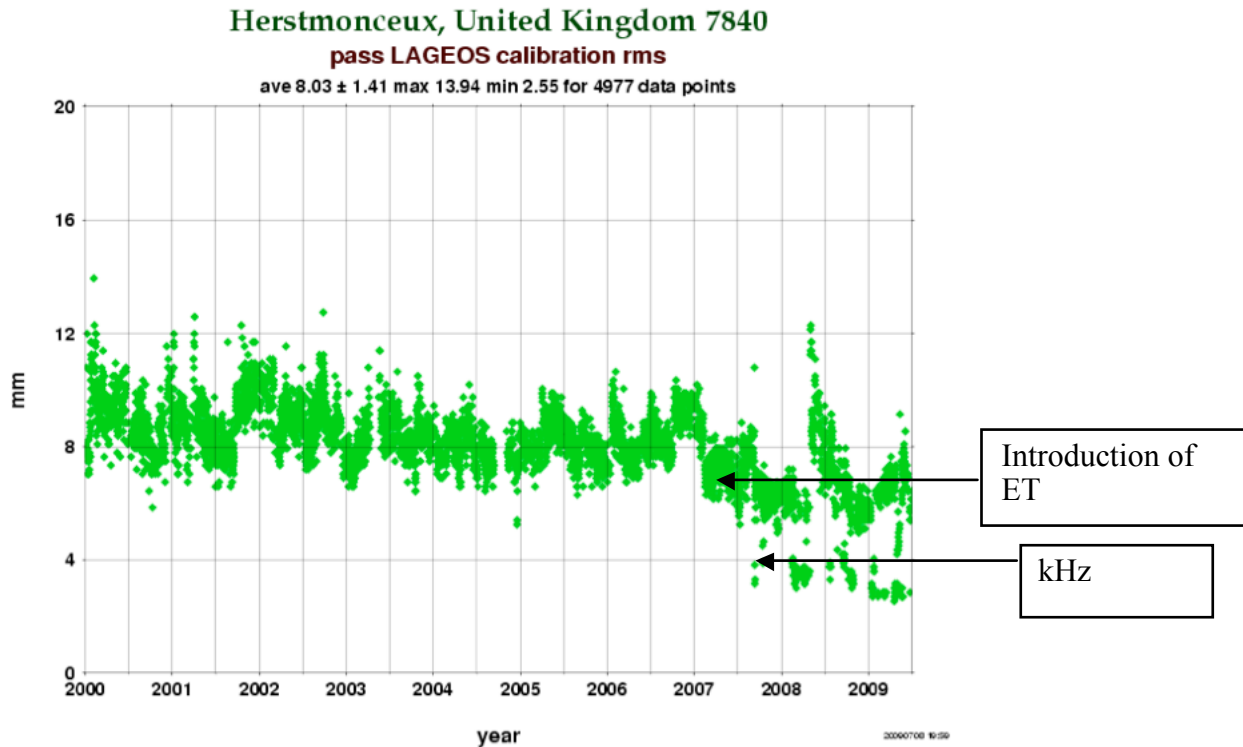

Figure 13-37. Herstmonceux LAGEOS calibration RMS.

LRO-LR

SGF responded to the NASA LRO-LR Call for Participation by submitting an application to provide ground station tracking support in synchronous mode using the YAG laser running at 14Hz. Our application was successful, and a written agreement has been signed by representatives from the NASA LRO-LR Project and the SGF. The station software to enable this support, including use of the new CRD laser ranging data format, has been written and tested successfully in collaboration with Jan McGarry from GSFC and the LRO-LR Project.

One-way epoch calibration

In order to refer observational epochs to the times that the laser pulses pass through the telescope fiducial point, a detailed set of measurements were carried out, including estimates of electronic delays and measured path lengths. The work, also applicable to T2L2 Jason-2 ranging, was reported at the 16th LR Workshop in Poznan, Poland in 2008 (Shoobridge and Benham, 2008). The estimated uncertainty of the result is of order 1ns.

GNSS

The two IGS stations (HERS and HERT) continue routine operations. The HERT GPS/GLONASS receiver was upgraded in 2007 from an Ashtech Z18 to a Leica GRX GG Pro; this receiver continues to stream navigational data into the Internet in support of both the EUREF and IGS real-time projects. In addition, we recently accepted delivery of one of the Ordnance Survey British Isles ‘backbone’ GeoNet receivers. We have also been investigating the GPS-derived baselines between the HERS and HERT and have detected a 2mm, close-to-annual term as well as a very small slope of about -0.4 mm yr⁻¹. To try to understand these features we have been running a third receiver, the old HERS Z18 GPS/GLONASS unit, between the two and are analyzing baselines between all three devices.

Gravimetry

The FG5 absolute gravimeter has been collecting regular one-day per week, 24-hour data during this period. The instrument also took part in an AG inter-comparison meeting in Luxembourg at which 19 AGs collected simultaneous data for comparison. A broadband seismometer that may become part of the NERC British Geological Survey's UK network has been installed in the basement to help with investigations into noise, including that from earthquakes, within the gravity data sets.

LIDAR

We are regularly collecting simultaneous LIDAR and SLR data when tracking LAGEOS and are developing techniques to measure the optical density and evolution of aircraft contrails (Figure 13-38), a major atmospheric pollutant in the SE of the UK.

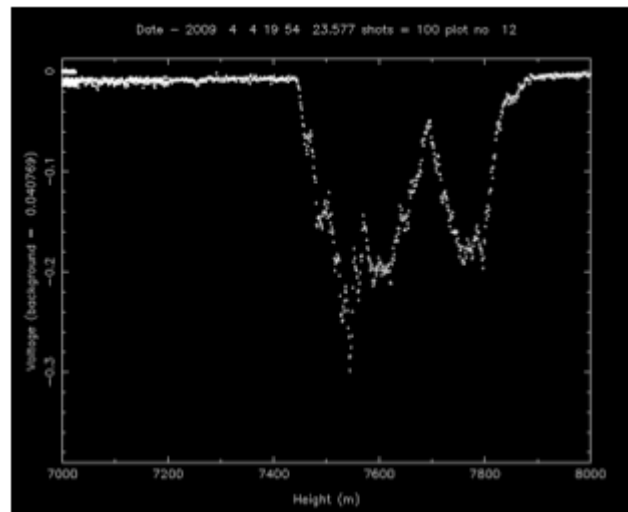

Figure 13-38. The plot shows a scan of a contrail at a height of 7.5 km above the Facility.

References

- Shoobridge, T., Benham, D. 2008: One-way System Calibration Techniques. To appear, Proc 16th LR Workshop, Poznan, Poland and online at: http://cddis.gsfc.nasa.gov/lw16/docs/presentations/adv_3_Shoobridge.pdf.
- Wilkinson, M. 2008: High speed pockels cell shutter and the Herstmonceux MCP-PMT detector. To appear, Proc 16th LR Workshop, Poznan, Poland and online at: http://cddis.gsfc.nasa.gov/lw16/docs/presentations/rep_6_Wilkinson.pdf.

Contacts

Dr. Graham Appleby
Philip Gibbs
NERC Space Geodesy Facility
Herstmonceux Castle
Hailsham
East Sussex BN27 1RN
UNITED KINGDOM

E-mail: gapp@nerc.ac.uk
E-mail: pgib@nerc.ac.uk
Voice: +44 (0)1323 833888
Fax: 44 (0)1323 833929
Web: <http://nercslr.nmt.ac.uk>

Kiev, Ukraine

Mikhail Medvedsky, Viktor Pap/Agency Main Astronomical Observatory of NAS of Ukraine

Introduction

The Main Astronomical Observatory of Ukraine built the Kiev SLR station in 1985. Since April 1996, the station has performed routine satellite laser ranging operations and on January 22, 1999, the station began permanent laser tracking operations as part of the ILRS network. Today, most low-orbiting satellites as well as LAGEOS are tracked on routine basis. High-orbiting satellites, such as GPS, Etalon and GIOVE, are not tracked due to the lack of required technical resources. Four people work at the Kiev station; the system is operational 6 to 7 days per week, weather permitting. The station performs ranging activities at night in semiautomatic mode with only one operator.



Figure 13-39. Kiev telescope and station staff (left to right): Vitaliy Kostogryz, Michael Medvedsky, and Viktor Pap; the staff also includes chief engineer Juriy Glushchenko.

System Upgrades

In March 2008 a new laser was installed with the following specifications: 65 ps pulse duration, up to 15 Hz repetition rate, and up to 35 mJ energy in 532 nm. Using this laser, we can range with better precision, but we use an older, Soviet manufactured PMT FEU-74 receiver. Metrological data are collected from the observatory's automated met station. Since September 2008, the station uses a rubidium frequency standard. The CFD discriminator has been adjusted and the single-shot RMS has improved to 2 cm (see Figure 13-40).

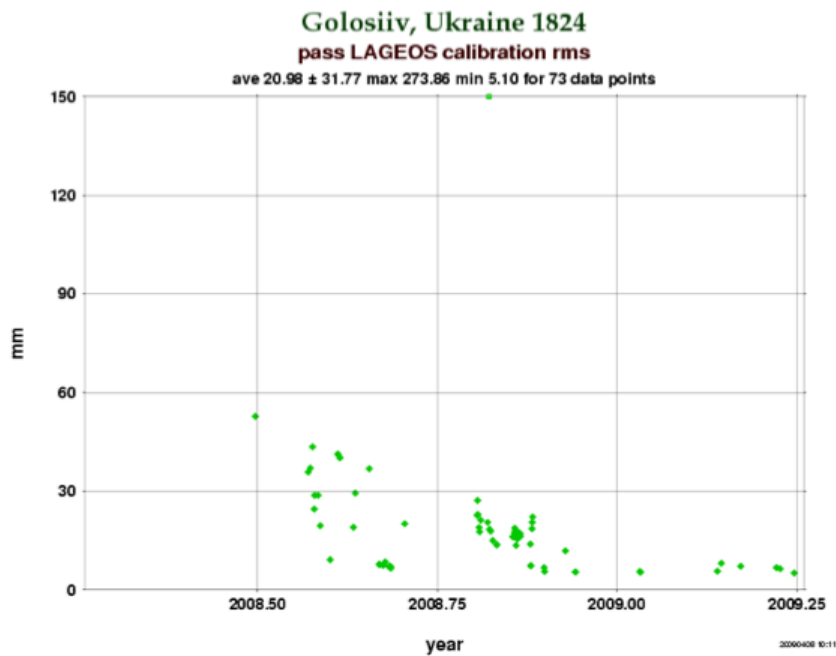

Figure 13-40. Calibration RMS

Statistics

From March through December 2008, Kiev observed 725 passes from low-orbiting satellites and 90 passes from LAGEOS-1 and -2. During 2009 (January through 13 April), the station tracked 169 low satellite passes and 27 LAGEOS passes.

Future Plans

In the near future, the staff plans to develop a daylight ranging unit and plans to obtain a new time interval counter and PMT.

Contact

Dr. Mikhailo Medvedskij
Main Astronomical Observatory of
NAS of Ukraine
Golosiiv, 03680 Kyiv-127
UKRAINE

E-mail: medved@mao.kiev.ua
Phone: +380-44-5264759

Kunming, China

Xiong Yaoheng, Zheng Xiangming, Fu Honglin, Li Yuqiang/National Astronomical Observatories, Yunnan Observatory, CAS

Current Operations

The Kunming station performed a system upgrade from mid-2003 through 2006. The new system is shown in Figures 13-41 through -44.



Figure 13-41. New Kunming SLR system facility.



Figure 13-42. Kunming telescope.



Figure 13-43. Drive and servo-control system.



Figure 13-44. Two new optical benches.

The station resumed operations in 2007 with improved tracking capabilities. Since the system's range bias was large, we have conducted a careful check of meteorological parameters, time signal, system calibration, etc.

Near Future Plans

A proposal for upgrading the performance of the entire Chinese SLR network has received preliminary approval under the Monitoring Network for Structure Environment of China Mainland and was started in 2007. The main upgrades for most of the SLR stations in the network include kHz laser ranging and daylight tracking capabilities.



Figure 13-45. The Kunming SLR station staff (left to right): Fu HongLin (engineer), Dr. Li YuQiang, Dr. Li ZhuLian, He Chao, He LiJuan, Professor Xiong YaoHeng, Zheng XiangMing (senior engineer), He ShaoHui (engineer).

Contact

Zheng XiangMing

E-mail: zhengxm@mail.ynao.ac.cn

Phone: 86-871-3920403-801

Li YuQiang

E-mail: lyq@mail.ynao.ac.cn

Voice: 86-871-3920403-805

Yunnan Observatory

Fax: 86-871-3920599

National Astronomical Observatories

Voice: 86-871-3920823

Chinese Academy of Sciences

P. O. Box 110

Kunming 650011 Yunnan

CHINA

Lviv, Ukraine

Sofiya Apunevych, Andriy Bilinsky, Yaroslav Blagodyr, Natalia Virun, Eva Vovchyk, Konstantyn Martyniuk-Lototsky/Astronomical Observatory of Ivan Franko National University of Lviv

Recent Developments

During 2007-2008 the Lviv station tracked 283 LEO satellite passes (with a total of 4,158 normal points) and 24 LAGEOS passes (218 normal points).

From June through August 2007, the TPL-1M telescope mirrors were replaced (Figure 13-46).



Figure 13-46. Replacement of Lviv telescope mirrors.

After tuning the optical channels of the telescope (Figure 13-47), a map of mechanical inaccuracies was built based on observations of stars from the FK5 catalogue. This mapping provided a capability to guide the telescope with an accuracy of 20 angular seconds without angular encoders. Test observations were carried out for satellites passing through the shadow of the Earth without visual control through the guide.



Figure 13-47. Telescope after refurbishment.

A software package has been developed and implemented on the Linux platform that includes a driver for telescope control, a user interface based on nCurses and GPM libraries, utilities for building maps and for automated handing of meteorological data, and scripts for e-mail and data archiving.

The SLR station “Lviv-1831” was included in the State Registry of National Patrimony of Ukraine by the decree of the Cabinet of Ministers of Ukraine N 1345-p dated October 22, 2008.



Figure 13-48. Lviv station personnel (back row, left to right: Andriy Bilinsky, Yaroslav Blagodyr, Konstantyn Martyniuk-Lototsky; front row, left to right: Sofiya Apunevych, Eva Vovchuk, Natalia Virun).

References

Blagodyr Ya., Bilinsky A., Martynyuk-Lototsky K., Lohvynenko O., Virun N. Overview and performance of the Ukrainian SLR station “Lviv-1831”, *Artificial Satellites* 2007, Vol. 42, N1, pp. 9-15.

http://ilrs.gsfc.nasa.gov/stations/sitelist/LVIL_sitelog.html

http://www.mao.kiev.ua/EOP/ENGLISH/slr/lviv/slr_lviv_location.htm

<http://astro.franko.lviv.ua>

Contact

Yaroslav Blagodyr

E-mail: blagod@astro.franko.lviv.ua

slr1831@ukr.net

Voice: +380 32 2600393

Astronomical Observatory of
Ivan Franko National University of Lviv
St. Kyrylo i Mefodij, 8,
79005, Lviv
UKRAINE

Matera, Italy

Giuseppe Bianco/Agenzia Spaziale Italiana, Centro di Geodesia Spaziale “Giuseppe Colombo“, Matera, Italy

During 2007-2008 the MLRO (Matera Laser Ranging Observatory) has, for the most part, been in a routine operations phase. The photograph below (Figure 13-49) shows the current MLRO engineering and operations crew.



Figure 13-49. The MLRO engineering and operations crew. Standing (left to right): G. Bianco, R. Sala, C. Luceri, M. Paradiso, M. Guidobaldi, G. Nettis, D. Iacovone, G. Corvino. Seated: F. Schiavone, G. Colucci, M. Nicoletti, G. Nicoletti, E. Lunalbi

During this period, the development of an annoying range bias of unknown origin triggered a strong need to better track the system behavior with appropriate and independent quality checks. For this reason we have developed and put into operation a system which monitors a number of “health indicators” and prompts for action if one or more of such parameters exceed their respective “safe” boundaries. This work has been documented in several presentations at recent ILRS workshops.

Also during 2007-2008, the original laser seeder was replaced with a new model made by High-Q Austria. Moreover, in 2008 a non-trivial problem occurred to the elevation axis. Both events have caused quite long interruptions in the station’s normal operational activity. Full-time (24/7) operations resumed in the summer of 2008.

Table 13-2 (following page) reports, for each satellite, the number of passes tracked by MLRO as well as the number of normal points produced in years 2007 and 2008.

Table 13-2. MLRO 2007-2008 Data Production

Satellite	2007		2008	
	#passes	#NPts	#passes	#NPts
Beacon-C	298	4,911	354	6,226
Stella	169	1,279	203	1,463
ANDERR-Passive	1	10		
Jason-2			79	994
Starlette	447	4,014	500	4,617
Ajisai	516	7,339	631	8,719
Oicets			2	24
Jason-1	289	6,420	277	5,322
Larets	103	602	119	612
ERS-2	168	2,583	244	3,143
Envisat	181	2,628	224	2,691
TerraSAR-X	26	468	85	1,309
CHAMP	11	115	14	109
GRACE-A	24	439	29	427
GRACE-B	47	820	28	444
GFO-1	160	2,044	150	1,835
LAGEOS-1	548	4,903	572	4,756
LAGEOS-2	431	3,775	449	4,203
Etalon-1	74	405	37	195
Etalon-2	77	410	20	112
GLONASS-89	2	6		
GLONASS-95	54	265	8	40
GLONASS-99	110	576	35	169
GLONASS-102	16	66	13	44
GLONASS-109			7	39
GIOVE-A	68	342		
GIOVE-B			4	19
GPS-35	15	69	1	6
GPS-36	9	46	2	5
Totals:	3,844	44,535	4,281	47,523

Contacts

Dr. Giuseppe Bianco
Agenzia Spaziale Italiana (ASI)
Centro di Geodesia Spaziale
C.da Terlecchia, 75100 Matera
ITALY

Voice: +39-0835-377209
Fax: +39-0835-339005
E-mail: giuseppe.bianco@asi.it

Dr. Vincenza Luceri
e-GEOS S.p.A.
Centro di Geodesia Spaziale
C.da Terlecchia, 75100 Matera
ITALY

Voice: +39-0835-377231
Fax: +39-06-40999961
E-mail: cinzia.luceri@telespazio.com

McDonald TX, USA

Peter J. Shelus, Jerry R. Wiant, Randall L. Ricklefs, John C. Ries, Judit G. Ries/Center for Space Research and McDonald Observatory, University of Texas at Austin

MLRS Activities

The McDonald Laser Ranging Station (MLRS) is located at McDonald Observatory in the Davis Mountains of west Texas, near the town of Fort Davis, TX (USA). In addition to ranging to artificial satellites (SLR), it is one of the very few stations that also performs laser ranging to the Moon (LLR).



Figure 13-50. MLRS.

SLR support comes from a NASA operations contract; LLR support comes through a grant from the National Science Foundation. NASA support for LLR was discontinued several years ago. LLR data from MLRS has been the only lunar data deposited into the ILRS data archives during this reporting period. The MLRS staff (Figure 13-51) consists of: Dr. Peter J. Shelus (Project Manager), Mr. Randall L. Ricklefs (Software Manager), Mr. Jerry R. Wiant (Project Engineer), Mr. Ken T. Harned (observer), Mr. Anthony R. Garcia (observer), and Ms. Rachel M. Green (part-time Technical Assistant).

SLR

SLR data volume from the MLRS continues to be less than optimal, due to the reduction in manpower that was forced by a sequence of funding cuts.

In addition, the station is showing its age. The MLRS is in need of a serious upgrade and refurbishment. Day-to-day activity is directed toward keeping the station operational and in a data-gathering mode. On the positive side, the MLRS has been one of the earliest adopters of the new ILRS prediction and data formats (CPF and CRD).



Figure 13-51. Members of the MLRS staff (Rachel Green, upper left, Jerry Wiant, upper right, Anthony Garcia, lower right, and Ken Harned, lower left).

ICESat

Ranging to the ICESat target continues. The MLRS is one of only a handful of ILRS SLR stations that have been configured to range safely to ICESat. This satellite has a downward looking telescope that can be irreparably damaged by inadvertent laser pulses from the ground.

LLR

Ranging to the Moon continues. The MLRS is one of only two ILRS laser stations that have been ranging to the Moon during this reporting period. The LLR station at Apache Point, New Mexico, although just starting to range to the Moon, is still not an official member of the ILRS, and its data are not in the ILRS data archives. The French LLR station has been down for more than three years for refurbishment and upgrade.

A Hamamatsu MCP has been made available by GSFC to the MLRS to replace the two Varian photomultiplier tubes that had been used over the past 25 years for LLR operations. Although not as sensitive as the Varian tubes and a bit noisier, it has allowed the continuation of LLR observations.

MLRS LLR data are available through the ILRS data centers. The data are transmitted to the centers in near real-time, using standard ILRS formats.

LRO-LR

The MLRS has been designated as a ground station to participate in the LRO Laser Ranging (LRO-LR) project. Extensive work has been performed to get the station ready for that project. LRO was launched in June 2009.

Data Quality Control

John Ries and Richard Eanes perform regular SLR data processing and quality control at the Center for Space Research (CSR) located at the University of Texas at Austin. The analogous LLR tasks are performed by Judit Ries.

Contact

Dr. Peter Shelus (Austin)
University of Texas, Center for Space Research
3925 West Braker Lane, Suite 200
Austin, TX 78759-5321
USA

Voice: 512-471-7599
Fax: 512-471-3570
E-mail: pjs@csr.utexas.edu

Mr. Jerry R. Wiant (MLRS)
9 Lunar Cir
McDonald Obs., TX 78734
USA

Voice: 1-432 426 3668
E-mail: jrw@astro.as.utexas.edu

Metsähovi, Finland

K. Arsov, A. Raja-Halli, J. Näränen, M. Poutanen/Finnish Geodetic Institute, Finland

The Metsähovi research station was founded in the mid-1970s, and over the years it has become an essential part of the activities of the Finnish Geodetic Institute. The instrumentation of the station serves both the Institute's own research and the international scientific community. The following instruments are currently installed at the Metsähovi research station: satellite laser ranging (SLR), geodetic Very Long Baseline Interferometry (VLBI) in a co-operation with the Helsinki University of Technology, GPS and GLONASS receivers, a DORIS beacon, and a superconducting gravimeter. Absolute gravity is regularly measured in the gravimetric laboratory where the national reference point of gravity exists. There is also a seismometer from the University of Helsinki. Metsähovi is one of the few fundamental stations in the world where all major geodetic observing instruments are installed in the same site.

The satellite laser ranging system operating through the middle of 2005 was acquired in 1994. It consists of a 1-meter telescope, made by the University of Latvia in Riga, and a mode-locked Nd:YAG laser with less than 50 ps pulse length. Ranging data showed a precision of about ± 20 mm. The system was designed and constructed by the late Dr. Matti Paunonen. Maintenance of the old system became more and more difficult, and in 2005 a decision was made to replace the laser with a more modern one.

Renewal of the laser started in mid-2005 and therefore observations were taken only during the first half of that year. Due to unexpected delays, the renewal has taken much longer to complete than originally anticipated. In 2006 a decision was made to purchase a modern kHz laser and a contract was arranged with the High Q Laser Production GmbH of Austria. The ordered laser is a diode-pumped Nd:VAN solid state laser with the pulse rate up to 2 kHz and the pulse energy > 0.5 mJ. The laser is of the same type that Graz and Herstmonceux are currently using.

The complete renovation of our old SLR system is progressing, including the 1 m telescope; the primary mirror has been re-coated, new motors and encoders have been purchased and are currently in the implementation. An optical/mechanical solution for a separate beam path for the outgoing and incoming beams is in an implementation phase. Unfortunately, due to these changes, the old telescope software is not operable, so complete programming of new telescope controlling software is also ongoing. At the same time, software capable of kHz data tracking is under development. We replaced our old PMT detector with a digital C-SPAD from the Czech Republic; this detector is capable of handling kHz data. For the timing, we purchased a new A032-ET event timer from Riga; software implementation regarding the interaction with A032-ET is ongoing. For gating, we purchased a Range Gate Generator FPGA card from Graz, hosted into an industry computer; this card is also currently being implemented into our new SLR system. The timing and meteo servers are completely renewed with a new GPS timing receiver together with the hydrogen maser signal; a new meteo server is being designed and implemented together with the timing server.

Currently, a software module incorporating and controlling all of the above-mentioned hardware is under development, together with a "smart" session planner as an integral part of our new SLR operational software. The platform chosen is Windows Vista and the programming language is visual C++ with usage of the MFC libraries.

Parallel to the renovation of the 1 m telescope, we are seeking funding for a new telescope and dome to host the 2 kHz system. If successful, we hope to continue to use the 1 m telescope with a slower but a more powerful laser for MEO type satellites, including current and future GNSS.

We do hope that we will start our first 2 kHz observations in 2010 and thus retain our operational status in ILRS.

Contact

Dr. Kirco Arsov
Finnish Geodetic Institute
Department of Geodesy and Geodynamics
P.O. Box 15
Geodeetinrinne 2
02431 Masala
FINLAND

Voice: +358-(0)9-2564995
Fax: +358-(0)9-2955 5200

Monument Peak CA, USA

David Carter/NASA GSFC, Julie Horvath and Scott Wetzel/HTSI



Figure 13-52. MOBLAS-4 in Monument Peak, CA



Figure-13-53. The CNES DORIS antenna co-located at Monument Peak.

MOBLAS-4, located on Monument Peak, on Mt. Laguna, California, provided SLR tracking in its 24th and 25th years in this location during 2007 and 2008. This NASA contractor-operated system underwent significant upgrades and improvements during this time; however, the system experienced a major radar failure during the summer of 2007 that forced the crew to operate using a mount observer, decreasing the system operating hours to only a single shift, five days per week. The station's productivity was further hampered by the departure of a MOBLAS-4 crew member in 2008. Due to an on-going shortage of HTSI engineers and higher priority NASA projects and system repairs, this radar failure has yet to be corrected.

During 2007, CNES requested a modification to the DORIS antenna (Figure 13-53) located at Monument Peak due to the enforcement of more stringent installation requirements for the DORIS antennas. These included an increased minimum curvature radius for the cables, reduced mechanical constraints on the antenna connectors, a ban on the use of bent connectors used in concrete pillar-equipped sites, and a clear sky view above 5° (vs. 10° which was the former objective). HTSI supported the reconstruction by the IGN team, and all modifications were completed by the end of the year.

During 2008, Ron Sebeny (Figure 13-54) took responsibility of the MOBLAS-4 station as the acting station manager. Mr. Sebeny and the HTSI team coordinated several improvements to the system that enhanced tracking capability as well as streamlined station operations. The first station upgrade was a long overdue overhaul of the NASA SLR real-time computer subsystem. The on-site real-time controller computer had last been replaced in the early 1990's, and the software, as well as the new ILRS data format requirements, were tasking it beyond its capability. The PCI bus controller with an upgraded real-time operating system, and new CAMAC controller, serial card, and timing card, replaced the older ISA technology. The replacement subsystem greatly improved real-time operations, system stability and speed, and added much needed data storage capacity.



Figure 13-54. Ron Sebney.



Figure 13-55. Theodore Doroski.

The most significant improvement to the station was the installation of the new MOBLAS laser upgrade that was proven at MOBLAS-7 earlier in the year. HTSI hardware engineers Tom Oldham and Dennis McCollums, traveled to MOBLAS-4 in August 2008 to replace the flowing dye cell with a Crystal Saturable Absorber. This new configuration completely eliminated the need for hazardous chemicals and laser dye, and shortened laser maintenance and start-up time. During the installation, the laser table was completely stripped and rebuilt. The system optics were inspected, cleaned, replaced, and aligned. The system was brought back to operations by the end of the month, and the station tracking efficiency was markedly better. The station crew, consisting of Mr. Sebney and Theodore Doroski (Figure 13-55), has increased tracking on all satellites including all GNSS satellites, as well as the very difficult low Earth orbiters. MOBLAS-4 continues to be a core ILRS station with over 85,500 high quality normal points for these years.

Contact

David Carter
NASA GSFC
Code 453
Greenbelt, MD 20771
USA

Voice: 301-614-5966
Fax: 301-286-0328
E-mail: David.L.Carter@nasa.gov

Mount Stromlo, Australia

Chris Moore/EOS Space Systems Pty Ltd, Gary Johnston/Geoscience Australia

The Mt. Stromlo Space Research Centre is a fundamental space geodesy site that currently consists of a high precision satellite laser ranging (SLR) station based on a 1m aperture telescope, and an experimental facility based on a 1.8m aperture telescope. The site also supports IGS GPS and GLONASS receivers, an IDS DORIS beacon, and a comprehensive local tie network.

Mt. Stromlo SLR Station (STL3, 7825)

The Mt. Stromlo SLR station has now been operating continuously since December 2004 and continues to be one of the most productive SLR stations in the ILRS network. Figure 13-56 shows the productivity that has been obtained over the 2006 to 2008 time period in terms of passes tracked of low Earth orbit (LEO), high Earth orbit (HEO), and LAGEOS satellites.

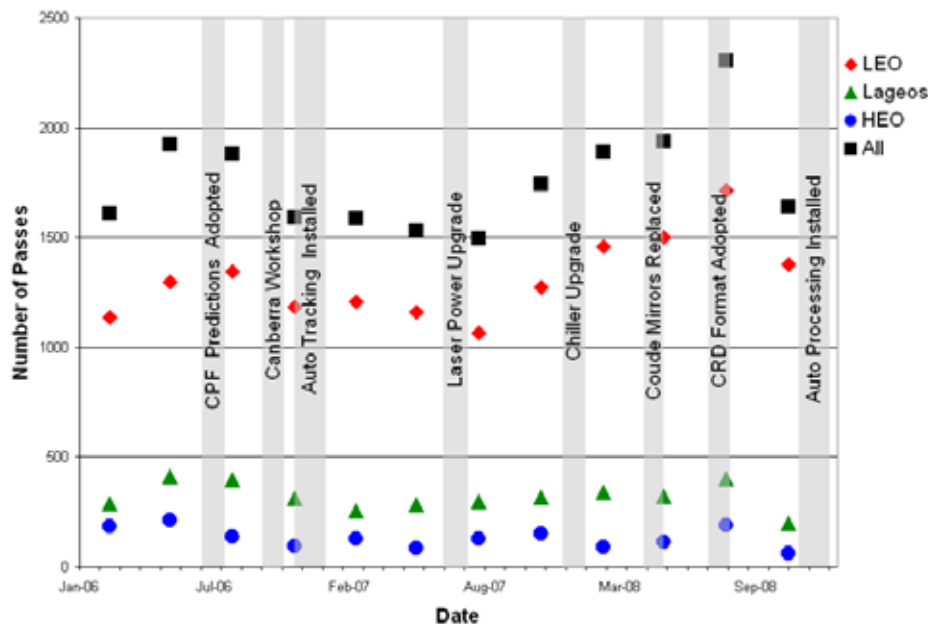

Figure 13-56: Productivity at Mt Stromlo during 2006-2008 with major events identified.

This figure also shows some of the major events that occurred at the station during this period. A major milestone was an upgrade to the laser power in mid 2007 to allow routine ranging through the telescope enclosure window. Since this upgrade, the station has operated at a 60 Hz ranging rate, with a power of over 1.2 W, and the station has been able to return to full auto-tracking operations with minimal operating staff.

The station's software systems have undergone significant development during 2006-2008, with upgraded infrastructure systems and applications supporting:

- Adoption of new CPF prediction formats, Q2 2006
- Auto-tracking by Q2 2007,
- New CRD format reporting using XML output files, Q3 2008
- New manual post processing, in Q4 2008
- Automated post-processing in Q1 2009.



Figure 13-57. EOS Space Systems Staff located at the Mt Stromlo SRC.
Dr Chris Moore (left) and Peter Wilson (right).

Mt. Stromlo Experimental Ranging Station (STRK, 7826)

The experimental system introduced in the last report continues to provide research and development facilities for visually tracking and ranging to space debris, the development of guide star and ablation lasers, and other projects (see <http://www.eos-aus.com> for more information). Due to these other projects, the facility has not been able to be used for lunar laser ranging activities.

GNSS

Both GNSS sites at Mt. Stromlo (STR1 and STR2) continue to provide a variety of data products to the IGS including real time 1 Hz data for a pilot project. Both sites are equipped with dual GPS and GLONASS receivers. They provide GLONASS data to the IGLOS pilot project under IGS. A third pillar (STR3) has been constructed and is awaiting receiver installation.

Local Tie Survey

A full local tie survey was completed in 2006 including the connection to the 1.8m telescope and the new GPS mount, as described in Woods (2007).

Gravimetry

The Japanese/ANU superconducting gravimeter continues to operate in a basement at the Australian National University's (ANU) Mt. Stromlo Observatory. GA and ANU, as part of the AuScope, have acquired our own FG5 and several measurements have taken place since April 2008 at new absolute gravity marks in a room next to the superconducting gravimeter. Our first occupation at the Yarragadee SLR station's gravity hut was completed in December 2008 as part of a new observation campaign. GA and ANU (as part of AuScope) are conducting a feasibility study of creating a small absolute gravity comparison facility (6-8 AG gravimeters) at the Mt. Stromlo Observatory.

References

Woods, A.R., (2007): "The 2006 Mount Stromlo Local Tie Survey", Geoscience Australia Record 2007/18, 27pp.

Contacts

Dr. Christopher Moore
EOS Space Systems Pty Ltd
111 Canberra Avenue
Griffith, ACT 2603
AUSTRALIA

Voice: +61 2 6287-2953
Fax: +61 2 6287-2951
E-mail: cmoore@eos-aus.com

Mr. Gary Johnston
Geoscience Australia
PO Box 378 Canberra ACT 2601
AUSTRALIA

Voice: +61 62499049
Fax: +61 62499929
E-mail gary.johnston@ga.gov.au

Potsdam, Germany

Ludwig Grunwaldt/GFZ Potsdam



Figure 13-58: SLR System 7841 in winter 2008



Figure 13-59: LRR array during vibration testing

The Potsdam SLR system (7841) was maintained in standard operational conditions (with day and nighttime tracking capabilities for the LEO and LAGEOS satellites) during 2007 and 2008 and tracked a total of 2,024 and 2,158 passes, respectively. The number of achievable passes is mainly limited by the sky conditions in our mid-northern latitude. No substantial changes in hardware and software were performed during the 2007-2008 period. In October 2008, the narrowband filter in the receiving path had to be exchanged and the laser transmitter underwent intensive re-alignment. Tracking of high-orbiting satellites under nighttime conditions, which was suspended in 2006/2007, could be resumed afterwards.

Several system upgrades are planned to start in 2009, which will finally result in kHz tracking capability with improved data quality. New detectors are envisaged for the receiving subsystem (both a SPAD and a hybrid photodetector) in order to increase the data yield, especially for higher satellites.

Low-signature laser retroreflector arrays were manufactured, tested and delivered for the X-band radar missions TanDEM-X and KOMPSAT-5, which are due for launch in 2009 and 2010, respectively. Three more samples of this 4-prism reflector of the CHAMP/GRACE type are under contract for the ESA magnetometry mission Swarm and another one for the Spanish radar satellite PAZ. The array on TerraSAR-X (constructed by GFZ) supports the external calibration/validation of the highly precise GPS-derived orbits for this mission via the excellent SLR data coverage obtained by the ILRS community.

Contact

Dr. Ludwig Grunwaldt
GeoForschungsZentrum Potsdam
Telegrafenberg
D-14473 Potsdam
GERMANY

Voice: +49-331-2881733
Voice: +49-331-2881164 (SLR station)
Fax: +49-331-2881732
E-mail: grun@gfz-potsdam.de

Riga, Latvia

Kazimirs Lapushka, Kalvis Salminsh/Astronomical Institute of University of Latvia

Main Activities

During 2007-2008, bad weather affected laser ranging activities at Riga (1884). In 2007, there were only 89 clear weather opportunities allowing the station to successfully range to fourteen satellites yielding a total of 670 passes with 538,393 full-rate data points (12,278 normal points). In addition to the bad weather conditions, the surface of the telescope's main mirror was very degraded, after more than twenty years of use. Through funding support from the European Union, we sent the main mirror to the 4H Jena Engineering GmbH factory in Germany for reflecting surface recoating at the end of 2007; the mirror was returned to Riga at the beginning of 2008 (Figures 13-60 and -61).



Figure 13-60. Recoated mirror before installation.



Figure 13-61. Recoated mirror.

In 2008, the weather conditions were worse than in previous years, and the system's first possible ranging attempts occurred at the end of April. There were only 56 clear periods in all, allowing ranging to sixteen satellites yielding 382 passes and 571,551 full-rate points (8,080 normal points).

According to the satellite range bias analysis reports from Dr. Toshimichi Otsubo, the calculated average per year range bias (ARB) for satellites LAGEOS-1 and -2 are show in Table 13-3.

Table 13-3. Riga Average Range Bias for LAGEOS-1 and -2

2007	LAGEOS-1	77 passes	ARB = -9.5 mm
	LAGEOS-2	38 passes	ARB = -2.3 mm
2008	LAGEOS-1	49 passes	ARB = -8.9 mm
	LAGEOS-2	14 passes	ARB = 10 mm

During 2007-2008, an intensive design and construction effort was undertaken to realize separation of the telescope transmitting and receiving channels in accordance with drawings, as reported in the 2003-2004 edition of the ILRS report. The system was constructed and tested in many aspects, however we were not satisfied with the results. The transmitter channel operated well, but the receiver channel did not, causing difficulties for high satellite ranging. We are not presently using this new configuration for actual satellite ranging and will perform another attempt with the new configuration during 2009.. It is important for us to solve this problem in order to increase the amount of data from low and very low orbiting satellites.

A major research task for the staff is to increase the system calibration stability together with stabilization and minimization of a range bias error for different satellites.

A Vaisala WXT-510 weather transmitter station was installed in 2007 and since November 11, 2007, meteorological data are recorded at the site every 10 minutes.

Significant software efforts were made to accommodate the new ILRS data and prediction formats together with the development of new data processing and prediction software.

Contact

Dr. Kazimirs Lapushka
Astronomical Institute of University of Latvia
Blw. Rainis 19
Riga, LV-1586
LATVIA

Voice: 371 7 611984
Fax: 371 7 820180
E-mail: riglas@lanet.lv

Riyadh, Saudi Arabia

Dr. Sami Al Humadi, Dr. Attieh Al Ghamdi, Engr. Kahlid Alghamdi, Abdulaziz Bin Sheween.



Figure 13-62. SALRO tracking station circa 2005.

Several factors have affected the number of observations from Saudi Arabian Laser Ranging Observatory (SALRO) shown in Figure 13-62:

- System improvements
- Operators
- Transition
- Weather
- System maintenance

The major hindrance to SALRO data acquisition has been weather and system maintenance. The weather during the past two years, especially during the summer months, has been very dusty and cloudy. Good sky conditions are available at approximately 60 degrees elevation and with 10 kilometers of clean horizon. Because of this environment, we are experiencing difficulty with daylight tracking.

This year, SALRO staff performed an air-conditioning system upgrade and radar installation to replace the mount observer position (Figure 13-63). A new monument with a terrestrial target was built for resurvey purposes (Figure 13-64).



Figure 13-63. SALRO today with aircraft radar and air-conditioning system upgrade.



Figure 13-64. Terrestrial target.

New operators have been trained to support a planned 24-hour, 7 day/week, tracking schedule. The staff of the SALRO station is shown in Figure 13-65.



Figure 13-65. SALRO crew (from left to right): Ibrahim Al Mubarak, Sultan Almasuod, Muhamad Al Sultan and Engr. Roy Rama. Not shown: Engr. Kahlid Alghamdi, Abdulaziz Bin Sheewien, Naif Al Aseery, Saud Al Harkan, Alex Torecampo.

Contact:

Dr. Attieh Alghamdi
Photonics Department room 203
Bldg. 17, 2nd floor
P.O. Box. 6086
Riyadh 11442
KINGDOM OF SAUDI ARABIA

E-mail: alghamdi@kacst.edu.sa
Voice: +966 1 4813325
Fax: +966 1 4814572

San Fernando, Spain

Jorge Gárate, José Martín Dávila, Manuel Quijan/Real Instituto y Observatorio Armada

In memory of Carmelo Belza.

Since January 1, 2007 until the end of 2008, the Spanish San Fernando Naval Observatory, Satellite Laser Ranging station (SFEL, 7824), delivered about 90,000 normal points to the International Laser Ranging Service data centers, corresponding to more than 6,500 successful satellite passes. Data quality remains stable in respect to the previous year: 14 millimeters for single shot rms and 3 millimeters for the normal points rms over LAGEOS passes, in accordance with the SLR Global Performance Report Cards.

But the most remarkable event is the fact that this station has already been able to track high-orbiting satellites; we have obtained more than 120 passes on HEO targets. This successful tracking was a consequence of developing the Spanish Government funded research action entitled “Seguimiento láser sobre satélites GNSS (GPS, Galileo, etc)” (Satellite Laser Ranging on GNSS satellites as GPS, Galileo, etc, Ref: ESP2004-04598). This action was scheduled for the period 2005-2007, but it was eventually extended to the end of 2008. Besides the optical reviewing made in 2006 (and already reported) additional work was performed to improve the pointing accuracy. A new telescope mount weight distribution configuration was made, trying to get a more uniform system response to the pointing orders. Furthermore, some additional work was made to reduce noise affecting the system, interfering with pointing procedures, and producing tracking interruptions. The high noise level has not allowed us to implement the event timer yet. We consider this implementation a key contributor to our participation in the time transfer experiments such as T2L2.

Future developments will focus on reducing the noise level as well as improving the system’s pointing accuracy. We are planning to change the pointing system by first replacing and testing the orientation system. If successful, the elevation system will also be replaced.

The most painful news for us during this period was the loss of our technician engineer Carmelo Belza. He passed away in September 2008 due to a rare disease. We miss his immense contribution to our station developments!



Figure 13-66. Left to right: Manolo Quijano (San Fernando SLR station engineer) and Carmelo Belza; Emilio Lopez (retired San Fernando SLR station operator) and Carmelo.

Contact

Jorge Garate
Real Instituto y Observatorio Armada
Sec. Geofisica, C. Cecilio Pujazon S/N
11110 San Fernando, Cadiz
SPAIN

Voice: 34-956-599285
Fax: 34-956-599366
E-mail: jgarate@roa.es

San Juan, Argentina

E. Alonso, E. Actis, R. Podesta, A. Pacheco/National University of San Juan, Weidong Liu, Yanben Han/National Astronomical Observatories, CAS (NAOC)

Introduction

The SLR station in San Juan Argentina (working under cooperation in astronomy between the National Astronomical Observatories of Chinese Academy of Sciences, NAOC, and the National University of San Juan of Argentina, NUSJA) has operated almost three years, since the end of February 2006. Under the support of the ministries of science and technology of the two countries, China and Argentina (MSTC and MSTA), the Chinese Academy of Sciences, NAOC, and NUSJA, the observations of the SLR station have made excellent contributions to the ILRS. These results are mainly due to the efforts of the station staff from NAOC and NUSJA. The maintenance of the station equipment and dedicated observation is an important contributor to the station's excellent performance. Furthermore, San Juan has excellent weather, having the very dry characteristics of a desert climate with approximately 300 nights per year (a total of 303 mostly clear or partly cloudy nights in 2007, and 331 nights in 2008) where ranging is possible. The altitude is the most important contributor to the stability of the weather conditions. The area's climate is warm, the rains are scarce and irregular and occur mostly in the summer; summaries of the average monthly weather conditions in San Juan are shown in Figures 13-67 and -68. These conditions are very important to successful daylight satellite tracking operations.

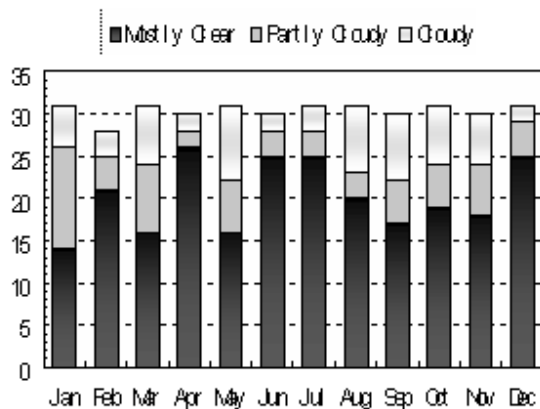

Figure 13-67. Summary of nighttime weather conditions at San Juan in 2007.

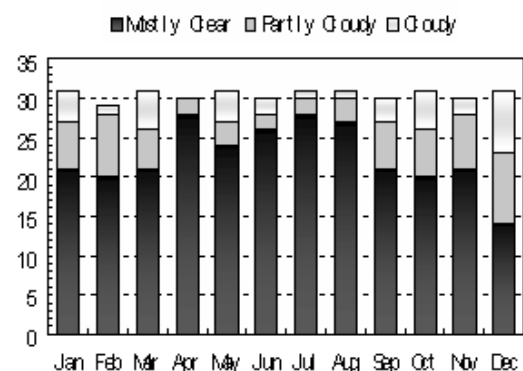

Figure 13-68. Summary of daytime weather conditions at San Juan in 2007.

Operations

The San Juan station acquired 7,087 passes and 98,688 normal points on all satellites during 2007 due to the excellent work of the staff from NAOC, NUSJA, and CASM. In 2008, the station tracked 8,518 passes and 118,159 normal points with the support from personnel from the NAOC, NUSJA, and the Changchun SLR station. The station has added the GIOVE-A and -B satellites (in order to collaborate on the development of the new Galileo system developed by the European Space Agency, ESA), the Chinese satellite Compass-M1, and the Japanese SOHLA-1 into the station's roster of observed satellites. Observational results from San Juan are shown in Figures 13-69, -70a, and -70b. The results clearly show that San Juan SLR station has become one of the fundamental and important stations of ILRS.

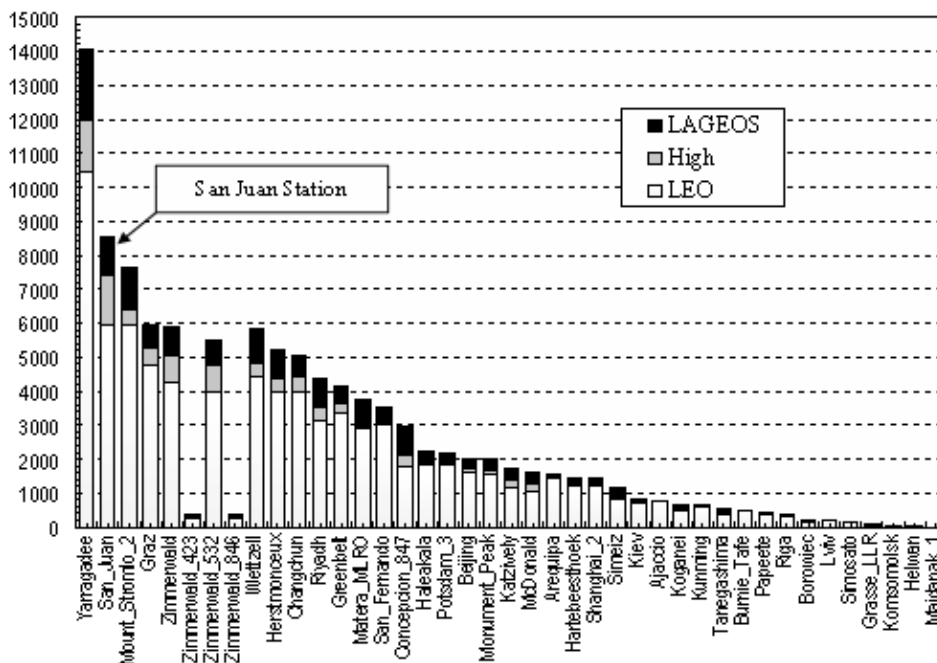

Figure 13-69. Total passes from San Juan (20080101-20081231)

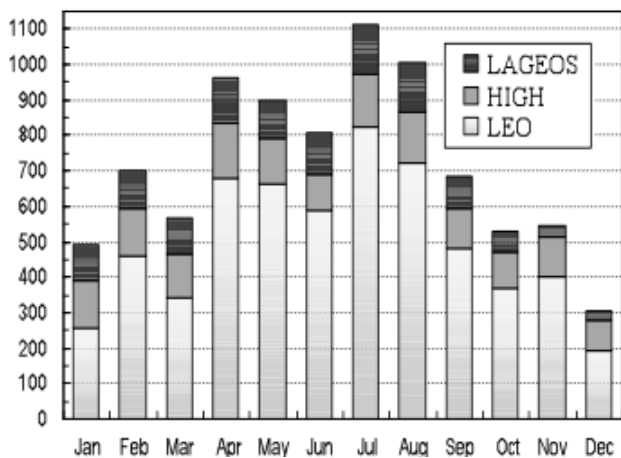

Figure 13-70a. Number of passes per month in 2007.

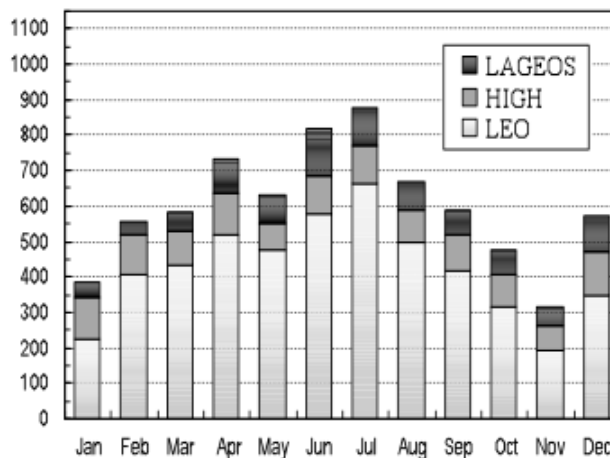

Figure 13-70b. Number of passes per month in 2008.

Future Plans

The NAOC and NUSJA will continue cooperation in the operation and upgrade of the San Juan SLR system. Planned upgrades include installation of a new laser system that includes a semiconductor pumped laser with kHz pulse capability and daytime ranging capabilities. The Ministry of Science and Technology of China will provide the main financial support for the upgrade; the Ministry of Science and Technology of Argentina will provide additional funding. The upgrade will begin in the second half of 2009. In addition, a GPS receiver will be installed near the SLR system.

The ministries of science and technology of the two countries, the Chinese Academy of Sciences, and the National University of San Juan have confirmed that they will continue to provide the necessary support to SLR in order to obtain a higher productivity and quality of results for the ILRS and the research field in general.

Contacts

Prof. E. Alonso, Prof. E. Actis
Observatorio Astronómico Félix Aguilar
Benavídez 8175 – Oeste
5407 – Marquesado
San Juan
ARGENTINA

E-mail: esteralons@hotmail.com
E-mail: actis2003@yahoo.com.ar
Voice: +0054-264-4231467
Fax: +0054-264-4238494

Prof. Yanben Han, Weidong Liu
National Astronomical Observatories, CAS
A20 Datun Road
Chaoyang District
100012 Beijing
CHINA

Voice: +0086-10-64888730
E-mail: hyb@bao.ac.cn
wliu@bao.ac.cn

Shanghai, China

Dr. Sami Al Humadi, Dr. Attieh Al Ghamdi, Engr. Kahlid Alghamdi, Abdulaziz Bin Sheween/KACST

During the 2007-2008 time period the Shanghai SLR station concentrated on upgrading the system through the support of the second stage of the national project “Crustal Movement Observation Network of China (CMONOC)”. The following sections detail improvements that have been done at Shanghai since 2007.

Event Timer

Since the beginning of 2007, the A032-ET event timer from the Riga University in Latvia replaced the old counters (HP5370B and SR620) in routine operations.

New Encoders

New encoders from Renishaw (UK) with a resolution of 0.7 arcsec and a diameter of 300mm replaced the very old optical encoders that were made by the Changchun Institute of Optics and Mechanics in 1982. The new encoders have been installed for routine observations since September 2009. The tracking accuracy of the telescope has been greatly upgraded to 1 arcsec.

KHz Ranging Upgrading

The hardware and software for kHz ranging capability have been under development since 2007. The controller and data preprocessing software have been built based on the FPGA, the range gate board with a resolution of 5ns for kHz ranging. Experimental kHz ranging to LAGEOS, Ajisai, BE-C was done in April-May 2008 with a Q-switched laser with a 1 kHz repetition rate.

A new kHz laser bought from Photonics Industries, USA (Figure 13-74) was received in August 2009. The output of the laser is as follows: 3mJ (532nm), 10-20ps, 1 kHz, 0.6mr divergence (beam diameter 2mm). The new laser has been used in routine operations since September 2009. Up to several hundred thousand points per pass can be obtained for LAGEOS, Ajisai, etc. The laser case is airtight and cannot be opened, while the output energy has been reduced since its operation. Therefore, the quality of the new laser still needs to be examined.

Daylight Tracking

The Shanghai station obtained some daylight tracking data from LAGEOS as well as LEO satellites during 1996-2000. Since that time we have not been able to continue daylight tracking due to the poor beam pointing stability of the old laser and the frequent alignments required with the Coudé system.

The new kHz laser has a very good beam pointing stability (about 5 arcsec). Therefore, in October 2009, we resumed daylight tracking with the new laser and have obtained some data from Ajisai and BE-C. We are working on further system upgrades for improved daylight tracking capability.

Other Projects

- Un-cooperative target ranging
- Design and manufacture of the LRAs for all Compass satellites
- Laser Time Transfer (LTT) experiment. We built the LTT payload for the Compass-M1 satellite launched in April 2007 and obtained the time comparison results between the space borne rubidium clock and the ground hydrogen maser at the Changchun SLR station.
- Design, manufacture and installation of a new dedicated Compass SLR station in Beijing. The station has a 1-meter aperture telescope with a powerful laser and has the capability to track Compass GEO satellites.

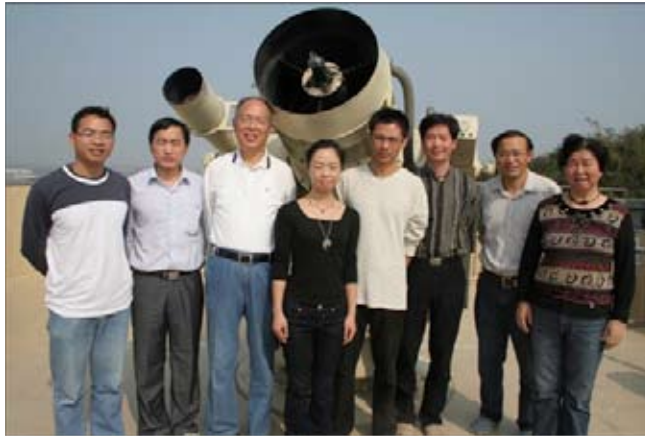

Figure 13-71. Members of the Shanghai SLR station staff (left to right): Wu Zhibo, Zhang Haifeng, Yang Fumin, Meng Wendong, Li Pu, Chen Juping, Zhang Zhongping, ChenWanzhen.



Figure 13-72. The Shanghai SLR telescope.



Figure 13-73. The Shanghai system's EMCCD camera, installed on the telescope.



Figure 13-74. The new Shanghai kHz laser from Photonics Industries, USA.



Figure 13-75. The control room of the Shanghai SLR station. The new pico-event timer (NPET) from Czech Technical University is shown in the middle of the rack; the timer was received in July 2009 and has a timing precision of 0.8ps.

Contact

Yang Fumin
Shanghai Astronomical Observatory
Chinese Academy of Sciences
80 Nandan Road
Shanghai 200030
CHINA

Voice: 86-21-64696290
E-mail: yangfm@shao.ac.cn

Simeiz, Ukraine

A.I. Dmytrotsa/SRI Crimean Astrophysical Observatory

Abstract

The SLR station “Simeiz-1873” was established in 1989. After restoring parts of our old laser transmitter in 2007 we were able to overcome our earlier limit of 1000 passes per year in 2008. This is a very important achievement for our staff; in fact, it is a record for tracking achieved after 19 years of station operations.



Figure 13-76. Simeiz SLR station.

Significant Dates

- Regular satellite laser ranging started at our observatory in 1976 as an INTERKOSMOS station with a laser system installed by K. Hamal on a KRIPTON telescope.
- In 1988, the Crimean Astrophysical Observatory installed a new laser system (near the old station).
- Co-locations with the BKG MLTRS system were conducted in 1991.
- A modernization program was undertaken in 2000 under a Civilian Research and Development Foundation (CRDF) grant.
- A permanent GPS receiver was installed near the SLR station in 2000.
- In 2004, this GPS station, “GPS-CRAO”, became an IGS site.
- In 2008, the SLR station achieved its first year of 1000 passes.

Current Status

As previously stated, the basic problem for our station has been the old laser. This laser, which was constructed on an old laser base, continues to experience problems and requires repair. However, during 2007-2008, we were able to update some components of the laser. These modifications have significantly increased the stability of the laser transmitter. For this reason, we progressed to the level of a 1000-pass per year laser ranging station.

A new master generator with a shorter pulse (150 ps) has been developed, implemented, and successfully tested in an operational satellite ranging mode. We have developed a new optical scheme for the telescope that will considerably improve its optical properties; this modification has not yet been implemented.

Current Goals

Modernization of the Simeiz station is proceeding:

- Repair, restore, or replace the old laser transmitter
- Implement modernization of optical schemes
- Start implementation of the new CRD format into software; plan to complete modifications in 2009
- Continue processing GPS data with GAMIT/GLOBK

Table 13-4. Main elements of the Simeiz station

Element	Description
Mount	Alt-Az. 1m mirror
Angular encoders	Farrand controls, 0.4"
Time interval counter	SR620
PMT	H6533
Time and frequency standard	TC-74, sec from GPS
Laser	350 ps 5Hz. (18 years old)
Software	GUI on a JAVA, server on a C++, low level modules on a C. LINUX
Ephemerides	CPF (in Fortran77)

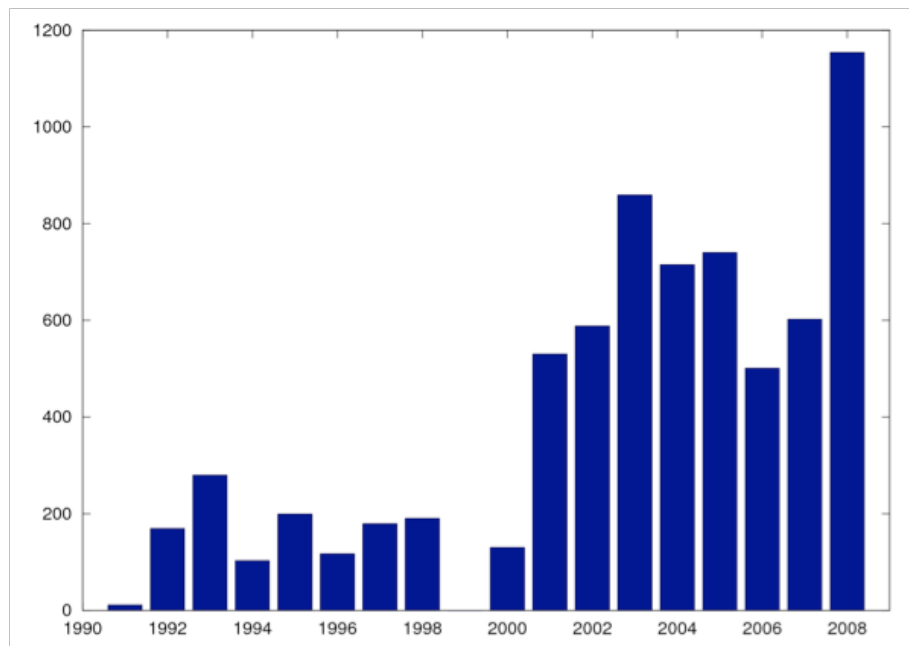

Figure 13-77. Yearly tracking statistics for Simeiz (1991-2008)

Contact

A.I. Dmytrotsa
 SRI Crimean Astrophysical Observatory
 Nauchny, Crimea, 334413
 UKRAINE

Email: dmytrotsa@gmail.com
 Email: simeiz@mail.ylt.crimea.com

Simosato, Japan

Yoshitaka Narita/Hydrographic and Oceanographic Department, Japan Coast Guard

The Simosato Hydrographic Observatory is located in the south of Kii Mountain Range of central Japan. This area was registered as a UNESCO World Heritage site in July 2004 as part of the “Sacred Sites and Pilgrimage Routes”. The site is about four hours by train from Kyoto, a traditional city of Japan. Simosato experiences a large amount of rain, especially in the summer months, due to its location close to the Pacific coast with a mountainous area behind the station.



Figure 13-78. The Simosato station's telescope and staff: (left to right) Keisuke Yamada, Katsushi Ogata, Michihiro Suzuki (Chief), and Yoshitaka Narit.

Simosato's professional staff performs regular maintenance on the SLR tracking system four times a year. Routine operations stopped in June 2007 due to failure of the laser device and the telescope control unit caused by aging deterioration. The components were replaced and operations resumed in April 2008. The pulse frequency, the pulse width, and the output energy of the new laser are 5 pps, 20 ps, and 60 mJ at 532 nm, respectively. In April 2008, the size of the observatory staff decreased to a total of four staff members including the station chief. Therefore, the system now has less time available for satellite observations.

In 2009, we plan to replace the telescope, which has been in operation since 1982, with a new 75 cm diameter model. The telescope will be able to transmit and receive laser pulses in a common path. In addition, the photo-detector will be replaced.

Contact

Michihiro Suzuki, Chief
 Takashi Kurokawa, Deputy Chief
 Simosato Hydrographic Observatory
 1981 Simosato Nachi-katsuura Town
 Higashimuro District
 Wakayama Prefecture 649-5142
 JAPAN

Voice: +81-735-58-0084

E-mail: shimosato@kaiho.mlit.go.jp

Tanegashima, Japan

Takahiro Inoue, Shinichi Nakamura, Ryo Nakamura, Flight Dynamics Division, JAXA

Introduction

The Japan Aerospace Exploration Agency (JAXA) Satellite Laser Ranging system, GUTS-SLR (GMSL, Tanegashima), was completed in the spring of 2004. The GUTS-SLR, shown in Figure 13-79, is located on Tanegashima Island, the location of the Japanese launch site.

The GUTS-SLR is operated by remote control from the Tsukuba Space Center (TKSC). The distance between TKSC and the SLR station is approximately 1100 km. Routine SLR operations began on September 1, 2004.



Figure 13-79. GUTS-SLR system.

Facilities/Systems

GUTS-SLR is capable of ranging to satellites from low Earth orbit to geostationary orbit. The system can range to the LAGEOS satellites with a single-shot rms of less than 10 mm and less than 20 mm rms to ETS-8 (JAXA geostationary satellite). The GUTS-SLR station is primarily operated automatically using a predetermined schedule. An operator is needed to activate/deactivate the initial power supply, manually operate the initial acquisition when the orbit prediction has an error, and perform regular system maintenance. The station's Master Control and Operation Planning Subsystem (COPS) generates an operational plan for the entire GUTS system. This system also monitors the operational conditions of each subsystem.

Current Activities

GUTS-SLR continued routine ranging operations during 2007 and 2008. GUTS-SLR successfully participated in the SOHLA-1 tracking campaign; the system obtained intermittent returns due to the satellite spin. GUTS-SLR is now taking part in the ETS-8 tracking campaign for the High Accuracy Clock (HAC) experiment; this is the first time JAXA has successfully tracked a geostationary satellite using SLR.

Contacts

Shinichi Nakamura

Voice: +81-29-868-2625

E-mail: nakamura.shinichi@jaxa.jp

Ryo Nakamura

Voice: +81-29-868-2616

E-mail: nakamura.ryoh@jaxa.jp

Takahiro Inoue

Voice: +81-29-868-2627

E-mail: inoue.takahiro@jaxa.jp

Fax: +81-29-868-2990

Flight Dynamics Division

Consolidated Space Tracking and

Data Acquisition Department

Office of Space Flight and Operations, JAXA

JAPAN

Wetzell, Germany

Stefan Riepl/BKG

WLRS

Two lamp pumped laser heads of the Wetzell Laser Ranging System (WLRS) Nd:YAG laser were replaced with three-stage diode pumped laser heads. This upgrade has increased the stability and the reliability in service of the whole system in a significant way. The operating system has been upgraded with an automatic search routine. At the end of 2009, we will start equipping the WLRS telescope with new DC engines and encoders for elevation and azimuth. We are expecting a resumption of WLRS operations by May 2010.

SOS-W

The Satellite Observing System Wetzell (SOS-W) is meant to be a highly autonomous satellite laser ranging system, providing support especially for low earth orbiting satellites and enabling for kilohertz repetition rate lasers.

During 2007 and 2008 the control system software was completed following a new design strategy. The new software design features modularization at the server level and keeps a strict separation between operating tasks and the graphical user interface.

The event timing system has also undergone thorough tests within the Altimetry and Transponder Ground Simulation Demonstration (ALTIDEMON) experiment set up at the WLRS. It was completed in 2008 with the installation of two redundant operating Reference Generators, which enables referencing of GPS time and synchronization to the local timing systems.

The manufacturing process of the bistatic telescope was driven further during 2007 and the detector box developed in Wetzell has been integrated. The mechanical properties of the telescope mount have been verified during the factory acceptance test in December 2007. The telescope was accepted as ready for delivery in June 2008 giving way to the site installation in Wetzell during July 2008. The field acceptance and commissioning phase is expected to be finalized in June 2009. We anticipate that the system will begin routine operations in September 2009.



Figure 13-80: The SOS-W Telescope during factory acceptance test at Carl Zeiss Jena



Figure 13-81: Installation procedure of the SOS-W telescope in Wetzell.

Contact

Stefan Riepl
Bundesamt für Kartographie und Geodäsie
Fundamentalstation Wettzell
Sackenrieder Str. 25
D-93444 Kötzing
GERMANY

E-mail: stefan.riepl@bkg.bund.de
Voice: +49 (0) 9941 / 603-118
Fax: +49 (0) 9941 / 603-222

Yarragadee, Australia

Vince Noyes/EOS Space Systems Pty. Ltd.

General

During 2007, MOBLAS-5 at Yarragadee tracked a total of 12,289 passes that produced 221,564 normal points. In 2008, the data yield increased to 14,034 passes with 252,262 normal points. New satellites successfully tracked during the report period included ETS-8, GLONASS-102/-109, TerraSAR-X, Jason-2, ALOS, ANDERR-Active and -Passive, OICETS, and Compass-M1. MOBLAS-5 has continued to maintain top position for data collected during the report period.

NASA has installed a Tracking and Data Relay Satellite System (TDRSS) 400 meters from our laser station to assist their global coverage/management of orbiting satellites.



Figure 13-82. MOBLAS-5 SLR station staff (left to right): Randall Carman, Brian Rubery, Peter Bargewell, Vince Noyes, Jack Paff, and Peter Thomas.

System Upgrades and Faults

Our complete communication system was upgraded to a 64 bit dual Xeon Windows 2003 server in the late 2006/early 2007 timeframe. This was a significant upgrade and has served us well with limited trouble. NASA/HTSI supplied a new controller PC, which was installed by the local crewmembers; after a debugging period of six months, the new system is now performing to expectations. A new Digital Phosphor oscilloscope was installed in the laser room with a second unit now used as the tracking scope. This configuration has resulted in a more eye-friendly tracking environment due to the bright display. The 30-year-old modular precision angular control system (MPACS) is still working but is starting to show its age with intermittent faults. A small crack in the front window of our telescope has not changed in length over the last two years.

Geoscience Australia conducted a complete five-day local survey in May 2007 and found no major movement between our local ties.

Guest Equipment Upgrades

Geoscience Australia upgraded their GPS instrument to a LEICA 1200 receiver and installed a new UPS and associated computer equipment. A new DORIS beacon and supporting computer equipment were installed in September 2007 on behalf of CNES.

Future Plans for the Site

NASA/HTSI intends to upgrade the laser system by installing a new table and chiller unit and replacing the flowing dye cell with a saturable absorber unit. The MCP will also be replaced during this period to bring us up to date with the other MOB LAS stations. NASA's Next Generation SLR system is planned for co-location testing at our site in late 2010 or early 2011.

Geoscience Australia intends to install a 12-meter antenna at the Yarragadee site for VLBI work. This project is underway with a planned completion date by early 2010.

Contacts

EOS Space Systems Pty Limited
P.O. Box 137
Dongara, Western Australia 6525
AUSTRALIA

E-mail: moblas@midwest.com.au

Ron Thompson
Electro Optic Systems Pty Limited
111 Canberra Avenue
Griffith ACT 2603
AUSTRALIA

Voice: + 61-2-6222-7999
Fax: + 61-2-6299-7687
E-mail: ronthompson@eos-aus.com

Zimmerwald, Switzerland

Werner Gurtner, Eugen Pop, Johannes Utzinger, Martin Ploner/Astronomical Institute of Bern



Figure 13-83: The Zimmerwald Observatory

Evaluation and Installation of a New Laser System

In the years 2006 and 2007 we evaluated and ordered a new laser system to replace our Titanium:Sapphire laser having been in operation for more than ten years. The main characteristics of the new system are summarized in Table 13-5.

Table 13-5. Major Characteristics of the Zimmerwald Laser System

Manufacturer:	Thales Laser, France
Technology:	Diode pumped solid state Nd:YAG laser
Pulse generation:	SESAM technology (SEmiconductor Saturable Absorber Mirror)
Configuration:	Time Bandwidth Oscillator, regenerative amplifier, double-pass amplifier
Wavelengths:	1064 + 532 nm
Pulse rate:	90-110 Hz, adjustable with external trigger; additional decimation possible
Pulse energy:	21 mJ @ 1064 nm before doubling, 9 mJ @ 532 nm
Pulse width:	58 ps (FWHM)
Pulse contrast:	< 1/200
Beam diameter:	8 mm
Stability of energy:	< 1%
Pointing stability:	< 5 arc sec

A selectable ratio of the infrared laser beam (usually 100%) is passed through a second harmonic generation (SHG). The resulting beam at the 532 nm wavelength can be attenuated for terrestrial calibration or for the tracking of vulnerable satellites. On the other hand, part or all of the infrared beam can bypass the SHG for infrared only or dual-color measurements, depending on the availability of suitable infrared detectors.

A PC card with a field programmable gate array (FPGA), built and programmed by F. Koidl, TU Graz, provides control signals to trigger the pump diodes and Pockels cells, to drive the rotating shutter, and to generate range gate windows.

The laser was ordered in spring 2007 and delivered and installed in March 2008.

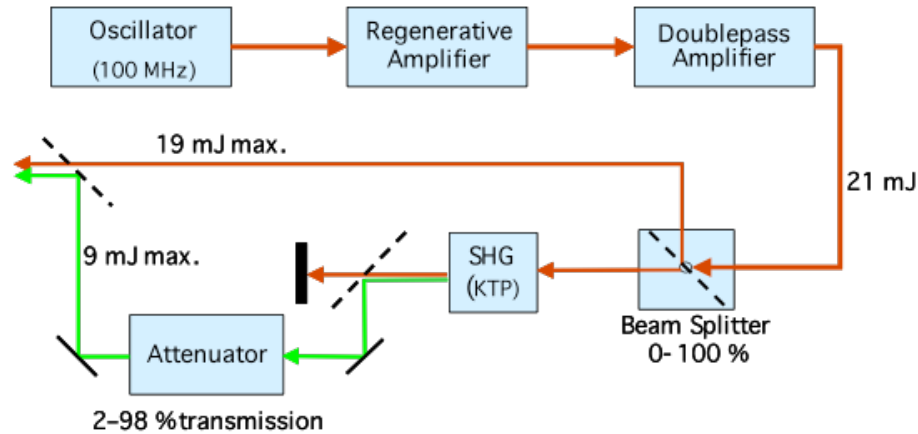

Figure 13-84: Main Laser Components

First Experiences

Single-shot precision of the new system turns out to be of the order of 5 mm in single-photon mode (Figure 13-85).

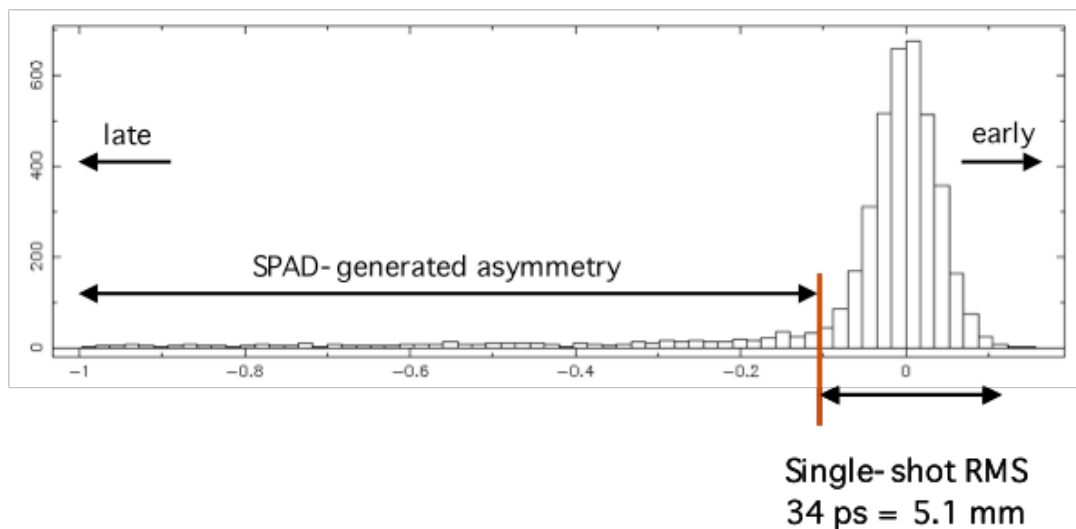
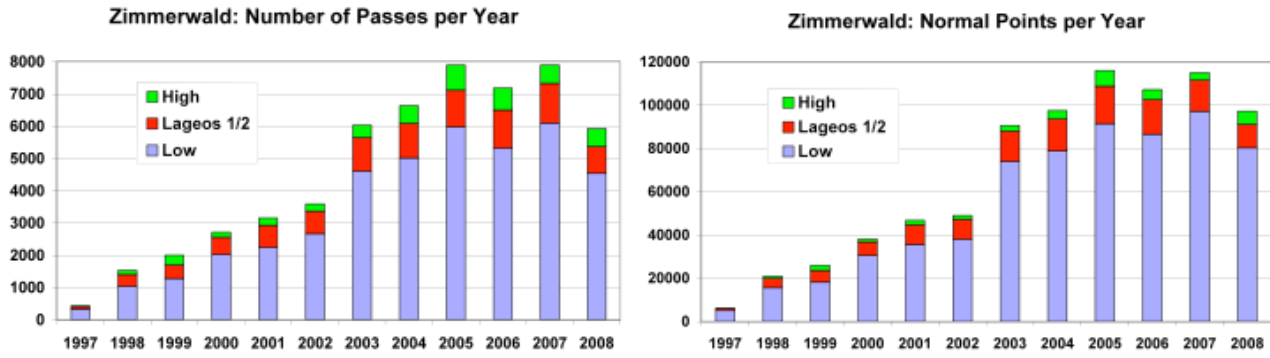

Figure 13-85. CHAMP satellite: Distribution of returns

Suffering from a three-month break in 2008 (the old laser was fatally damaged at the end of January 2008; operation with the new laser resumed at the end of April) Zimmerwald could not quite maintain its performance of the previous years regarding the number of successfully tracked passes (Figure 13-86). However, the new laser promises to be a very reliable and efficient operation for the Zimmerwald system and it offers the necessary flexibility to adjust the system to new requirements, especially in view of future one-way ranging and transponder experiments.



Figures 13-86a and -86b: Number of passes and normal points per year

Contact

Werner Gurtner
 Astronomical Institute
 University of Bern
 Sidlerstrasse 5
 CH-3012 Bern
 SWITZERLAND

Voice: +41.31.6318599 (Institute)
 Voice: +41.31.8190050 (Observatory)
 Fax: +41.31.6313869
 E-mail: werner.gurtner@aiub.unibe.ch

APPENDIX



FRASER PANGLOSS



APPENDIX

ILRS INFORMATION

ILRS Contributing Organizations

Agency	Country
National University of San Juan of Argentina	Argentina
Geoscience Australia	Australia
EOS Space Systems Pty. Ltd.	Australia
Austrian Academy of Sciences	Austria
Central Laboratory for Geodesy, Bulgarian Academy	Bulgaria
Observatorio Geodetico TIGO, Universidad de Concepción	Chile
Academia Sinica	China
Chinese Academy of Sciences (CAS)	China
Chinese Academy of Surveying and Mapping (CASM)	China
Institute of Seismology, China Seismological Bureau	China
National Astronomical Observatories of China (NAOC)	China
Shanghai Astronomical Observatory (SAO)	China
State Seismological Bureau	China
Yunnan Observatory	China
Technical University of Prague	Czech Republic
National Research Institute of Astronomy and Geophysics (NRIAG)	Egypt
Finnish Geodetic Institute	Finland
Centre National d'Etudes Spatiales (CNES)	France
Groupe de Recherches de Geodesie Speciale (GRGS)	France
Institut Géographique National (IGN)	France
Observatoire de la Côte d'Azur/Center d'Etudes et de Recherches Géodynamiques et Astrométrie (OCA/CERGA)	France
Observatoire de Paris	France
Tahiti Geodetic Observatory, University of French Polynesia (UFP)	French Polynesia
Bundesamt für Kartographie und Geodäsie (BKG)	Germany
Deutsches Geodätisches ForschungsInstitut (DGFI)	Germany
European Space Agency (ESA)	Germany
Forschungseinrichtung SatellitenGeodasie/Institut fuer Erdmessung (FESG/IFE)	Germany
Helmholtz Centre Potsdam GeoForschungsZentrum German Research Centre for Geosciences (GFZ)	Germany
University of Hannover/Institut fuer Erdmessung	Germany

ILRS Contributing Organizations continued

Agency	Country
Agenzia Spaziale Italiana (ASI)	Italy
Hitotsubashi University	Japan
Hydrographic Department/Japan Coast Guard	Japan
Japan Aerospace Exploration Agency (JAXA)	Japan
National Institute of Information and Communications Technology (NICT)	Japan
Astronomical Institute, University of Latvia	Latvia
Delft University of Technology (DUT)	The Netherlands
Division for Electronics, Forsvarets ForskningsInstitutt (FFI)	Norway
Universidad Nacional de San Augustin (UNSA)	Peru
Space Research Center of the Polish Academy of Sciences (PAS)	Poland
Institute of Applied Astronomy (IAA)	Russia
Institute of Astronomy of the Russian Academy of Sciences (INASAN)	Russia
Institute of Metrology for Time and Space (IMVP)	Russia
Information-Analytical Center (IAC)/Mission Control Center (MCC)	Russia
Russian Space Agency (RSA)	Russia
Space Research Institute (SRI) for Precision Instrument Engineering	Russia
King Abdulaziz City for Science and Technology (KACST)	Saudi Arabia
Hartebeesthoek Radio Astronomy Observatory (HartRAO)	South Africa
Real Instituto y Observatorio de la Armada	Spain
Astronomical Institute, University of Berne (AIUB)	Switzerland
Astronomical Observatory of the Ivan Franko National University of Lviv	Ukraine
Scientific Research Institute (SRI) Crimean Astronomical Observatory	Ukraine
Lebedev Physical Institute in the Crimea	Ukraine
Main Astronomical Observatory (MAO) of the National Academy of Sciences of Ukraine (GAOUA)	Ukraine
Natural Environment Research Council (NERC)	United Kingdom
Newcastle University	United Kingdom
Harvard-Smithsonian Center for Astrophysics	USA
Jet Propulsion Laboratory (JPL)	USA
Joint Center for Earth System Technology (JCET), University of Maryland, Baltimore County (UMBC)	USA
National Aeronautics and Space Administration Goddard Space Flight Center (NASA GSFC)	USA
Naval Research Laboratory (NRL)	USA
University of Hawaii Institute for Astrometry	USA
University of Texas at Austin	USA
University of Texas, Center for Space Research (CSR)	USA

List of Acronyms

3D-ART	Three-Dimensional Ray Tracing
	◆ ◆ ◆
AAC	Associate Analysis Center
AC	Analysis Center
ACES	Atomic Clock Ensemble in Space
ACT	Australian Capital Territory
ADEOS	Advanced Earth Observing Satellite
AG	Absolute Gravimeter
AGU	American Geophysical Union
AIRS	Atmospheric Infrared Sounder (USA)
AIUB	Astronomical Institute of Berne (Switzerland)
ALOS	Advanced Land Observing Satellite
Alt/Az	Altitude/Azimuth
ALTIDEMON	Altimetry and Transponder Ground Simulation Demonstration (Germany)
ANDE	Atmospheric Neutral Density Experiment (USA)
ANDE-RR	Atmospheric Neutral Density Experiment Risk Reduction (USA)
ANSI	American National Standards Institute
ANU	Australian National University
AOM	Acousto-Optic Modulator
APD	Avalanche Photodiodes
APOLLO	Apache Point Observatory Lunar Laser-ranging Operation (USA)
AQ-SPAD	Actively-Quenched Single Photoelectron Avalanche Detector
ARB	Average Per Year Range Bias
ARTEMIS	Advanced Relay And Technology Mission
ASI	Agenzia Spaziale Italiana (Italian Space Agency)
ASTRO-G	Astronomy Satellite-G (Japan)
AVNIR	Advanced Visible Near-Infrared Radiometer (Japan)
AWG	Analysis Working Group
Az-El	Azimuth-Elevation
	◆ ◆ ◆
BAS	Bulgarian Academy of Sciences
BE-C	Beacon Explorer C
BELA	BepiColombo Laser Altimeter
BIPM	International Bureau of Weights and Measures
BIU	Beijing Industrial University
BKG	Bundesamt für Kartographie und Geodäsie (Germany)
BLITS	Ball Lens In The Space (Russia)
BNSC	British National Space Center
BSW	Bernese Software
	◆ ◆ ◆
Cal/Val	Calibration/Validation
CAMAC	Computer Automated Measurement And Control
CAS	Chinese Academy of Sciences
CASM	Chinese Academy of Surveying and Mapping
CB	Central Bureau
CC	Combination Center
CCD	Charge-Coupled Device
CCR	Corner Cube Reflector

CDDIS	Crustal Dynamics Data Information System (USA)
CEG	School of Engineering and Geosciences, Newcastle University (UK)
CERGA	Centre d'Etudes et de Recherches Géodynamiques et Astrométrie (France)
CfA	Center for Astrophysics (USA)
CFD	Constant-Fraction Discriminator
CGS	Centro di Geodesia Spaziale (Italy)
CHAMP	CHALLENGING Mini-Satellite Payload
CLG	Central Laboratory for Geodesy (Bulgaria)
CLS	Collecte, Localisation, Satellites (France)
CMD	Constant Mid-signal Detection
CMONOC	Crustal Movement Observation Network of China
CNES	Centre National d'Etudes Spatiales (France)
CNS	Communication, Navigation and Surveillance
CODE	Center for Orbit Determination in Europe
CoM	Center of Mass
COPs	Control Operation Planning Subsystem (Japan)
COPS	Control and Operation Planning Subsystem
COSPAR	Committee on Space Research
CPF	Consolidated Prediction Format
CPP	Combination Pilot Project
CRD	Consolidated Laser Ranging Data format
CRDF	Civilian Research and Development Foundation (USA)
CRF	Celestial Reference Frame
CRL	Communications Research Laboratory (Japan)
CSPAD	Compensated Single Photoelectron Avalanche Detector
C-SPAD	Compensated Single Photoelectron Avalanche Detector
CSR	Center for Space Research (USA)
CSRIFS	Combined Square Root Information Filter and Smoother (Finland)
CSTG	International Coordination of Space Techniques for Geodesy and Geodynamics
CTC	Cross Track Channel
CTU	Czech Technical University (Czech Republic)

◆ ◆ ◆

DEM	Digital Elevation Model
DEOS	Department of Earth Observation (The Netherlands)
DESDynI	Deformation, Ecosystem Structure and Dynamics of Ice (USA)
DFG	German Research Foundation
DGFI	Deutsches Geodätisches Forschungsinstitut (Germany)
DIMM	Differential Image Motion Monitor
DLR	German Aerospace Center
DoD	Department of Defense (USA)
DOE	Diffraction Optical Element
DOGS	DGFI Orbit and Geodetic Parameter Estimation Software
DOP	Dilution of Precision
DORIS	Doppler Orbitography and Radiopositioning Integrated by Satellite
DPSSL	Diode Pumped Solid State Laser
DREAM	Dual-channel Radiometer for Earth and Atmosphere Monitoring (Korea)
DTOF	Differential Time of Flight
DUT	Delft University of Technology (The Netherlands)

◆ ◆ ◆

ECMWF	European Centre for Medium-Range Weather Forecasts (UK)
EDC	EUROLAS Data Center (Germany)
EGU	European Geophysical Union
EMCCD	Electron Multiplying Charge Coupled Device
EO	Earth Observation
EOP	Earth Orientation Parameter
EOS	Earth Observing System (USA)
EOS	Electro Optical Systems (USA)
EOST	EOS Technologies, Inc. (Australia)
ERP	Earth Rotation Parameter
ERP	Effective Reflecting Plane
ERS	European Remote Sensing Satellite
Er:YAG	Erbium Yttrium Aluminum Garnet
ESA	European Space Agency
ESOC	ESA Space Operations Center
ET	Event Timer
ETH	Eidgenössische Technische Hochschule/Swiss Federal Institute of Technology (Switzerland)
ETS	Engineering Test Satellite
EU	European Union
EUMETSAT	European Organization for the Exploitation of Meteorological Satellites
EUREFIAG	Reference Frame Sub-Commission for Europe
EUROLAS	European Laser Consortium
	◆ ◆ ◆
FAA	Federal Aviation Administration (USA)
FESG	Forschungseinrichtung Satellitengeodäsie (Research Facility for Space Geodesy, Germany)
FFI	Forsvarets Forskningsinstitutt (Norwegian Defense Research Establishment)
FNSPE	Faculty of Nuclear Sciences and Physical Engineering (Czech Republic)
FOV	Field Of View
FPGA	Field Programmable Gate Array
FTLRS	French Transportable Laser Ranging System
FTP	File Transfer Protocol
FWHM	Full Width at Half Maximum
	◆ ◆ ◆
GA	Geoscience Australia
GaAsP	Gallium Arsenide Photo Diode
GAOUA	Main Astronomical Observatory of the National Academy of Sciences of Ukraine
GB	Gigabyte
GeoDAF	Geodetic Data Archive Facility (Italy)
GEO	Group on Earth Observations
GEOS	Geodetic and Earth Orbiting Satellite
GEOSS	Global Earth Observation System of Systems
GFO	GEOSAT Follow-On (USA)
GFZ	GeoForschungsZentrum (Germany)
GGAO	Goddard Geophysical and Astronomical Observatory (USA)
GGM	Global Gravitational Model
GGOS	Global Geodetic Observing System
GGOS-D	Global Geodetic Observing System German Component
GIA	Glacial Isostatic Adjustment
GIOVE	Galileo in Orbit Validation Experiment
GIUB	Geographische Institut der Universität Bonn (Germany)

GLAS	Geoscience Laser Altimeter System (USA)
GLONASS	Global Navigation Satellite System
GLONASS	Global'naya Navigatsionnay Sputnikovaya Sistema
GM	Gravitational Constant
GNSS	Global Navigation Satellite System
GOCE	Gravity Field and Steady-state Ocean Circulation Explorer
GP-B	Gravity Probe B
GPS	Global Positioning System
GPSR	GPS Receiver
GRACE	Gravity Recovery And Climate Experiment
GRGS	Groupe de Recherches de Geodesie Speciale (France)
GSFC	Goddard Space Flight Center (USA)
GSTB	Galileo System Test Bed
GUTS	Global and High Accuracy Trajectory Determination System



H2A/LRE	Laser Ranging Experiment
HAC	High Accuracy Clock
HartRAO	Hartebeesthoek Radio Astronomy Observatory (South Africa)
HEO	High Earth Orbiter
HIT-U	Hitotsubashi University (Japan)
HOLLAS	Haleakala Laser Station (USA)
HP	Hewlett-Packard
HTSI	Honeywell Technology Solutions, Inc. (USA)
HV	High Voltage
HVAC	Heating, Ventilation, and Air Conditioning
HxET	Herstmonceux Event Timer
Hz	Hertz



IAA	Institute of Applied Astronomy (Russia)
IAC	Information-Analytical Center (Russia)
IAG	International Association of Geodesy
IAPG/TUM	Institute of Astronomical and Physical Geodesy of the Technische Universität München (Germany)
IAPSO	International Association for the Physical Sciences of the Oceans
IA/RAS	Institute of Astronomy/Russian Academy of Sciences
IAU	International Astronomical Union
ICCD	Intensified Charged Coupled Device
ICESat	Ice Cloud and Land Elevation Satellite
ICET	International Center for Earth Tides
ICRF	International Celestial Reference Frame
ICRS	International Celestial Reference System
IDS	International DORIS Service
IEEE	Institute of Electrical and Electronics Engineers
IERS	International Earth Rotation and Reference Systems Service
IFE	Institut für Erdmessung (Germany)
IGeS	International Geoid Service
IGFS	International Gravity Field Service
IGGOS	Integrated Global Geodetic Observing System
IGLOS	International GLONASS Service
IGN	Institut Geographique National (France)

IGOS	Integrated Global Observing Strategy
IGS	International GNSS Service
ILRS	International Laser Ranging Service
ILRSA	ILRS A solution
ILRSB	ILRS B solution
IMVP	Institute of Metrology for Time and Space (Russia)
INASAN	Institute of Astronomy of the Russian Academy of Sciences
InGaAs	Indium-Gallium-Arsenide
INGV	Istituto Nazionale di Geofisica (Italy)
InSAR	Interferometric Synthetic Aperture Radar
IOV	In Orbit Validation
IPIE	Science Research Institute for Precision Instrument Engineering (Russia)
IR	Infrared
IRS	Indian Research Satellite
IRV	Inter-Range Vector
ISRO	Indian Space Research Organization
ISTRAC	ISRO Telemetry Tracking and Command Network (India)
ITRF	International Terrestrial Reference Frame
ITRS	International Terrestrial Reference System
IUGG	International Union of Geodesy and Geophysics
IVS	International VLBI Service for Geodesy and Astrometry
	◆ ◆ ◆
JAXA	Japan Aerospace Exploration Agency
JCET	Joint Center for Earth Systems Technology (USA)
JGM	Joint Gravity Model
JGR	Journal of Geophysical Research
JIVE	Joint Institute for VLBI for Europe
JPL	Jet Propulsion Laboratory (USA)
	◆ ◆ ◆
KAIST	Korea Advanced Institute of Science and Technology
KASI	Korean Astronomy and Space Science Institute
KACST	King Abdulaziz City for Science and Technology (Saudi Arabia)
kHz	Kilohertz
Km	Kilometer
KOMPSAT	Korean Multi-Purpose Satellite
KSLV	Korea Space Launch Vehicle
	◆ ◆ ◆
LAGEOS	LAser GEOdynamics Satellite
LAREG	Laboratoire de Recherches en Géodésie (France)
LARES	Laser Relativity Satellite
LE	Leading Edge
LEO	Low Earth Orbit
LLR	Lunar Laser Ranging
LNU	Lviv National University (Ukraine)
LOD	Length Of Day
LOLA	Lunar Orbiter Laser Altimeter
LOS	Loss Of Signal
LOSSAM	LAGEOS Spin Axis Model
LOSTHERM	LageOS THERmal Model

LR	Laser Ranging
LRA	Laser Retroreflector Array
LRE	Laser Retroreflector Experiment
LRO	Lunar Reconnaissance Orbiter
LRO-LR	Lunar Reconnaissance Orbiter Laser Ranging
LRR	Laser Retro Reflector
LRRA	Laser Retro Reflector Array
LTT	Laser Time Transfer
LURE	LUnar Ranging Experiment



MAO	Main Astronomical Observatory (Ukraine)
MCC	Mission Control Center (Russia)
MCP	Micro Channel Plate
MeO	Meteorology and Optics (France)
MEO	Medium Earth Orbit
MESSENGER	MERCURY Surface, Space ENVIRONMENT, GEOchemistry, and Ranging
MF	Mapping Function
MFC	Microsoft Foundation Class
MGS	Mars Global Surveyor
MHz	Megahertz
MIT	Massachusetts Institute of Technology (USA)
MLA	Mars Laser Altimeter
MLRO	Matera Laser Ranging Observatory (Italy)
MLRS	McDonald Laser Ranging System (USA)
MRR	Modulated Retro-Reflectors
MO	Master Oscillator
MOBLAS	MOBILE LASER Ranging System
MOE	Medium Orbit Ephemerides
MOLA	Mars Orbiter Laser Altimeter
MOPA	Master Oscillator Power Amplifier
MSTA	Ministry of Science and Technology of Argentina
MSTC	Ministry of Science and Technology of China
MTLRS	Modular Transportable Laser Ranging System



NAO	National Astronomical Observatories (China)
NAOC	National Astronomical Observatories of Chinese Academy of Sciences
NASA	National Aeronautics and Space Administration (USA)
NASDA	National Space Development Agency (Japan)
NAS	National Academy of Sciences (Ukraine)
NASU	National Academy of Sciences of Ukraine
NCEP	National Centers for Environmental Prediction (USA)
NCL	Newcastle University (UK)
NCRIEO	North China Research Institute of Electro-Optics
NCST	Naval Center for Space Technology (USA)
Nd:VAN	Neodymium Vanadate
Nd:YAG	Neodymium Yttrium Aluminum Garnet
Nd:YLF	Neodymium: Yttrium Lithium Fluoride
NEAR	Near Earth Asteroid Rendezvous
NEOS	National Earth Orientation Service (USA)
NERC	Natural Environment Research Council (UK)

NGA	National Geospatial-Intelligence Agency (USA)
NGSLR	Next Generation Satellite Laser Ranging System (USA)
NICT	National Institute of Information and Communications Technology (Japan)
NOAA	National Oceanic and Atmospheric Administration (USA)
NP	Normal Point
N-PET	New Precision Event Timer
NPET	New Pico Event Timer
NPOESS	National Polar-orbiting Operational Environmental Satellite System
NRIAG	National Research Institute of Astronomy and Geophysics (Egypt)
NRL	Naval Research Laboratory (USA)
NSF	National Science Foundation (USA)
NSGF	NERC Space Geodesy Facility (UK)
NTUA	National Technical University of Athens (Greece)
NUSJA	National University of San Juan of Argentina

◆ ◆ ◆

OCA	Observatoire de la Côte d'Azur (France)
OGT	Observatoire Géodésique de Tahiti (French Polynesia)
OICETS	Optical Inter-orbit Communications Engineering Test Satellite (Japan)
OSTM	Ocean Surface Topography Mission

◆ ◆ ◆

PALSAR	Phased Array L-band Synthetic Aperture Radar (Japan)
Pan-STARRS	Panoramic Survey Telescope and Rapid Response System (USA)
PAS	Polish Academy of Sciences
PCA	Point of Closest Approach
PCI	Peripheral Component Interface
PDF	Portable Document Format
PI	Principal Investigator
PM	Passive Modelocker
PMSL	Permanent Service for Mean Sea Level
PMT	Photo Multiplier Tube
POD	Precision Orbit Determination
POE	Precise Orbit Ephemerides
POL	Proudman Oceanographic Laboratory (UK)
POLAC	Paris Observatory Lunar Analysis Center (France)
PPET	Portable Pico-Second Event Timer
PPN	Parameterized Post Newtonian
PQ-SPAD	Passively Quenched Single Photoelectron Avalanche Detector
PRARE	Precise Range and Range-rate Equipment
PRISM	Panchromatic Remote-sensing Instrument for Stereo Mapping (Japan)
PROBA	Project for On-Board Autonomy
PTM	Pulse Transmission Mode

◆ ◆ ◆

QC	Quality Control
Q/C	Quality Control
QE	Quantum Efficiency
QZS	Quasi-Zenith Satellite
QZSS	Quasi-Zenith Satellite System

◆ ◆ ◆

R&D	Research and Development
RAS	Russian Academy of Sciences
RGG	Range Gate Generator
RGO	Royal Greenwich Observatory (UK)
RINEX	Receiver Independent Exchange format
RIS	Reflector In Space
RLEP	Robotic Lunar Exploration Program (USA)
RMS	Root Mean Square
ROA	Real Instituto y Observatorio de la Armada (Spain)
RRA	Retro Reflector Array
RSA	Russian Space Agency
RSG	Refraction Study Group
◆ ◆ ◆	
SAGE	Strategic Aerosol and Gas Experiment
SALRO	Saudi Arabian Laser Ranging Observatory
SAM	Saturable Absorber Mirror
SAO	Shanghai Astronomical Observatory (China)
SAO	Smithsonian Astrophysical Observatory (USA)
SAR	Synthetic Aperture Radar
SAW	Surface Acoustic Wave
SCEG	School of Civil Engineering and Geosciences (UK)
SESAM	SEmiconductor Saturable Absorber Mirror
SGF	Space Geodesy Facility (UK)
SGT	Stinger Ghaffarian Technologies, Inc. (USA)
SINEX	Software Independent Exchange Format
SIRAL	SAR/Inteferometric Radar Altimeter
SLR	Satellite Laser Ranging
SLRP	Satellite Laser Ranging Processor
SNR	Signal-to-Noise Ratio
SOD	Site Occupation Designator
SOHLA	Space Oriented Higashiosaka Leading Association (Japan)
SOS-W	Satellite Observing System-Wettzell (Germany)
SOVT	System Operational Verification Test
SP3	Standard Product 3 (satellite orbit format)
SPAD	Single Photoelectron Avalanche Detector
SPIE	International Society for Optical Engineering
SPWG	Signal Processing Working Group
SRI	Scientific Research Institute (Russia)
SRIF	Square Root Information Filter
SSC	Set of Station Coordinates
SSV	Set of Station Velocities
SSN	Space Surveillance Network (USA)
SST	Satellite-to-Satellite Tracking
SSTL	Surrey Satellite Technology Ltd. (UK)
STSAT	Science and Technology Satellite (Korea)
◆ ◆ ◆	

T2L2	Time Transfer by Laser Link
TC	Timer and Counter
TCE	Time Compare Equipment
TDC	Time-to-Digital Converter
TIGO	Transportable Integrated Geodetic Observatory
TIRV	Tuned Inter-Range Vector
Ti:Sap	Titanium Sapphire
Ti:Sapphire	Titanium Sapphire
TIU	Time Interval Unit
TKSC	Tskuba Space Center (Japan)
TLRS	Transportable Laser Ranging System
TOF	Time-Of-Flight
TOPEX	Ocean TOPography Experiment
ToR	Terms of Reference
TOR	Tracking, Occultation and Ranging
T/P	TOPEX/Poseidon
T/R	Transmit/Receive
TRF	Terrestrial Reference Frame
TROS	TRansportable Observation Station
TROS	Transportable Range Observation System
TTS	Transit Time Spread
TTS	Triple Threshold Screening
TM	Technische Universität München (Germany)
TUP	Technical University of Prague (Czech Republic)
	◆ ◆ ◆
UAW	Unified Analysis Workshop
UB	Ukraine Branch
UCSD	University of California San Diego (USA)
UFP	Université de la Polynésie Française (French Polynesia)
UK	United Kingdom
UMBC	University of Maryland Baltimore County (USA)
UNAVCO	University NAVSTAR Consortium
UNESCO	United Nations Education, Scientific and Cultural Organization
UNSA	Universidad Nacional de San Augustin (Peru)
UPF	University of French Polynesia
UPS	Uninterruptible Power Supply
URL	Uniform Resource Locator
USA	United States of America
UT	University of Texas
UTC	Universal Coordinated Time
UV	Ultraviolet
	◆ ◆ ◆
VLBI	Very Long Baseline Interferometry
	◆ ◆ ◆

WDC World Data Center
WDGPS Wide-area Differential Global Positioning System
WESTPAC Western Pacific Laser Tracking Network Satellite
WG Working Group
WLRS Wettzell Laser Ranging System (Germany)
WPLTN Western Pacific Laser Tracking Network
WRMS Weighted Root Mean Squared



XML Extensible Markup Language



YAG Yttrium Aluminum Garnet
Yt:YAG Ytterbium Yttrium Aluminum Garnet



ZD Zenith Delay

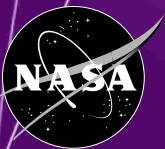

International Laser Ranging Service