

SVM PZ PANEL ONLY

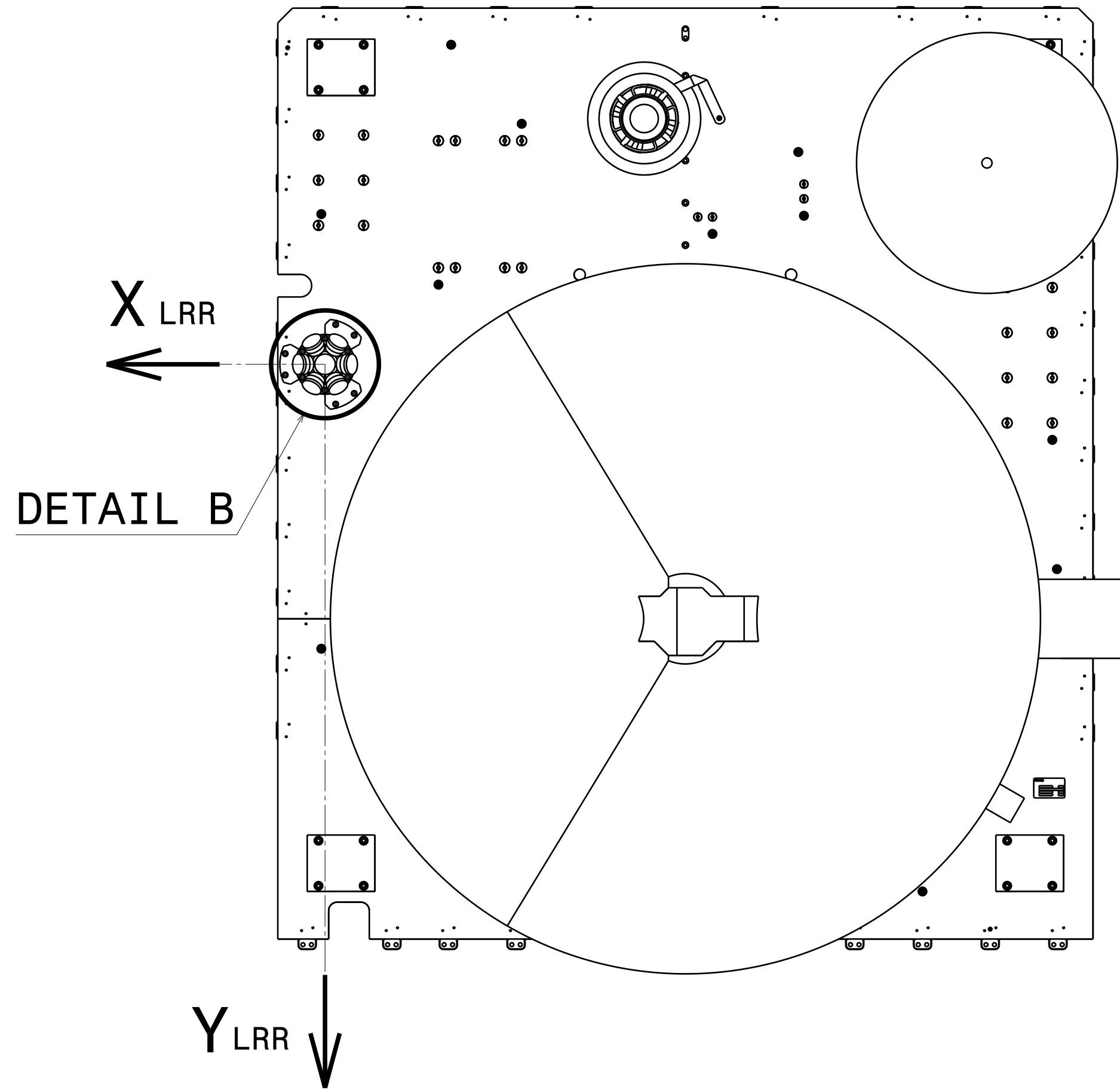

DETAIL A
SCALE: 1:2

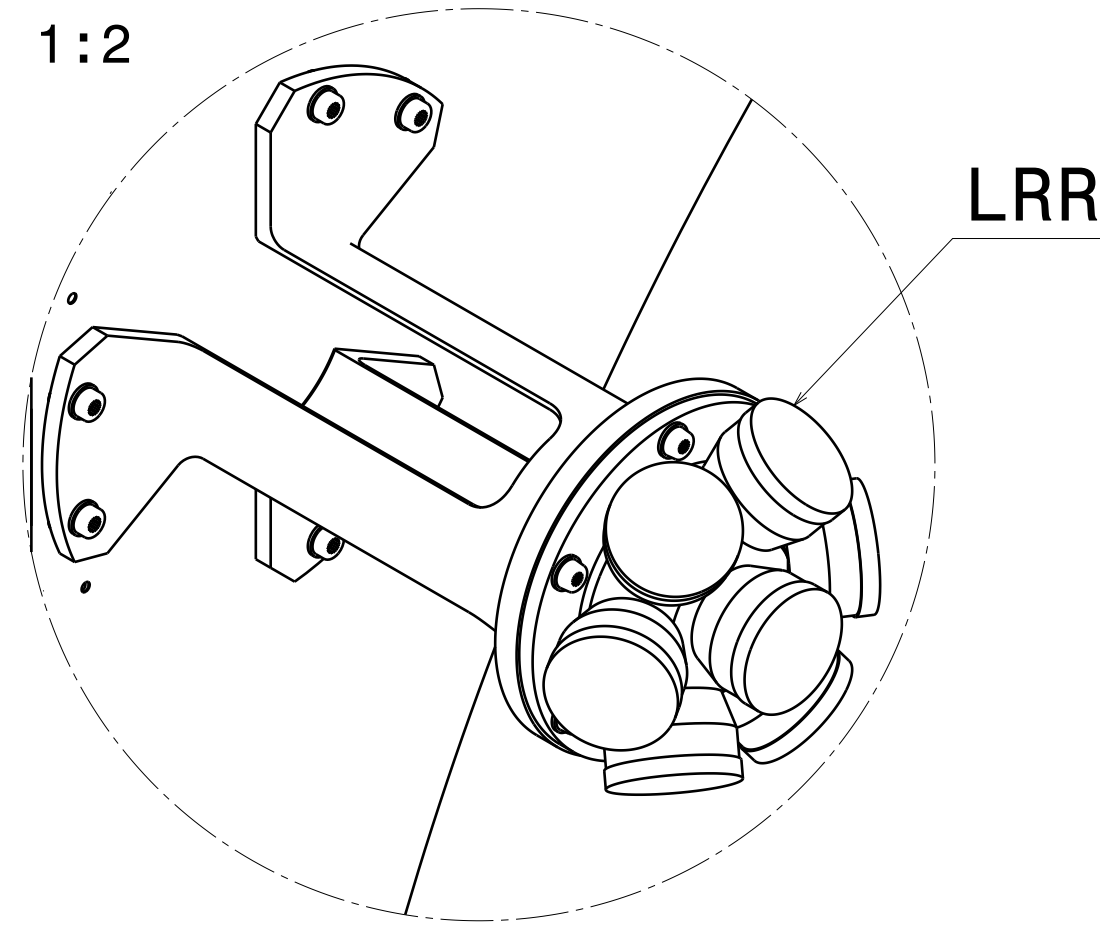

SECTION C-C
SCALE: 1:1

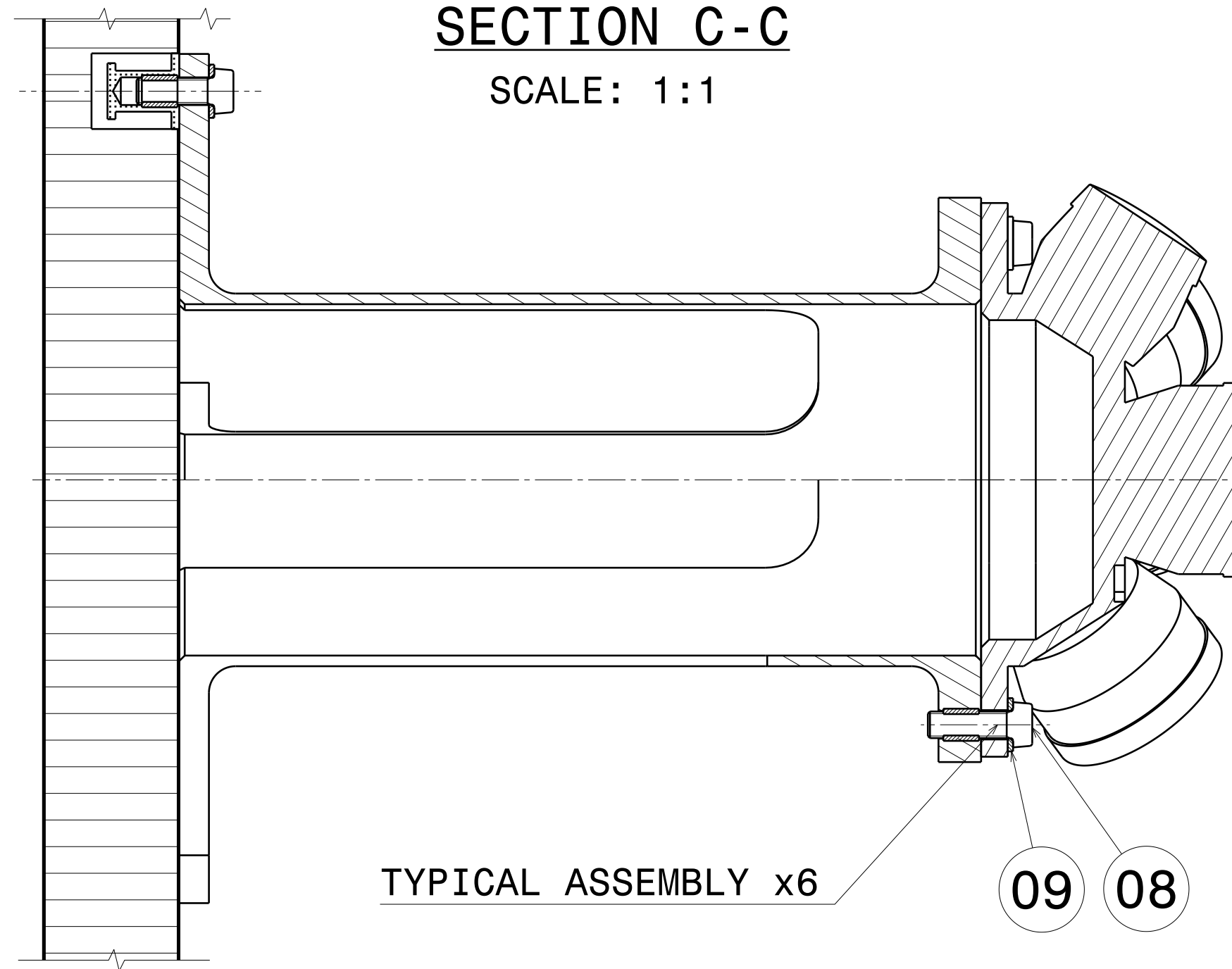

ISOMETRIC VIEW

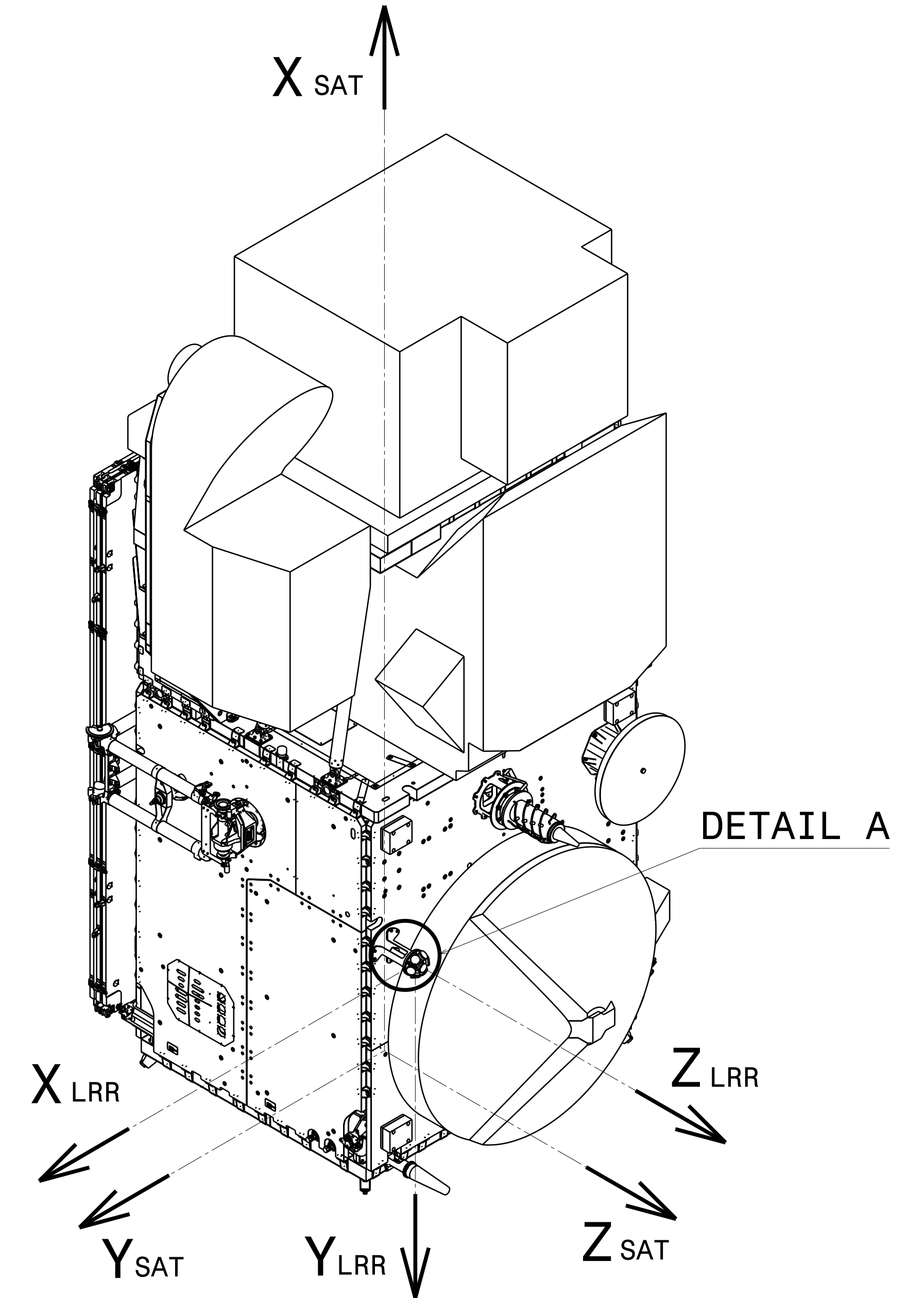

DETAIL B
SCALE: 1:1

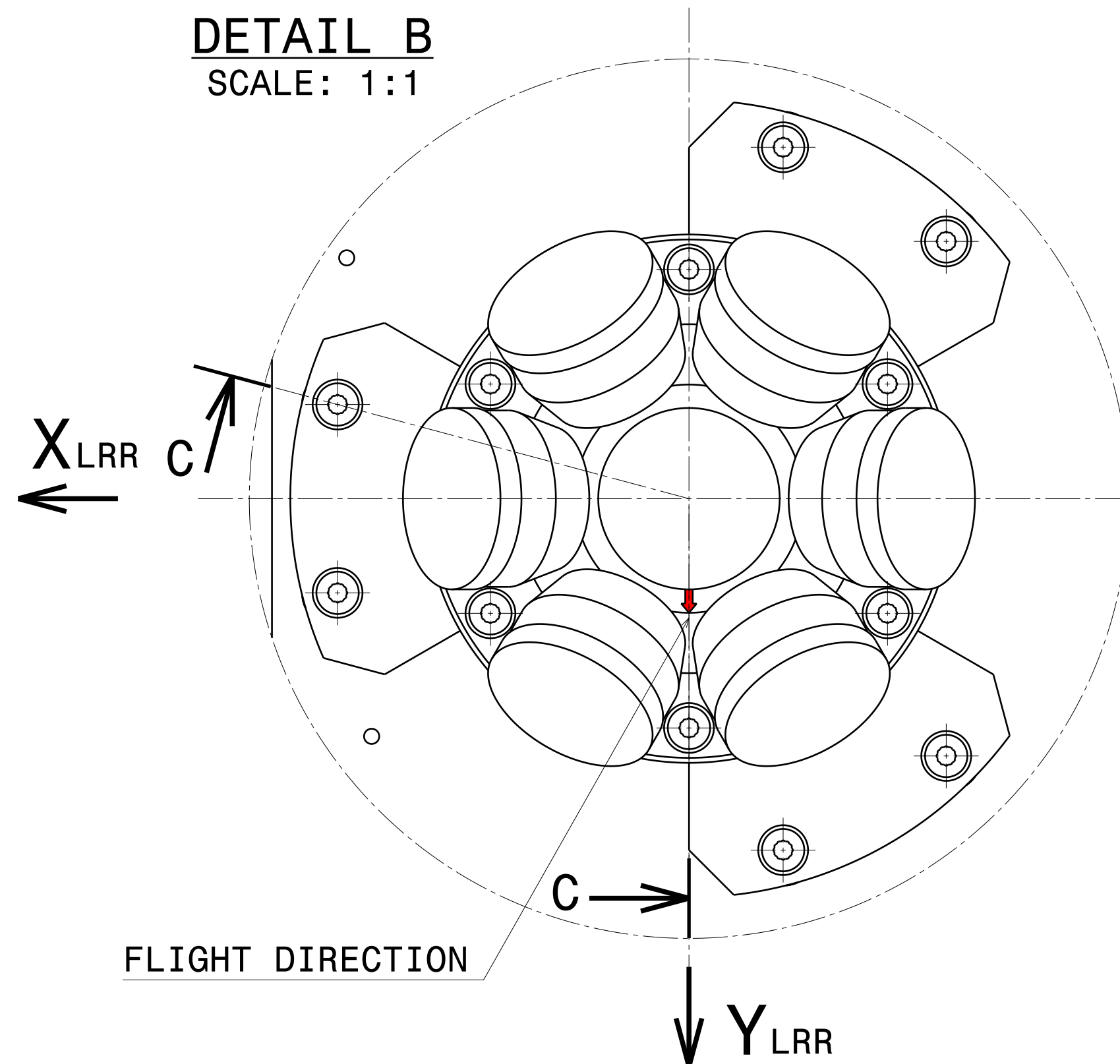

NOTA:

APPLICABLE DRAWING:

- LRR: K01-3391-00-00-Г4
- TERTIARY STRUCTURE: Z756150-000C

1- THE SEATING TORQUE APPLICABLE FOR THE SCREWS IS PROVIDED IN THE TABLE BELOW. THE LOCKING TORQUE SHALL BE ADDED TO THIS VALUE

MOUNTING	THREAD	TORQUE (Nm)
SCREW FOR UNIT MOUNTING	MJ5	6.5 ± 0.3Nm

2- THE INSERT / HELICOILS ARE SELF-LOCKING TYPE.

3- THE LOCKING (OR RUNNING) TORQUE SHALL MONITORED AS PER ITEM S3-UM-OSZ-SC-0005. (STRUCTURE USER MANUAL) AND THE PEAK VALUE SHALL BE RECORDED FOR EACH SCREW.

		S/C REFERENCE FRAME		
		X sat	Y sat	Z sat
LRR	LRR FRAME ORIGIN	1133.88	638.425	800.55
	X LRR	0	+1	0
	Y LRR	-1	0	0
	Z LRR	0	0	+1

COMPLEMENT MODIFICATION

DEMANDE	IND	MODIFICATION	EXECUTANT	DATE

TOLERANCES GENERALES DE FABRICATION: -PROFIL ISO NF L 05220, -TOLERANCES NF L 05223, -FILETAGE 4 H -TARAUDAGE 5 H

TOLERANCES SUR LES FILETAGES: -PROFIL ISO NF L 05220, -TOLERANCES NF L 05223, -FILETAGE 4 H -TARAUDAGE 5 H

FINITION: -ETAT DE SURFACE Ra, -CASSER TOUT ANGLE VIF, -CONGES D'OUTILS NON COTES

REVISIONS: MAILET C. (08/02/2013), GARCIN E. (08/02/2013)

EDUCHE: 1/5, TITRE: SVM PZ PANEL, SE3 LRR MOUNTING

NUMERO DE DOCUMENT: SE3LR100E10A, TYPE: 040, Ed.: 00, Rev.: -

ThalesAlenia Space logo

CE PLAN EST UNE COPIE CATIA VS ET NE PEUT ETRE MODIFIE