

1989 STATION REPORT AND ESTIMATE OF SYSTEMATIC ERRORS
ZIMMERWALD SATELLITE OBSERVATION STATION

P. Klöckler, T. Schildknecht
W. Gurtner, E. Pop,

Astronomical Institute
University of Berne
Sidlerstrasse 5
CH - 3012 Berne
Switzerland

Telephone: +41 31/65 85 91
Telex: 912 643 pibe ch
Telefax: +41 31/65 37 65
Mark-3/QUICK-COM: AIUB

LASER

Resonator

The original cavity by QUANTEL was passively mode-locked; the unavoidable statistical fluctuations inherent in this principle yielding a certain rate of misfirings and energy fluctuations. (30 % and ± 10 % approx.).

This not very satisfactory situation led to the installation of an acousto-optical mode-locker (INTRA ACTION ML-57B) and the appropriate adjustment of the cavity length. The results of the now active-passive modelocked oscillator cavity have much improved. We achieve an energy stability of ± 1 % and a pulse rate very near 100 %. Quite remarkable also is the reduction of the threshold voltage by 1 kilovolt.

The original dye cell (MS 400) also was replaced by the more recent design (MS 500), employing dye circulation and -filtering. We find it mechanically more stable and are glad to have longer standing times of the dye.

Pulse Selector

The Krytron-operated pulse selector caused much trouble and was replaced by the more recent SPS 411 model with avalanche transistor cascade switch. The optical part of the former, however, has been retained without much modification. The amplitude stability after the pulse selector thus was improved from ± 25 % to ± 3 %.

Second Harmonic Generator

Destruction of KD*P crystals has caused us much concern. A solution to that problem was found when the one crystal by INRAD was cut in two pieces (12 x 12 x 12 mm), polished, AR-coated and finally dry mounted.

Capacitor Banks

Radio interference problems from laser firing was a problem right from beginning. We tried to tackle it by grounding and screening of the offenders. Some interference still remained, and it was decided to buy new capacitor banks operated in simmering mode. This solved the problem entirely, and the lifetime of the flashlamps was greatly increased.

Optical Table

Substitution of the old stone bench by a honeycomb structured table by NRC improved mechanical stability and ease of adjustment. An enclosure was added to keep out dust. (Figs.1 and 2)

Present and Future Improvements

The laser delivers now up to 40 mJ safely; however, we would like to go beyond that. The beam profile still shows ripple which makes it unsafe to increase the present beam energy without spatial filtering. Such filters were built and tested, but we lost too much energy in them. For the near future we want to try out multipass-configurations - to afford more gain - and employ spatial filtering along with image relaying. The condition for such a laser configuration - a clean input beam profile - will hopefully be achieved by using apodised apertures, which we are presently trying to manufacture.

RANGING HARDWARE

Optics and Mount

Transmit and receive optics remained unchanged, except for the addition of two baffles in the receive optics. The low light level TV camera had to be replaced by the latest model of the same manufacturer, JAI of Denmark.

The angle encoders by HEIDENHAIN which were installed shortly after the 1986 workshop proved very reliable and sufficiently accurate.

Electronics

The main parts of the ranging electronics have not been changed since 1986. Some efforts were taken to ease the operator's task by bringing computer control to mains switching, automatic readout of meteo data and time comparisons. Many of the routine test functions now can be remotely accessed via modem and thus be speedily performed.

Epoch Timing

Our main concern was the failure of the LORAN-C receiver which made epoch corrections depend completely on television comparison with the federal bureau of standards (OFMET). An automatic time comparison system named TICOMT was designed and put into service at our station and OFMET. Since then, "a posteriori" station timing with one week's delay is performed automatically with an hourly uncertainty of less than 100 ns. (Figs. 3 and 4). This leaves the problem of the immediate timing for quick-look data, which was solved for the time being with a borrowed cesium standard. (starting October 10, 1988). Epoch timing presently is under consideration. A geodetic GPS receiver with timing option has been proposed for that purpose.

Improvements Planned or in Progress

Two main goals have been defined as most important: improvement of single shot rms noise to better than 2 cm and daytime tracking.

The modification of our photomultiplier package towards micro-channel plate technology will follow the standard set by the MOBLAS stations. However, the MCP biasing and gating circuits will be of our own design (Fig. 5). We also will mount the tube in the original holder by ITT to make it fit our existing tube housing.

Daytime tracking capability will require some redesign of our receive optics. Our present design focuses the telescope's aperture onto the photomultiplier's photocathode. Three intermediate lenses are used to achieve this and at the same time to have a stretch of relatively parallel light for the line filter (presently in use: 10 Å). Our 3 Å filter by Daystar will be tried again, which we have not used lately because of its relatively bad transmission (below 25 %) and also because of grease evaporation and deposit on the optical surface. A pinhole aperture should be introduced somewhere for reduction of the field of view from the present 10 mins. of arc (3 mrad) to a smaller value consistent with laser beam pointing precision (Fig. 6).

Efforts are presently taken to improve pointing by modelling flexure of the mount and correcting it by beam steering. We recently have built an X-Y drive for motion of the transmitting telescope front lens. This approach has yet to be implemented and verified.

STATION COMPUTER

In 1977, the AIUB purchased a PDP 11/40 minicomputer to be used as station computer at the SLR observatory for the following purposes:
- pass preparation - control of the satellite tracking - data collection - data screening, storage, and exchange.

Additionally the computer has been extensively used in astronomical applications such as orbit intergration of planets, minor planets and comets.

Increasing difficulties with hardware maintenance, limitations in computing speed and memory size, and future tasks under discussion at AIUB led to the decision to replace the PDP 11/40 with a more powerful computer in 1987.

The evaluation of the new system lead to the purchase of a VAXstation II with the following configuration:

11 MB memory, VR260 monitor, mouse, and TK50 tape unit. Enhancements include a CDC Wren III 150 MB disk and a 9-track magnetic tape drive, as well as asynchronous interfaces and a modem. The software includes microVMS V4.5 operating system, VWS workstation software V3.0, VAX Fortran V4.0, VAX GKS V2.0 graphical kernel system, and Kinetics System CAMAC driver.

Most of the software that has been developed on the PDP 11/40 under RT-11 could be easily transformed onto the VAXstation without major changes. Special care had to be taken on system-dependent problem solutions, e.g.

- special keyboard input routines (RT-11: System calls; VMS: QIO function calls)
- serial interface input/output routines: (RT-11: straight-forward approach by addressing control and data registers of the interfaces; VMS: QIO function calls).

The CAMAC interface system driver provided by Kinetics System proved to be too slow for the data transfer between the VAX and the individual CAMAC interfaces. A direct approach accessing the control and data registers of the CAMAC bus adapter has therefore been chosen. These registers in the VAX I/O page are mapped into a Fortran named COMMON block, so they can be written or read using simple arithmetic assignment statements. This approach however only works if the CAMAC system is never used by more than one user at a time, since the access control provided by the CAMAC driver is bypassed. The Kinetics System CAMAC driver routines handling interrupts have proved to be very valuable.

The transformations of the most important modules of the existing software and some new developments have been carried out in about 3 months by 3 members of the institute's staff. The actual change from the PDP to the VAX was done between two satellite passes of the same night.

(For more information see SLR Newsletter, Vol. 2, No. 1, October 1987).

OPERATION

Routine Operation

The operational procedures have been simplified and automatized so that the station is routinely operated by one staff member at a time only. Since 1988 three students have been included into the observer team, each one having been assigned to one night per week. Together with the institute's staff a 7 night per week coverage can be achieved.

For the numbers of passes and returns see Figs. 7 and 8. Clearly visible is the break in winter '87/88, when the laser was rebuilt.

Calibrations

This summary report covers the period from May 15, 1989 through October 1, 1989. The summary valid up to May '89 has been published in the proceedings of the sixth LRS workshop, Vol. I, p. 123. The present error budget will stay valid until the microchannel receiver package will be put into service.

Modelling and Environmental Errors

Meteorological measurements are now fully automatic with a 30 min. readout interval. The pressure sensor has been calibrated at OFMET

primary standard to be within $\pm .1$ mbar; humidity can be calibrated with test liquids to $\pm 2\%$ and temperature is better than $\pm .5$ K. We allow for a .5 mbar drift until the next calibration.

Spatial Variation

No test has been made due to lack of external calibration. Since our laser is up to the MOBILAS standard, we feel it save to allow for double the value as evaluated by others. (MOBLAS 7, February 29, 1988).

Temporal Variation

As we perform in-pass calibration, temporal effects are minimized. However, the calibration measurements are averaged over the whole pass; thus, half of the found temporal variation over one hour is being allowed for (Fig. 9).

Amplitude Dependence

The amplitudes of all received pulses are registered via a CAMAC charge digitizer Module (LE CROY 2249). Studies of the amplitude dependence lead to improved adjustments of the constant fraction discriminator (ORTEC 934). There are, however, remaining systematics (Fig. 10) The latter are modelled using a large amount of online or offline calibration data to create a look-up correction table. Until now the model consists of a simple linear fit. Fig. 11 shows the same data as Fig. 10 but amplitude corrected with our standard model used throughout since October 1987. There seems to be no more signal beyond the noise level.

We wish to point out that the original range data in our data base remains unchanged enabling us to adjust and test new models with a large amount of existing observations.

Special efforts to improve the modelling will be taken during the implementation phase of the planned new receiver package (Micro-channel PMT, TENNELEC 454 CFD).

Calibration Path (Survey)

The uncertainty is due to a piece of optical fibre, the optical length of which has to be determined by a time delay measurement using the attenuated laser pulse. This method guarantees an accuracy of 100 picoseconds.

Calibration Path (Meteorological Conditions)

Not applicable because of internal calibration.

Mount Model

Mount eccentricity is removed by internal calibration.

Timing Errors

Hourly TV comparisons with UTC(OFM) ensure an accuracy of 100 ns for full rate data. QL data are tagged with 5 microseconds worst case.

Unmodelled but Systematic Effects

Looking at histograms of calibration measurements, or at histograms of residuals of satellite range observations (after screening and orbit improvement), reveals still some systematics (Fig. 12). We attribute most of this remaining signal to our photomultiplier and/or constant-fraction- discriminator and hope to improve the situation by implementing the new receiver package.

Software Tools

A software package to analyze correlations between all acquired online and offline data was recently installed. The program may also be used to estimate and test time walk models (see above). This sort of tools will gain importance in future, specially in connection with improved single shot rms and during hardware upgrades. The figures in this chapter were produced with the help of this utility.

The estimated systematic errors of Zimmerwald LRS for the reported period are summarized in Table 1.



CABINET: OPERATING STATE

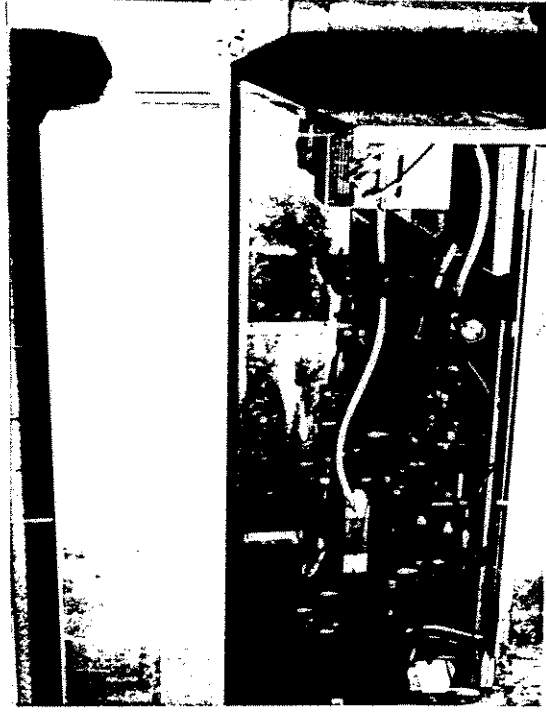

CABINET: SERVICE STATE

FIGURE 1:

THE NEW ZIMMERWALD LASER OVERALL VIEW

A.I.U.B. 1989

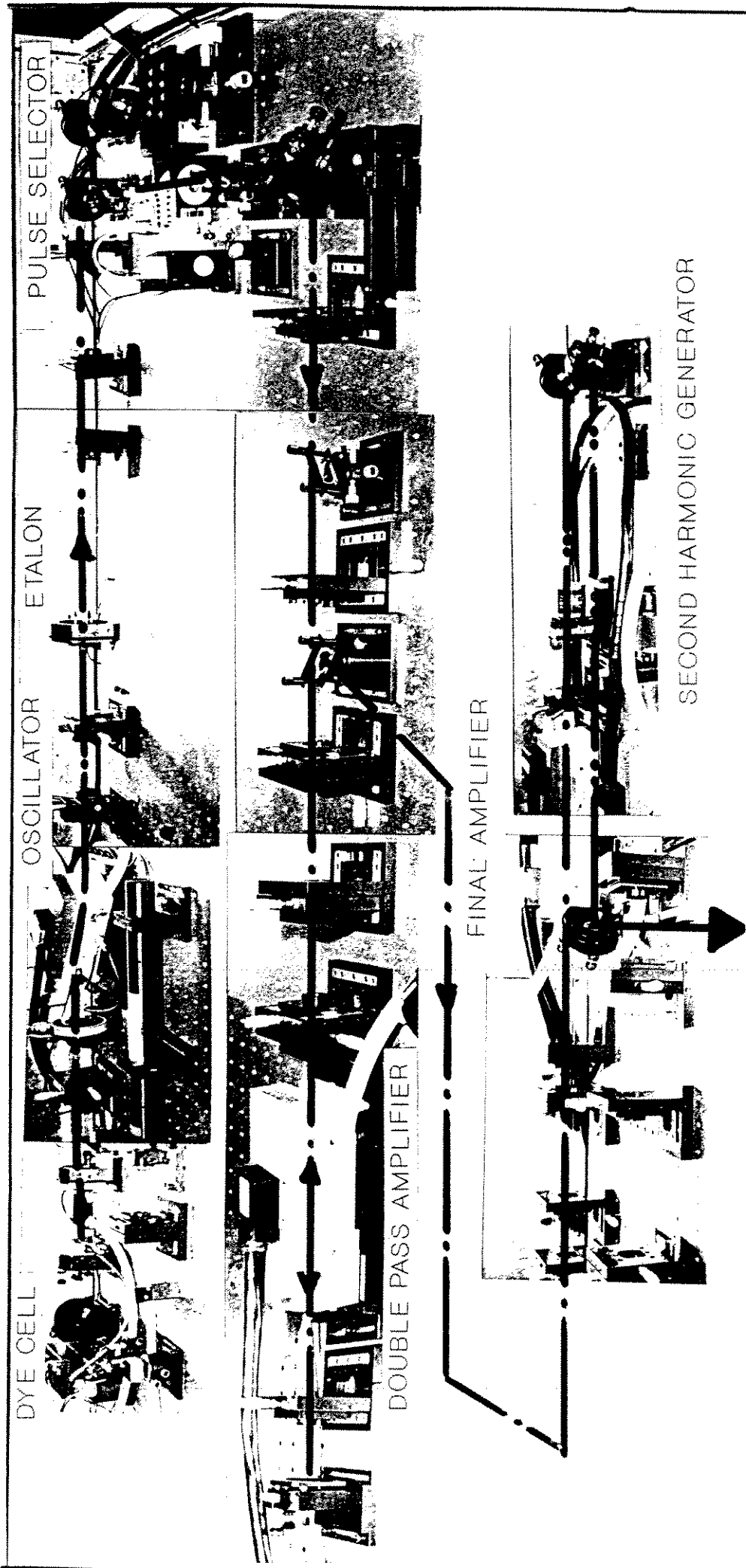
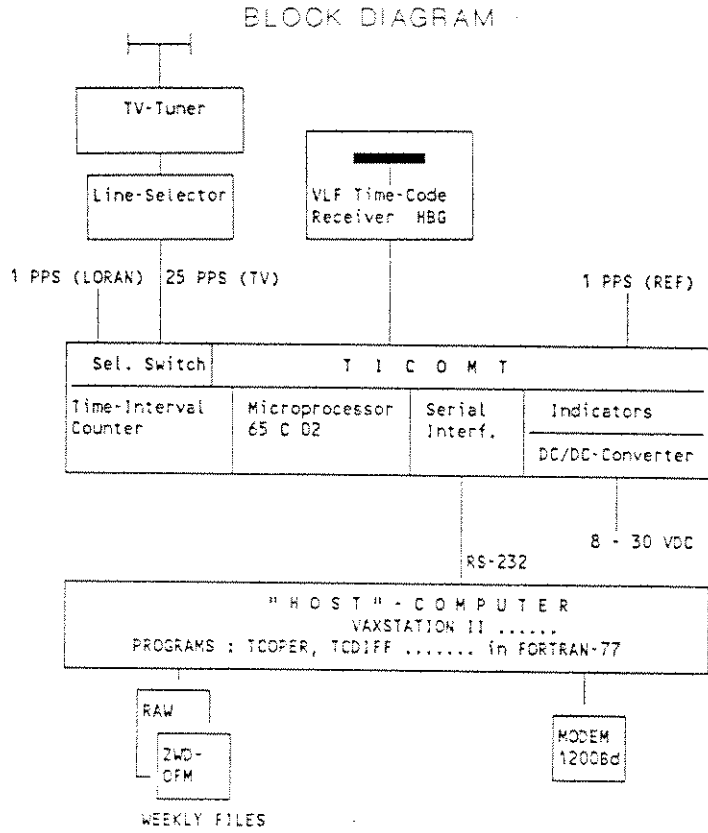

FIGURE 2:

THE NEW ZIMMERWALD LASER
 DEPICTION OF THE THREE OPTICAL LINES
 A.I.U.B. 1989

Fig.3
TICOMT (Time Comparison by Television)



VIEW OF TICOMT UNIT

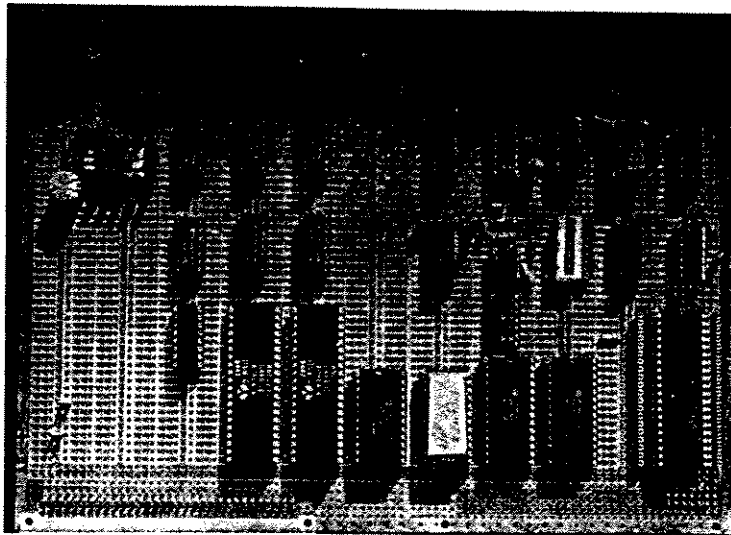

Zimmerwald SLR

Figure 6: Relative Intensity of a Large Star as seen by the Photomultiplier
as compared with pointing error ellipse

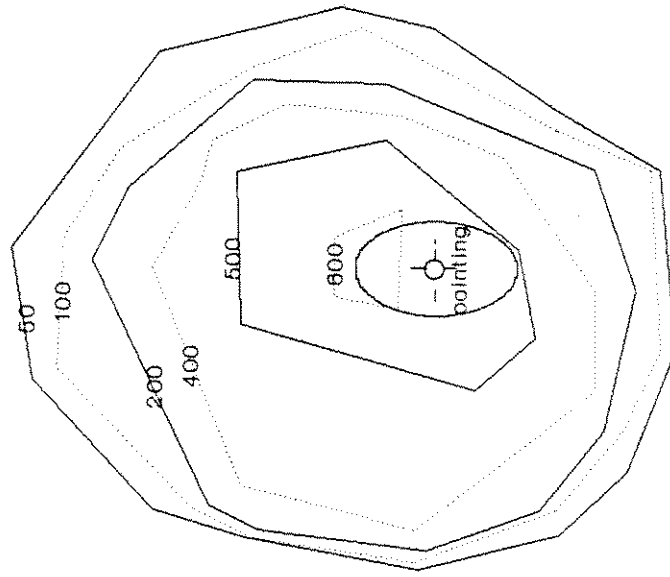

1 arcmin. approx.

ZIMMERWALD SLR

FIG. 4
TELEVISION TIME TRANSFER

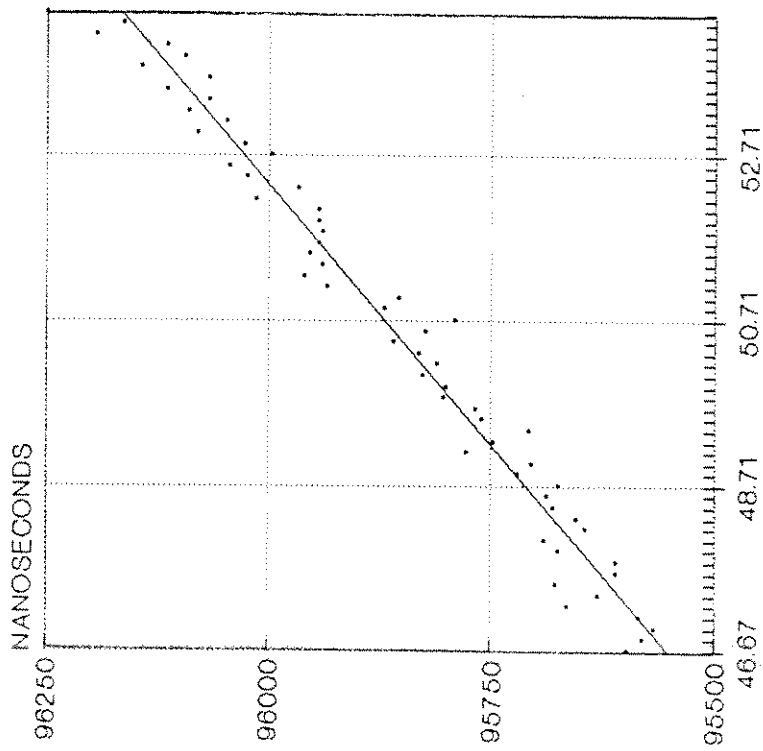

MJD - 47400

ZWD - UTC(OFM)

ZIMMERWALD SLR

Figure 5 MCP Photomultiplier Receiver Diagram

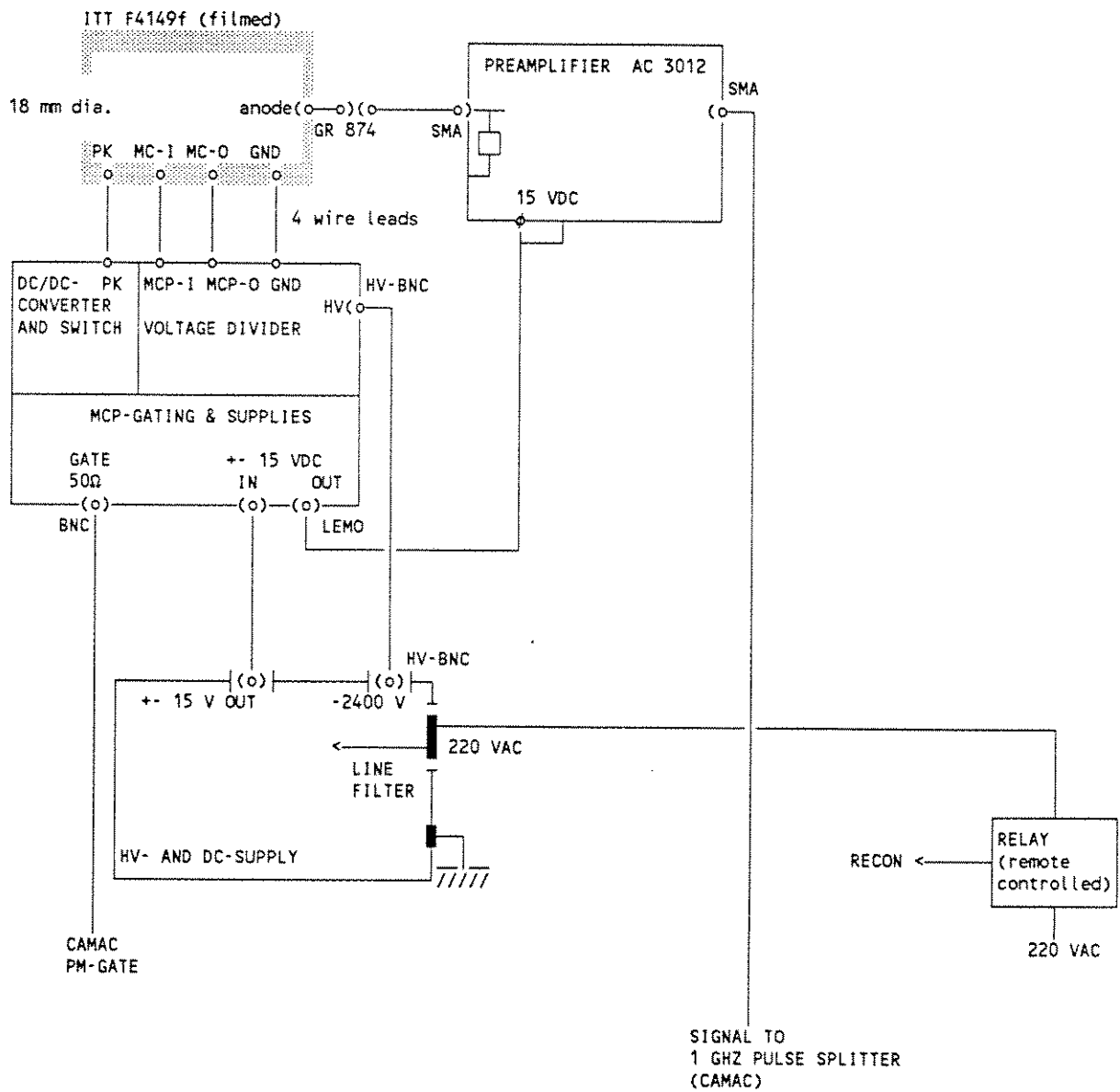

Zimmerwald SLR

Zimmerwald SLR Observatory Passes per Month

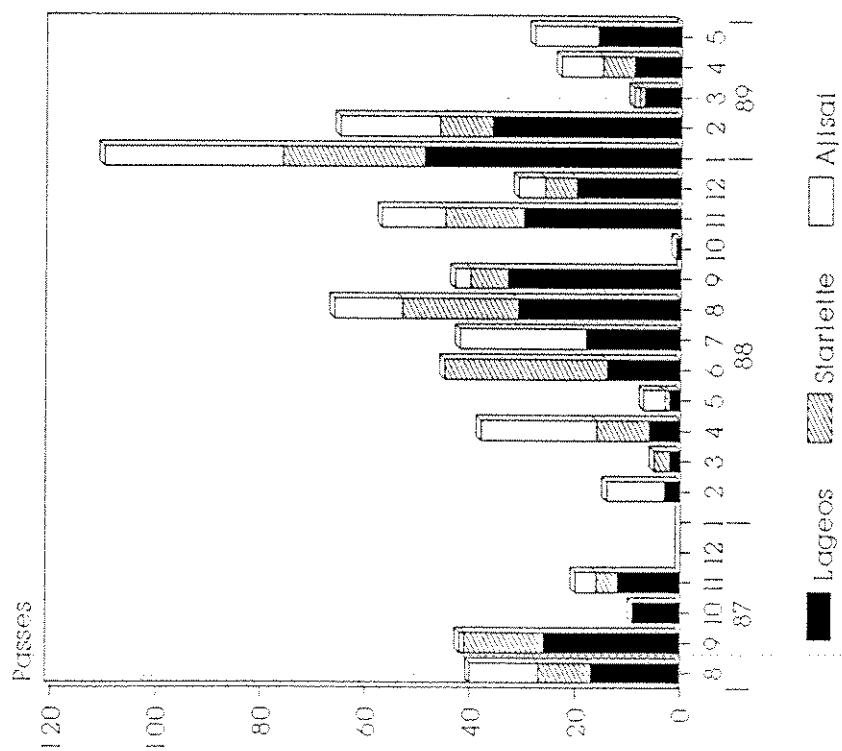

Figure 7

Zimmerwald SLR Observatory Number of Observations per Month

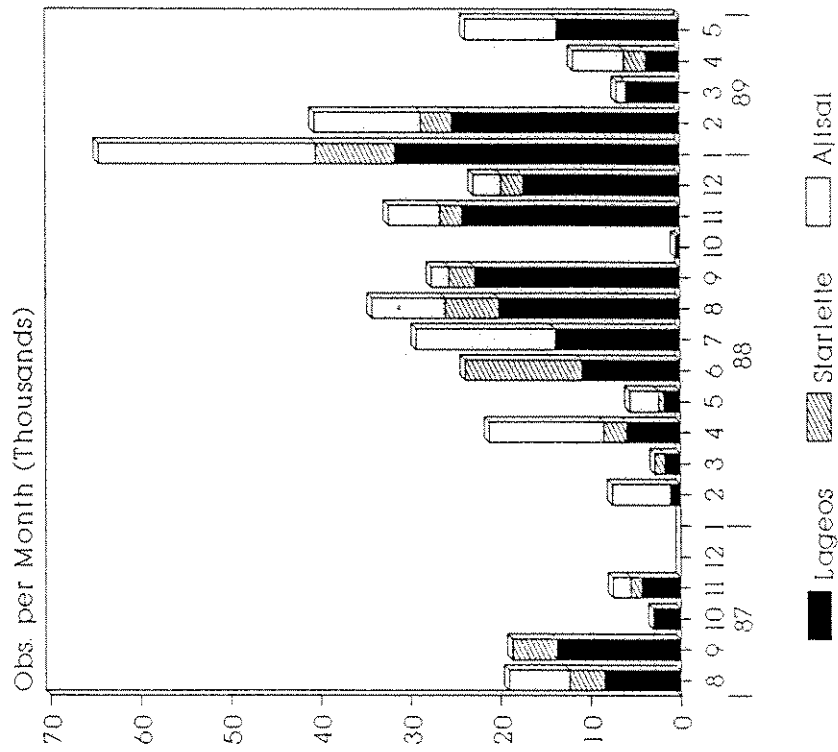
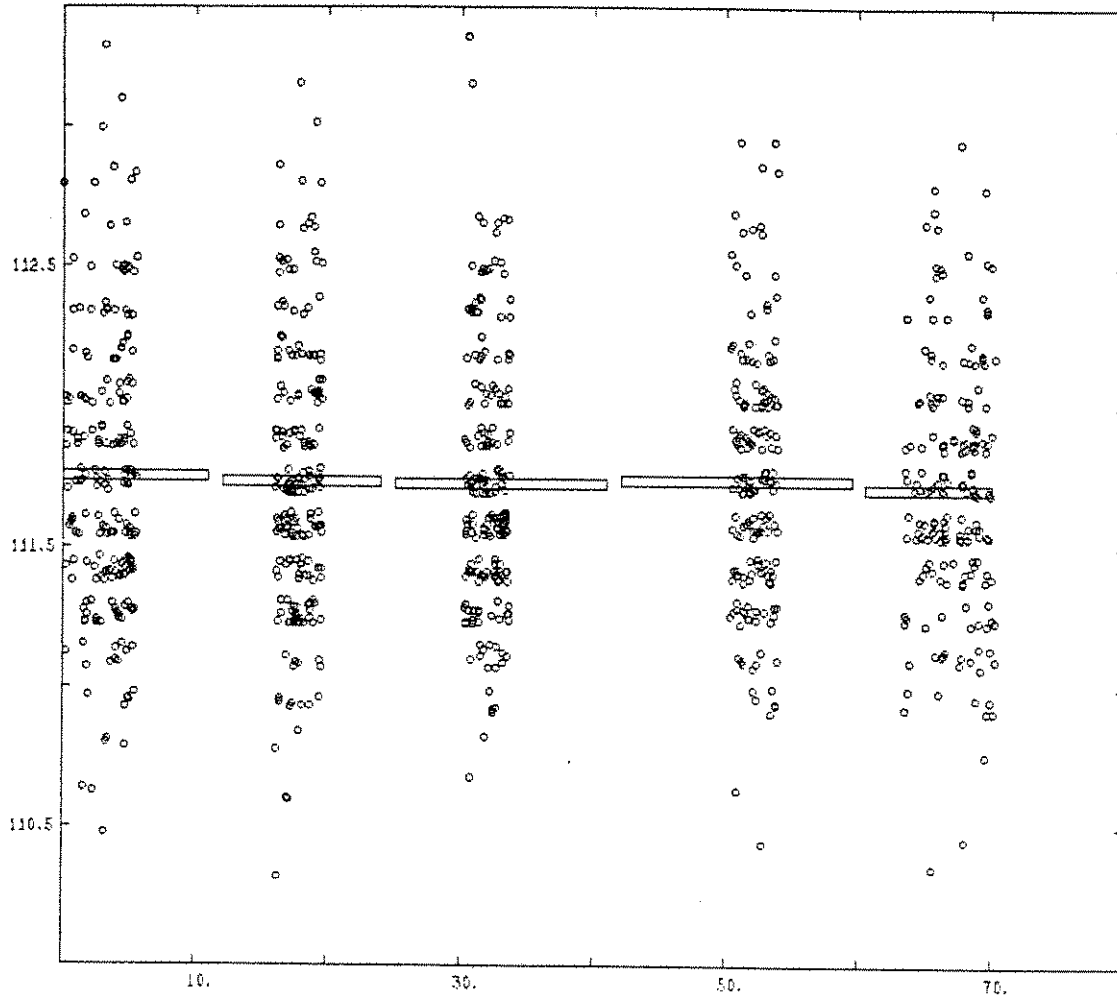

Figure 8

Figure 9 Temporal Variations

Calibration [ns] vs. Time [min]



BOX	# OBS	MEAN X	MEAN Y	RMS MEAN	RMS OBS
1	205	3.43	111.750 ns	.0356 ns	.511 ns
2	198	17.77	111.734 ns	.0346 ns	.488 ns
3	194	31.96	111.726 ns	.0332 ns	.463 ns
4	170	52.16	111.737 ns	.0345 ns	.451 ns
5	182	66.97	111.709 ns	.0328 ns	.443 ns

Zimmerwald SLR

Figure 10 Amplitude Dependence (Uncorrected)

Calibrations [ns] vs. Stop ADC [cnts]

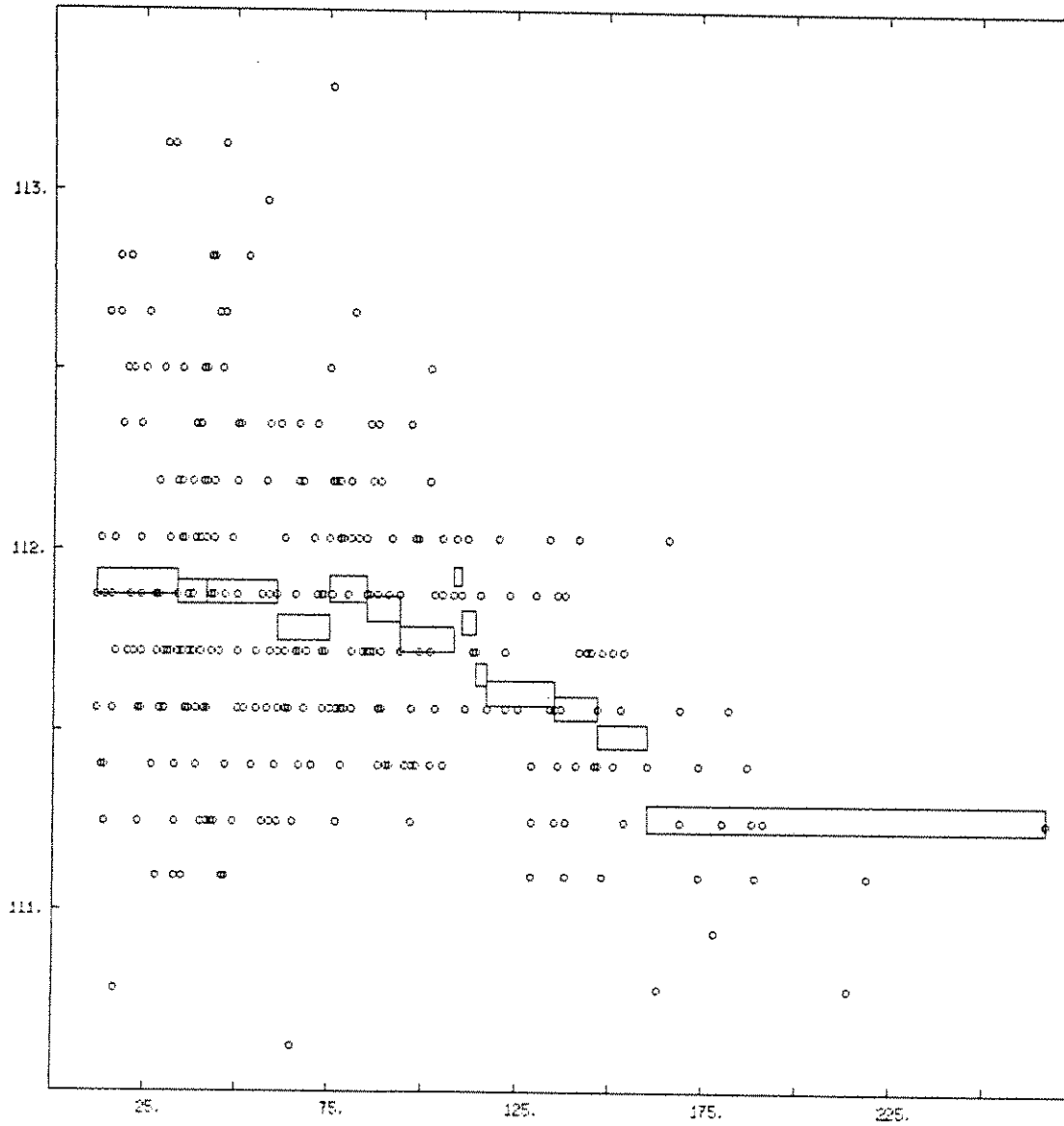

box heights indicate
rms of the mean
represented by boxes
Zimmerwald SLR

Figure 11 Amplitude Dependence (Corrected)

Calibrations [ns] vs. Stop ADC [cnts]

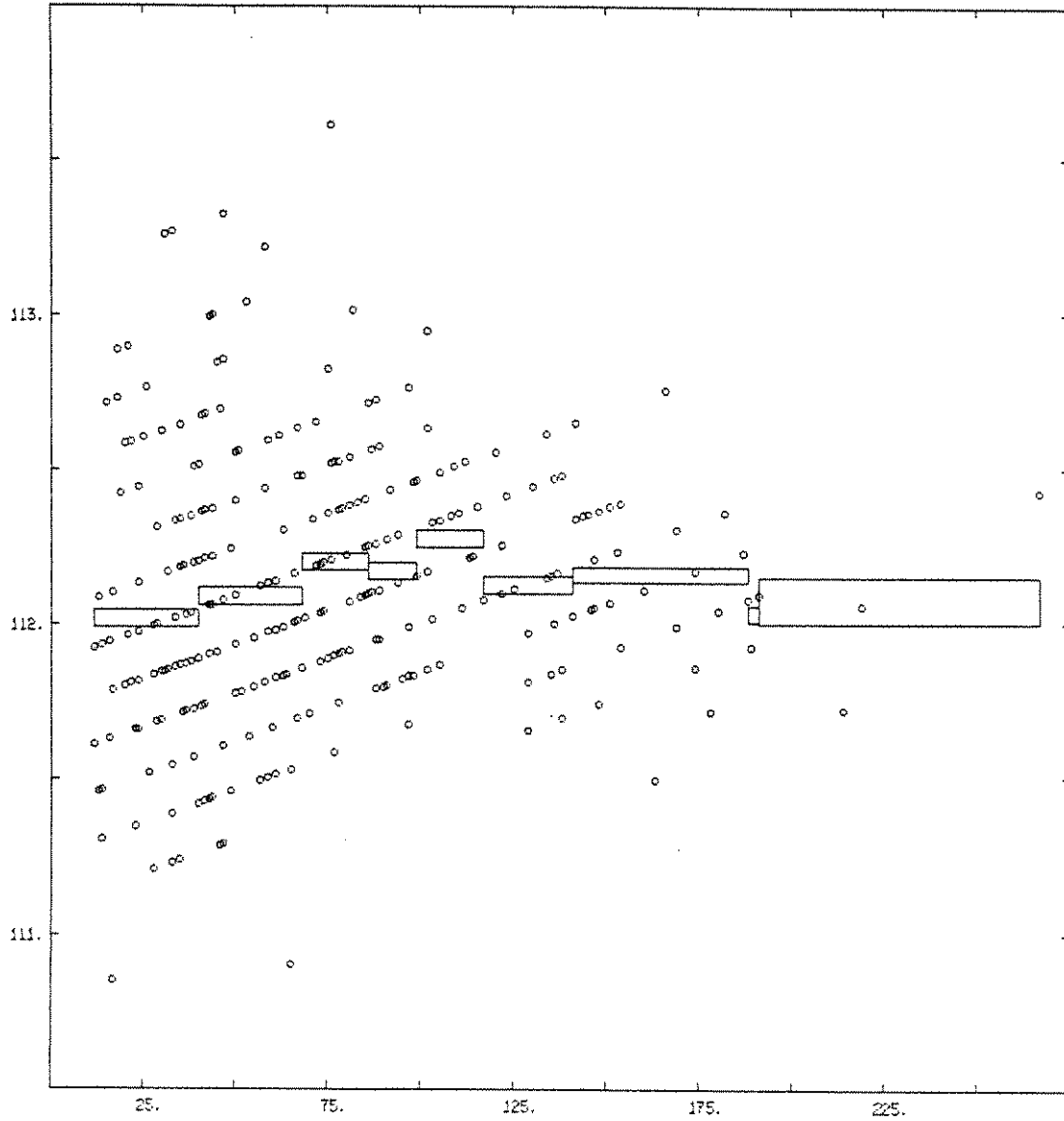

box heights indicate
rms of the mean
represented by boxes
Zimmerwald SLR

Figure 12 Histogramm of Residuals

Histogram of Residuals [ns]

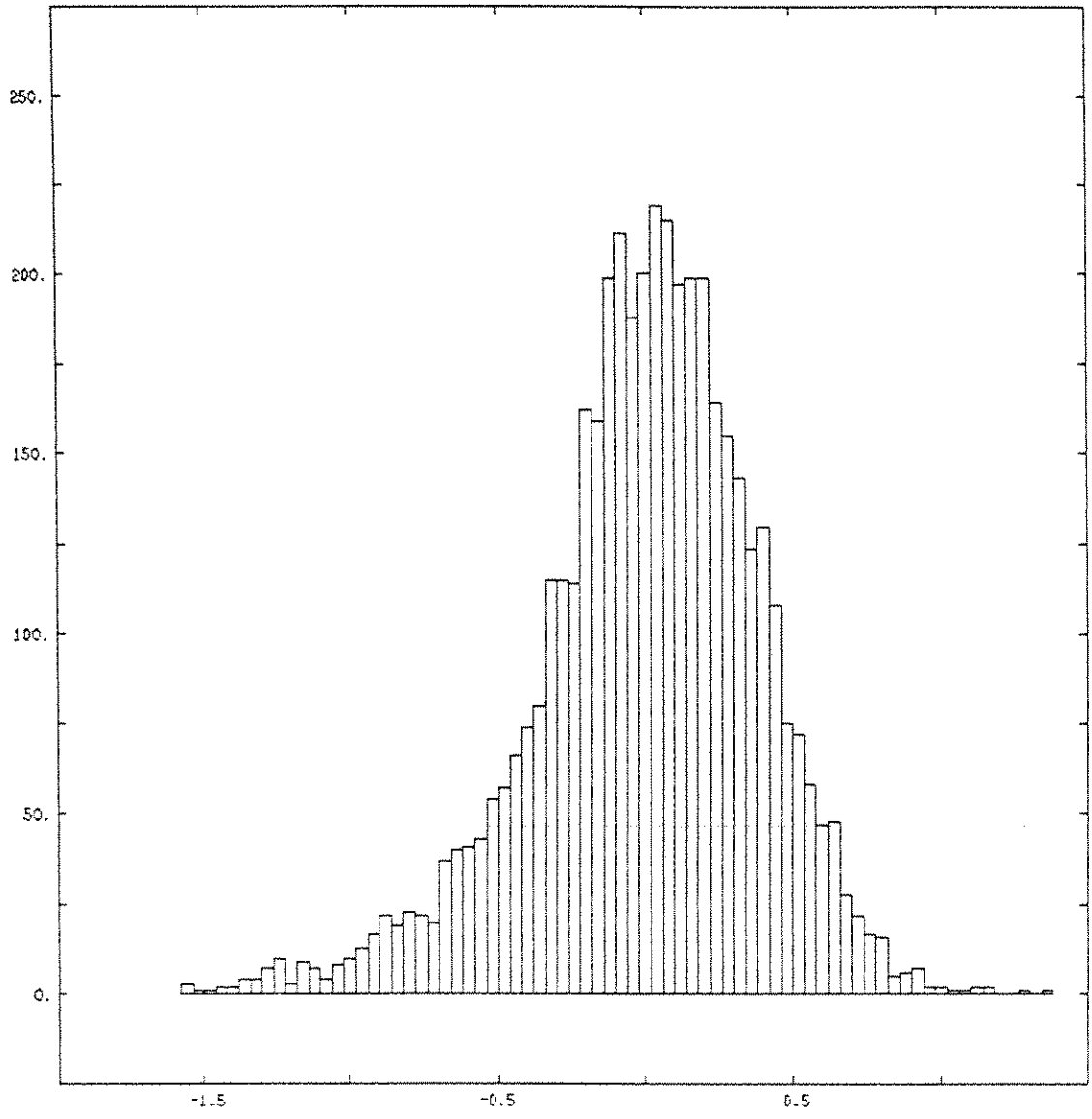

Residuals of 10

Lageos Passes

Zimmerwald SLR

Table 1
Estimate of Systematic Ranging Errors

RANGING ERRORS (CM)

	PASS	DAY	MONTH	INDEF.
MODELLING ENVIRONMENTAL ERRORS				
ATMOSPHERIC PROPAGATION (MODEL)	.5	.5	.5	.5
ATMOSPHERIC PROPAGATION (METEOROLOGICAL MEASUREMENTS)	.25	.25	.25	.25
SPACECRAFT CENTER OF MASS	.2	.2	.2	.2
GROUND SURVEY OF LASER POSITION	-	-	-	-
DATA AGGREGATION	-	-	-	-
R.S.S.	.6	.6	.6	.6
RANGING MACHINE ERRORS				
SPATIAL VARIATION	.6	-	-	-
TEMPORAL VARIATION	.2	.2	.2	.2
SIGNAL STRENGTH VARIATION <i>half of 20 ps</i> <i>100 ps \leq 50 cts.</i>	1.5	1.5	1.5	1.5
CALIBRATION PATH (SURVEY)	1.5	1.5	1.5	1.5
CALIBRATION PATH (METEOROLOGICAL CONDITIONS)	-	-	-	-
MOUNT ECCENTRICITIES	.1	.1	.1	.1
R.S.S.	2.2	2.1	2.1	2.1

TIMING ERRORS (MICROSEC)

PORTABLE CLOCK SET	.1	.1	.1	.1
BROADCAST MONITORING	5. *	5. *	.1	.1
R.S.S.	5	5	.15	.15

* for QL data only

Zimmerwald SLR - May, 1, 1989 ...

LASER STATION GRAZ

MAIN ACTIVITIES AND RESULTS OF THE LAST TWO YEARS

Contact: Georg KIRCHNER
SLR Station Graz
Observatory Lustbühel
Lustbühelstrasse 46
A-8042 GRAZ, AUSTRIA
Tel.: (0)316-42231; Telex: 311078 obslg a
MarkIII: grazlas

Abstract

During 1988 and 1989 the activities in Graz concentrated mainly on 3 major topics:

- Replacing the PMT with an MCP with low voltage gating: After some adjustment work the RMS jitter was improved to better than ± 2 cm;
- Testing and optimizing a single-photon avalanche diode (SPAD), developed by the Prague group, for ranging to all geodetic satellites, including ETALON 1+2; the RMS jitter again could be improved, and is now better than ± 1.5 cm for routine operation.
- Participation in the LASSO experiment: During September and October 1989 we obtained returns from METEOSAT P2 and also datations on board of the satellite.

In addition we tried to observe as many passes as possible, inspite of sometimes severe financial problems.

1. Microchannel Plate Operation

In June 1988 our old, conventional PMT (RCA 8852) was replaced with a two-stage, gated MCP-PMT (Hamamatsu R2024U-01). The main features of this tube are:

- Two-stage construction; needs additional 13-dB amplifier;
- Low voltage gating (12 V);
- Quantum Efficiency 10 %;
- Pulse rise time 270 ps.

An additional MCP-shutter (fig. 1) opens only for a few milliseconds around the expected returns, keeping off any backscatter and minimizing average anode current. The inverter between MCP and amplifier supplies positive pulses for the - inverting - amplifier; the TC454 CF discriminator is gated with the same - little bit delayed - pulse as the MCP. The MCP itself contains an additional mesh after the cathode, allowing convenient small gating pulses of less than 15 V.

Range gate widths used with the MCP can be varied between 5 μ s (limited by the MCP's internal gating circuit) and 10 ns (limited by the electronics).

The MCP improved the overall RMS of the Graz SLR station to better than ± 2 cm (fig. 2) for LAGEOS, STARLETTE and AJISAI.

Up to now we did not experience MCP lifetime problems.

2. The Prague SPAD Detector

In March 1989, the MCP was replaced by the Single Photon Avalanche Detector Package (SPAD), which was developed and built in Prague. The main features of this package are:

- 100 μ m active area of the diode;
- Operation without cooling at temperatures up to 28°C;
- Small bias voltage (about 30 V only);
- TTL level gate voltage;
- High quantum efficiency (20 %);
- High output signal (NIM level); no amplifier needed;
- No external discriminator needed;
- Very high stability;
- No lifetime problems.

All passes since March 1989 up to now have been measured with the SPAD; the overall RMS jitter of the SLR station Graz is now better than 1.5 cm (fig. 2).

One of the challenges of the SPAD is the focussing and aligning of the received photons to the 100 μm SPAD area. In Graz the Nd:YAG oscillator was used for a rough pre-alignment; for fine alignment, a bright star was moved within the field-of-view, measuring the SPAD noise (i.e. the mean time from gate start to the first break). For routine alignment, also a HeNe laser is used.

The first pass measured with the SPAD, short after finishing the alignment, was a LAGEOS pass (Fig. 3), showing a high return rate (the laser rep. rate is 2.5 Hz only).

Using the very accurate predictions of the University of Texas (IRV's) it is also no problem to range to ETALON-1 and ETALON-2 with the SPAD; fig. 4 shows the residuals of 1 hour of ranging to ETALON-1, indicating again the good return rate and showing also the - acceptable - noise connected with the SPAD.

Fig. 5 shows the dependence of noise and jitter from the SPAD voltage above break.

3. The LASSO experiment: Results in Graz

The SLR station Graz has two laser systems; one is a Nd:YAG laser (100 mJ/532 nm, 10 Hz, 100 ps) for ranging with high accuracy to geodetic satellites; the second is a Ruby laser with 6 ns / 4 J / 4 s (or 3 ns / 2.5 J / 4s), dedicated for the LASSO experiment.

During the tests for the LASSO experiment in the SLR station Graz a number of problems (fig. 6) delayed the first results until end of August 89:

- Need of an additional dichroic mirror for visual observation of METEOSAT during ranging, because the pointing predictions were not accurate enough for blind tracking;
- Wrong spin phase predictions for the LASSO satellite during winter 1988/89;
- A disc head crash at beginning of 1989;
- Damage of the ruby amplifier rod; repolishing was done by the Prague SLR group - many thanks to you !
- Unusual bad weather periods during July and August 89; nevertheless some tests were performed using ETALON-1 as a convenient test target; overall performance of the Ruby ranging system was checked and optimized.
- Still incorrect predictions of METEOSAT's rotational phase (table 1), making ranging with low repetition rates somewhat difficult.

To overcome the phase prediction problem, the software was modified to allow for firing in stroboscopic mode (i.e.

using a repetition rate slightly higher than a multiple of the satellite rotation period) and/or to allow for changing the phase in real time (i.e. adjusting the firing times for random shift of the phase). This allowed also to use good weather on weekends with no phase predictions available.

During the first tests in Aug. 31/89 - using stroboscopic mode outside of the scheduled sessions - we obtained the first returns; since then we ranged a few times to Me-teosat, getting returns whenever the weather was good enough to see the satellite; during the last sessions in October 89 - short before the satellite started to move westwards - also datations were obtained on the satellite.

Table 1: List of LASSO observations

Date	Returns	Remarks
31.08.	9	No session; strobe mode: 1°/shot phase shift
01.09.	4	Same as above
16.09.	3	Weekend; Used to determine phase.
16.09.	9	Using this determined phase.
29.09.	42	1 h after session; phase offset 170°
29.09.	12	As above; phase offset stable at 170°
09.10.	9	During session; datations on sat.; phase 20°
10.10.	0	Datations during session;
10.10.	13	Datations during session; phase ≈ 20°
13.10.	8	session; possible datations; phase 50°
13.10.	25	session; poss. datations; phase stable at 50°

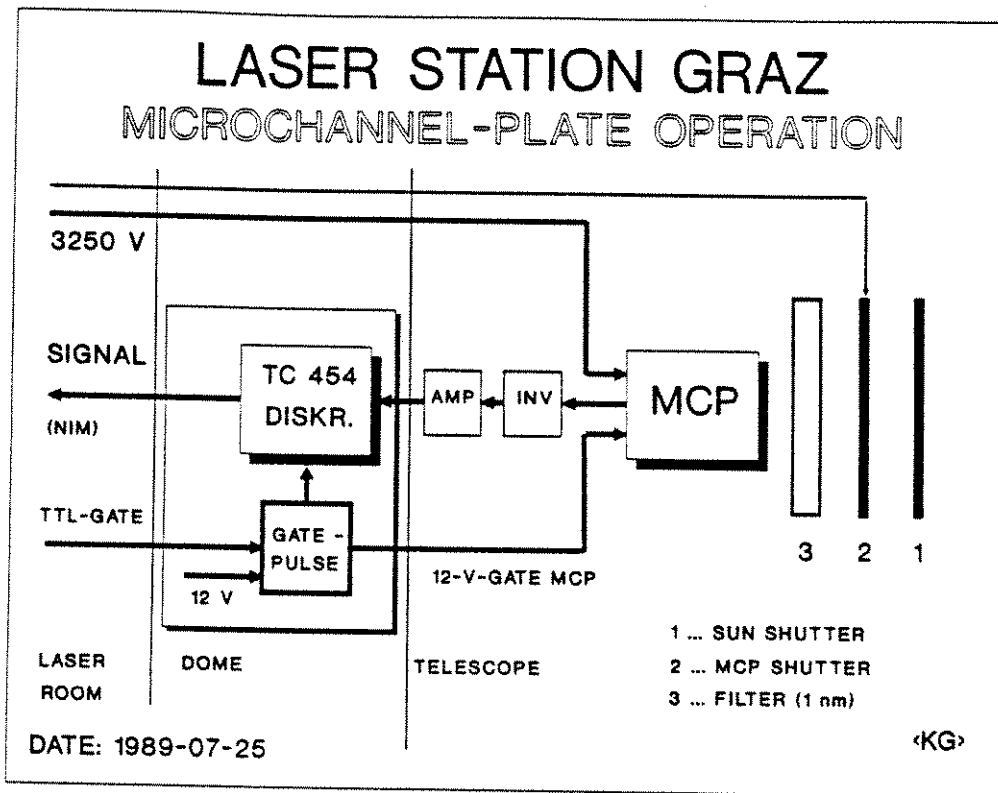

Fig. 1: Microchannel Plate Operation

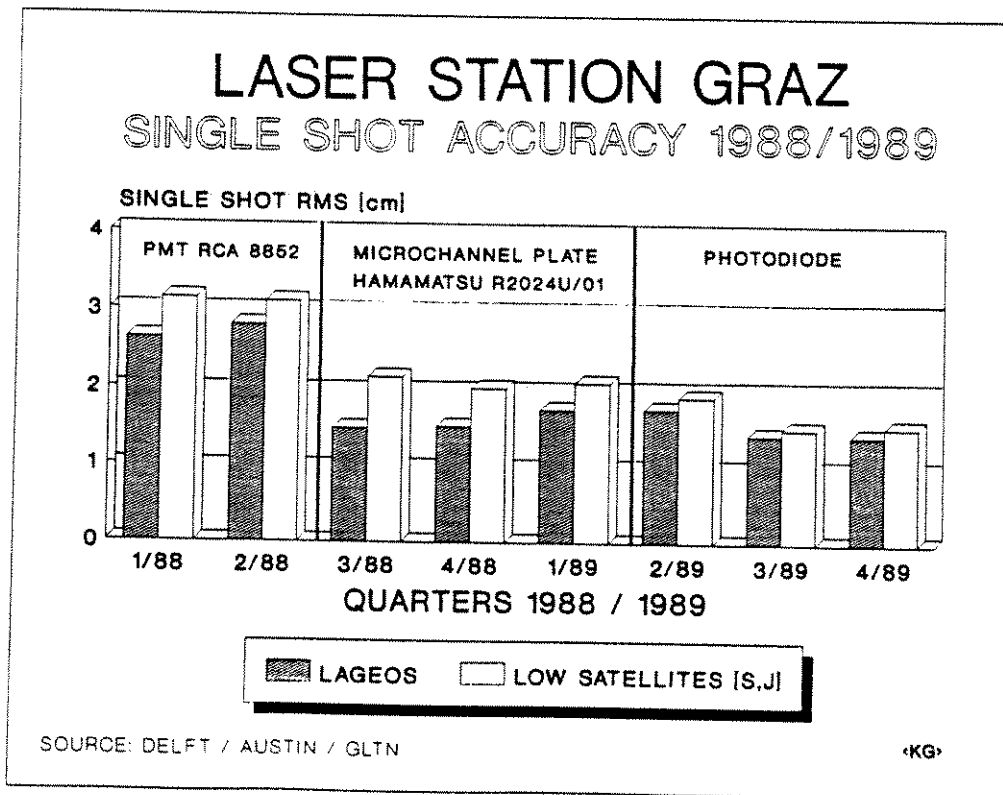

Fig. 2: Single Shot Accuracy

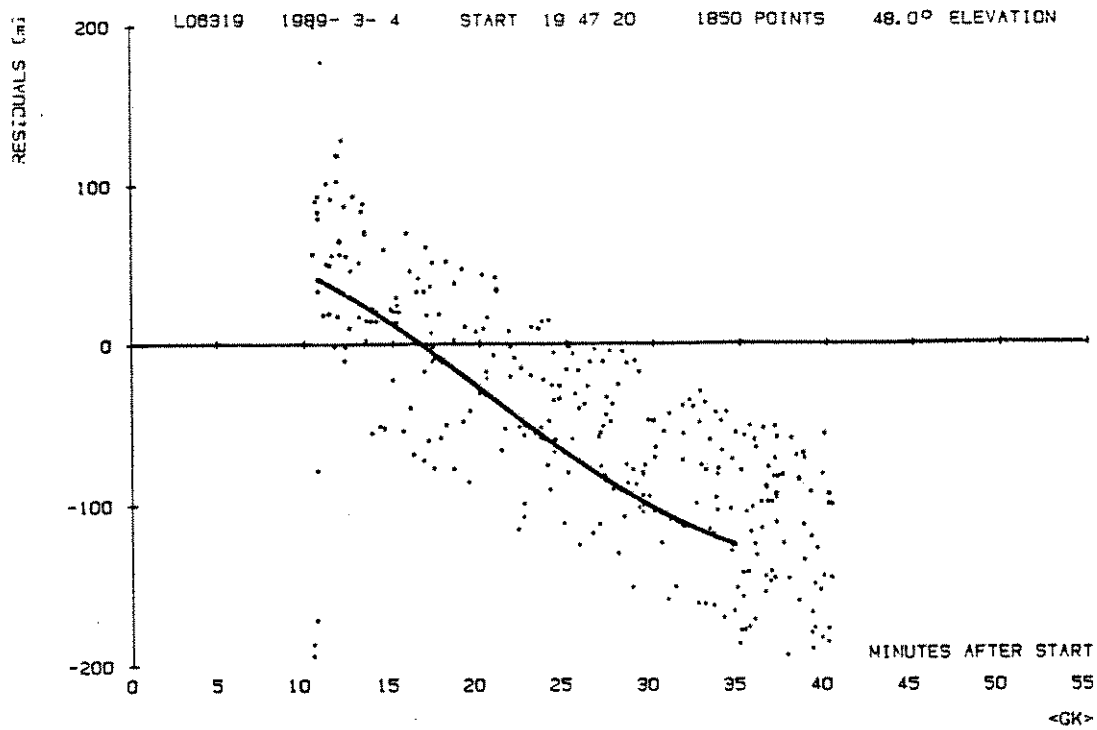

Fig. 3: First Pass with SPAD (LAGEOS)

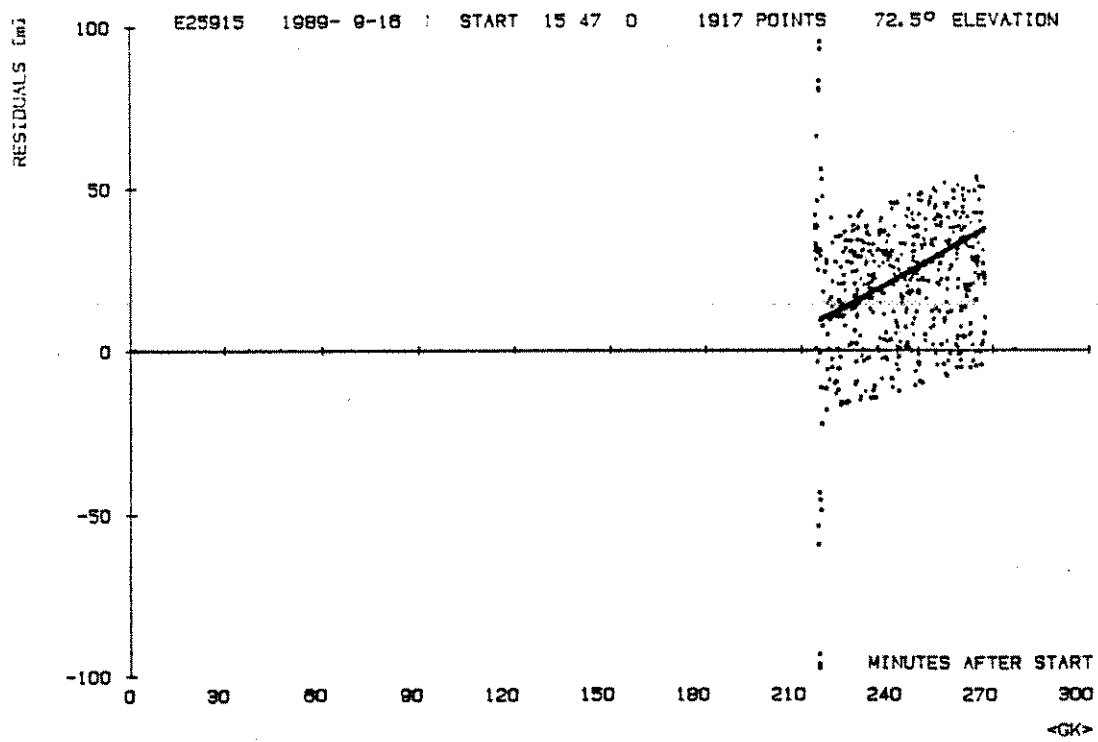
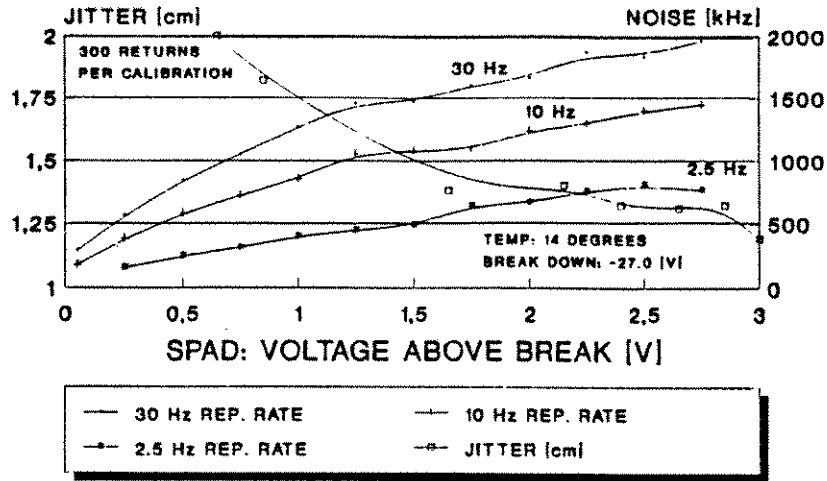

Fig. 4: ETALON-1; Measured With SPAD

LASER STATION GRAZ

JITTER/NOISE VS. VOLTS ABOVE BREAK



1989-09-26

<KG>

Fig. 5: SPAD Noise Measurements

LASER STATION GRAZ

LASSO SESSION STATISTICS

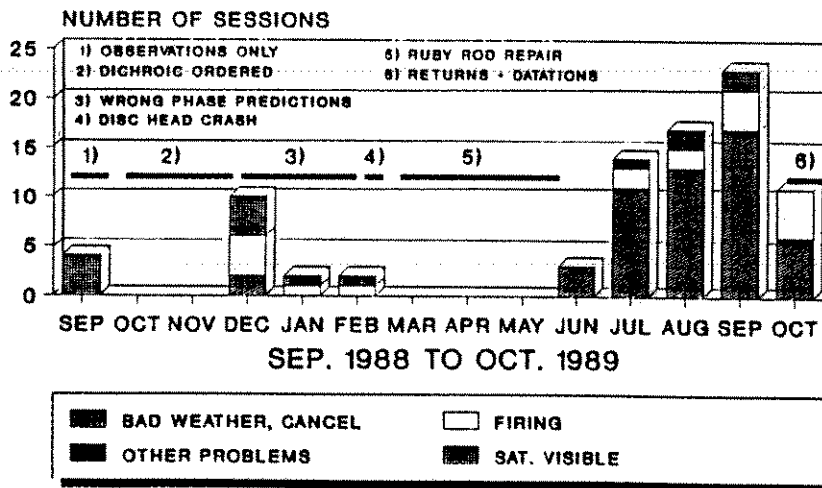

SEP. 89: 6 SESSIONS / 79 RETURNS

1989-10-26

OCT. 89: 6 SESSIONS / 56 RETURNS / DATATIONS IN 4 SESSIONS

<KG>

Fig. 6: LASSO Sessions



STATUS REPORT ON THE SATELLITE LASER RANGING SYSTEM AT WETTZELL

R. DASSING, W. HOPPE, W. MÜLLER,
W. SCHLÜTER, R. STÖGER
INSTITUT FÜR ANGEWANDTE GEODÄSIE

U. SCHREIBER
FORSCHUNGSEINRICHTUNG SATELLITENGEODÄSIE

FUNDAMENTALSTATION WETTZELL DER
FORSCHUNGSGRUPPE SATELLITENGEODÄSIE
D-8493 KÖTZTING

1. Status of the observations

The satellite laser ranging system at Wettzell has been in operation since 1976. During that time the system has provided observations to the satellites GEOS-3 (until 1981), Beacon-3 (until 1983), Seasat-1 (1978 only), LAGEOS (since 1976), Starlette (since 1976), Ajisai (since 1986) and Etalon-1 (since March 1989).

The system has only night-time tracking capability. This is mainly due to an instability in the detection optics. However, to avoid down time, daylight passes are no longer being attempted, as the Varian cross-field photo-multiplier is still in use and it is necessary to protect it from possible damage. Regular protective maintenance is performed on the Sylvania Nd:YAG laser, which is operated only at half power.

As the Sylvania laser ranging system (SRS) will be replaced by the Wettzell Laser Ranging System (WLRS) in the course of next months, no major modifications directed to achieving higher ranging accuracy or increased levels of automation are being planned for the old system.

Two engineers are still required to operate the system; man-power is available to operate the system on approx. 270 nights per year. Figure 1 summarises the number of observed passes taken over the last two years. With LAGEOS moving progressively to predominantly day-time passes during the first part of 1988 and in the period July to October 1989 few observations were made to this satellite during those periods.

The single shot precision of the system is estimated to be approx. ± 5 cm.

2. Investigations of local height variations at the station

A decrease in the height component of the site at Wettzell has been postulated by some data analysts on the basis of both SLR and VLBI results.

D. Smith et al /1989/ stated that "... vertical motion at Wettzell is statistically significant at the level of 3 to 4 mm/year ...".

Measurements have been made to monitor possible local movements since the SRS was put into operation. Local networks for the detection of horizontal and vertical motions have been established and extend some 30 km around the station. These networks were originally surveyed by classical techniques and have recently been re-observed using GPS. No local motions have been detected from results of these observations.

Typeset by $\Lambda\text{M}\text{S}\text{-T}\text{E}\text{X}$

A dense gravity network has also been set up in the vicinity of the station. The measurements have been repeated annually and no height changes are inferred by these observations either.

As systematic offsets in the ranges measured by SRS could also influence the height component of the station position this possibility has also been investigated. Two factors can systematically influence the ranges in this way:

- the calibration value estimated by ranging to a nearby terrestrial target;
- the received power correction applied to compensate the result for the variations of received signal strength coming from the terrestrial target and the satellite.

The distance to the calibration target could, for example, have changed in the course of time, due perhaps to instabilities in the target itself. A stronger return signal from the terrestrial target on the other hand results in a range which is too short.

Both of these effects have been checked. The distance from SRS to the terrestrial target has been re-measured and the received power correction has been controlled. No changes can be derived from either of these sources. Nevertheless, it is planned to continue these investigations to verify local effects.

3. Future plans for SRS

In the course of the next few months SRS will be replaced by WLRS. In order to maintain the level of observational accuracy without introducing systematic offsets, a period of parallel observations is being scheduled for the two systems following co-location.

The more distant future of SRS is still under consideration.

REFERENCES

- Smith, D., et al., *Mediterranean Geodynamics from Satellite Laser Ranging*, AGU-Spring Meeting, May 1989.

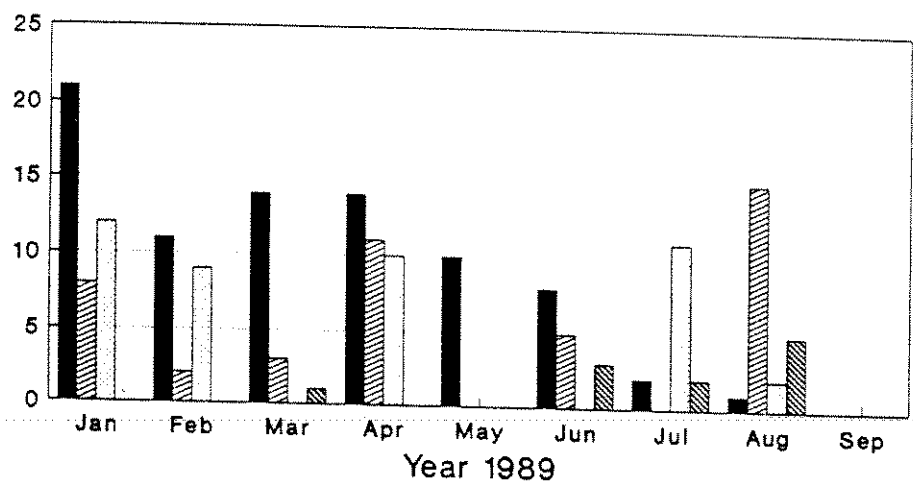
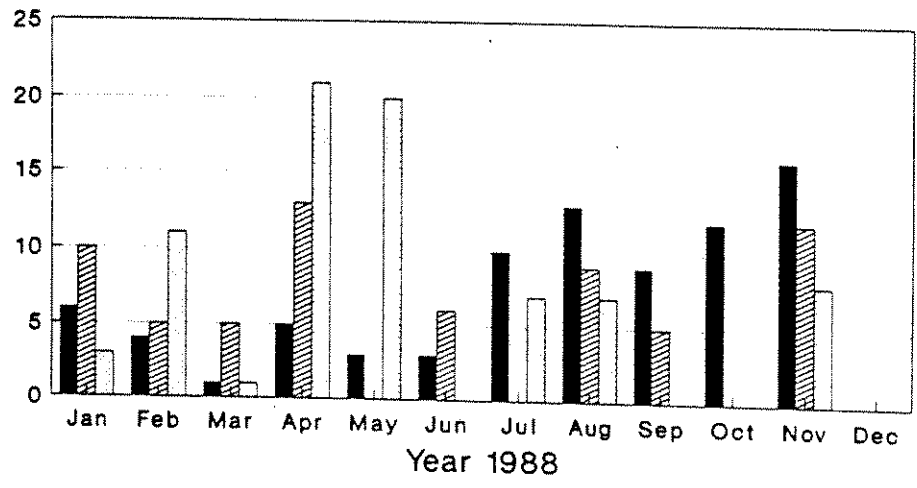

LAGEOS
 STARLETTE
 AJISAI
 ETALON-1

Figure 1: Number of passes of SRS Wettzell in 1988 and 1989.

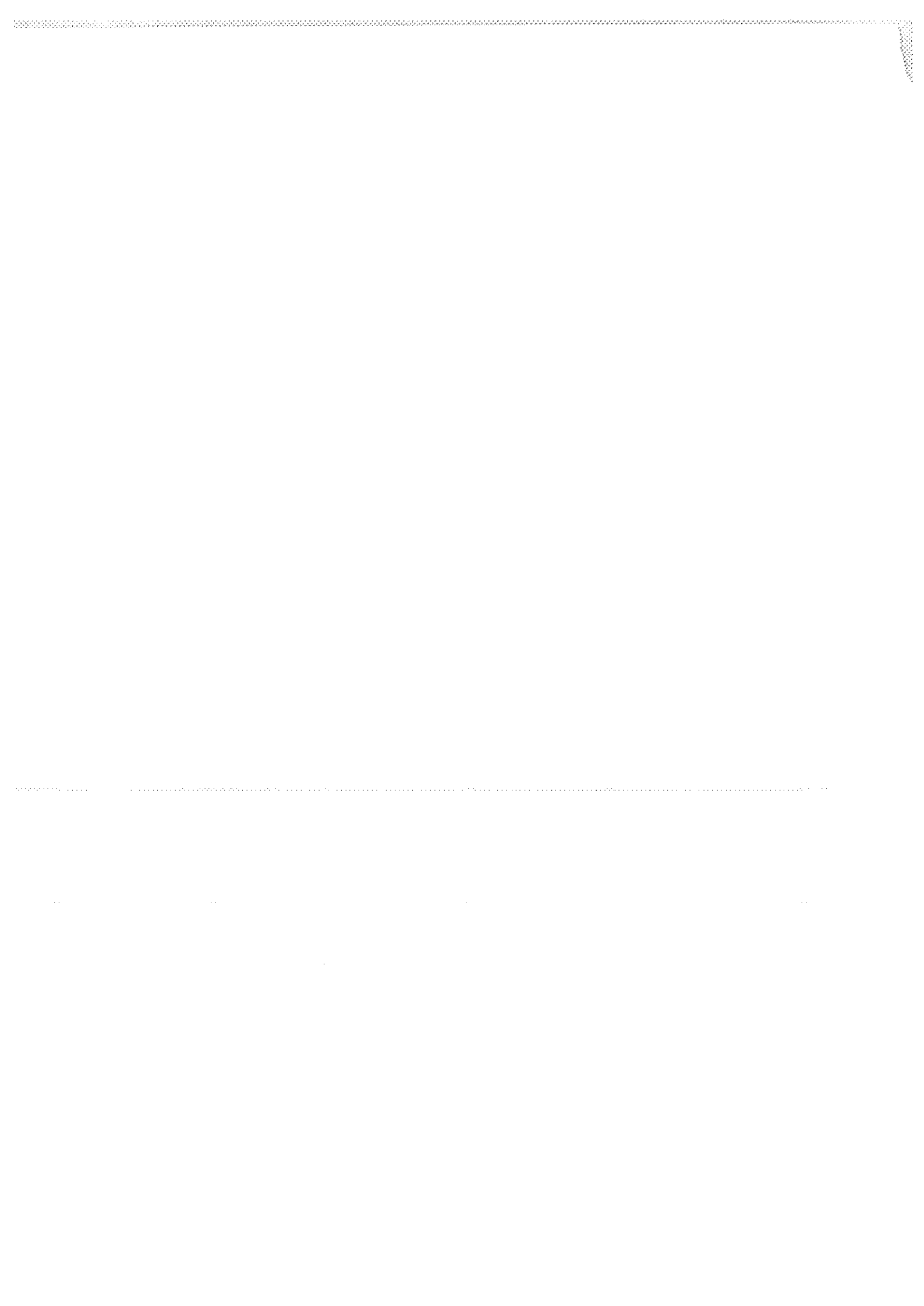

STATUS REPORT ON THE NEW WETTZELL LASER RANGING SYSTEM (WLRS)

REINER DASSING, WOLFGANG SCHLÜTER
INSTITUT FÜR ANGEWANDTE GEODÄSIE
FUNDAMENTALSTATION WETTZELL DER
FORSCHUNGSGRUPPE SATELLITENGEODÄSIE
D-8493 KÖTZTING

ULRICH SCHREIBER
FORSCHUNGSEINRICHTUNG SATELLITENGEODÄSIE
DER TECHNISCHEN UNIVERSITÄT MÜNCHEN
FUNDAMENTALSTATIONSTATION WETTZELL
D-8493 KÖTZTING

Abstract. The new Wettzell Laser Ranging System (WLRS) will replace the 3rd Generation GTE-Sylvania Satellite Laser Ranging System. It is designed as a dual purpose system, in order to range to artificial satellites and to the moon. This paper describes the current status of the system.

1. Introduction

The Wettzell Laser Ranging System (WLRS) is currently set up and will replace the GTE-Sylvania Satellite Laser Ranging System, which has been operating at the Satellite Observation Station Wettzell since 1976. The WLRS is designed for

- ranging to artificial satellites,
- ranging to the moon.

The general concept of the system is very similar to the

- MLRS (McDonald Laser Ranging System, Texas)
- NLRS (NatMap Laser Ranging System, Orroral, Australia)

The design has been worked out in close cooperation with experienced LLR-specialists. It was published in [Schlüter et. al., 1984]

The main optics and mechanics, such as the telescope and the guiding station have been supplied by the manufacturer Carl Zeiss, Oberkochen/West-Germany. The ranging electronics, the Transmit/Receive (T/R) system, the computer interfaces and the real-time ranging software have been provided by the Australian Trade Commission (AUSTRADE), Sydney/Australia, whose subcontractor Electro Optic System (EOS), Canberra/Australia has taken over the technical realisation. Currently the system integration is in progress.

The general objectives of the WLRS are:

- day- and night-time capabilities;
- high degree of automation;

Typeset by $\mathcal{A}\mathcal{M}\mathcal{S}$ -TEX

- modular set up for integration of future technologies;
- accuracy at the state of the art;
- real-time calibration and terrestrial target calibration;
- easy to maintain by using experienced standard technology.

2. Telescope and Mount

The Telescope and the ALT/Az-Mount have been developed by the manufacturer C. Zeiss (fig.1 and 2). The installation at Wettzell was completed in July 89. It is a 75 cm telescope, the reflecting surfaces are silver coated with high reflectivity in the visible and infrared part of the spectrum. To avoid pollution by dust and moisture the telescope and the Coudé path are sealed by two entrance windows and slightly overpressured. The Laser beam before entering the Telescope is expanded by a factor 5 to a 10 cm beam by a C. Zeiss beam expander.

From first results using a mount-model the pointing of the Telescope is expected to be better than 2 arcsec.

3. Guiding Station

The guiding station (figure 3) was installed along with the Telescope. It permits guiding

- visuelly via an eye-piece;
- with a TV-camera;
- with a star-sensor;

Additionally a photcamera is attached.

4. Transmit/Receive-System (T/R-System)

The switching between the transmitted laser pulse and the return pulse from a remote target is realised by a rotating mirror. A hole in the mirror facilitates the transmission, the rotating mirror reflects the returning signal to the detector. Two detectors are employed. A PMT RCA8850 and a MCP. The modular set up of the T/R-System makes it easy to exchange detectors, e.g. Avalanche Diodes [Schreiber et. al 1989]. The T/R-System (figure 4) is manufactured by EOS and completely installed.

5. Laser

A Nd:YAG Laser Type: Quantel Mod YG 402 DP has been employed. To optimize power, beam profile and system performance the laser has been modified by

- replacing mechanical holders for the lenses;
- removing the double pass amplifier and employing two single pass amplifiers;
- exchanging the original capacitor banks for simmered capacitor banks.

The Laser can be operated in three different modes

- single pulse (100 ps, 100 mJ at 532 nm)
- pulse train (4 – 8 pulses, 300 mJ at 532 nm)
- Q-switch (3 ns, 400 mJ at 532 nm).

The pulse repetition rate is variable from 1 to 10 Hz.

6. Electronics and Timing-System

Essentially the electronics can be grouped into:

- master ranging control system;
- dome controller;
- handpaddle controller;
- meteorological interface;
- T/R electronics.

All the components were built by EOS.

The timing system is an epoch-timing system employing 4 CAMAC TDC Le Croy 2229 (Time to Digital Converters). The precision of the timing system is specified to be less than 10 ps after being modified. The timing system can be calibrated by optic and electronic delay lines.

7. Software

The software package is split into two sections, the real-time software and the prediction- and analysis software. The real-time software was developed by EOS, the prediction- and analysis software has been written by IfAG and the FES (Forschungseinrichtung Satellitengeodäsie of the Technical University Munich).

The real-time software consists of the ranging software (satellites, lunar and terrestrial targets inclusive simulation), the calibration-, testing- and simulation software and the mount-modelling. The software is currently implemented on the HP A900 computer.

A preliminary prediction and analysis software has been installed. A new software has been developed by the Forschungseinrichtung Satellitengeodäsie at the Technical University Munich and will be made available soon. Taking into account the increasing on-site-data-reduction process the software is written for a workstation with UNIX operating system which will be connected via LAN to the real-time HP A900 computer.

8. Status and plans of WLRS

All the hardware is available and has been installed. The software is currently installed and the system integration has been commenced. First satellite tracking tests can be expected in winter 1989, lunar tracking tests not before the spring 1990. The system will not be operational before spring 1990. As soon as the system works on an operational basis parallel observations have been scheduled with the old SRS.

REFERENCES

- W. Schlüter, G. Soltau, R. Dassing, R. Höpfl, *The Concept of a New Wettzell Laser Ranging System with Dual-Purpose Capabilities. paper presented to the 5th intern. workshop on Laser Ranging Instrumentation, Royal Greenwich Observatory, Herstmonceux Castle, England, 1984.*
- U. Schreiber, N. Brandl, D. Feil, K.H. Haufe, *The Usage of Semiconductordetectors at the WLRS. Paper presented at the 7th intern. workshop on Laser Ranging Instrumentation, Matera, Italy, 1989.*

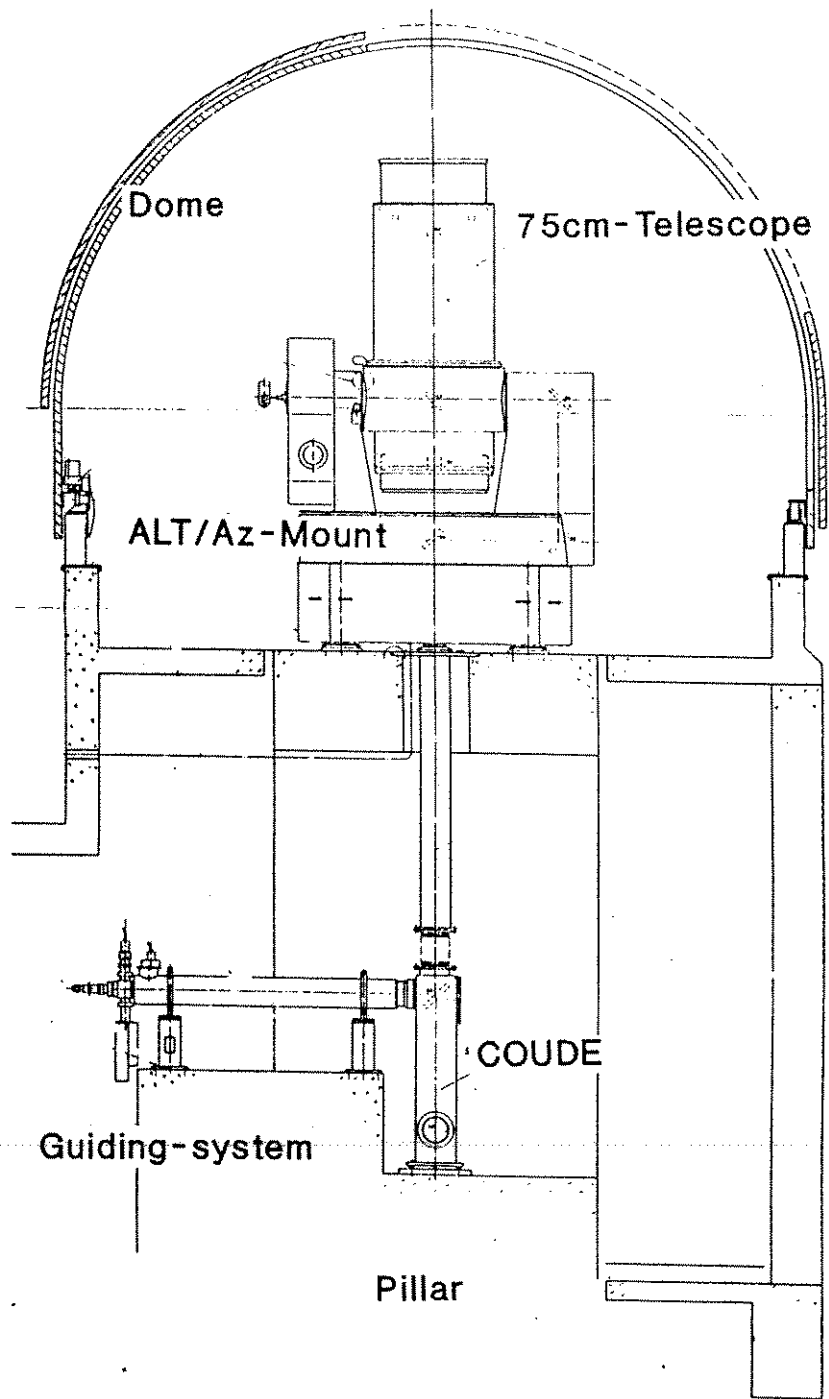

Figure 1: Scheme of WLRs telescope and guiding station, prov. by C. Zeiss

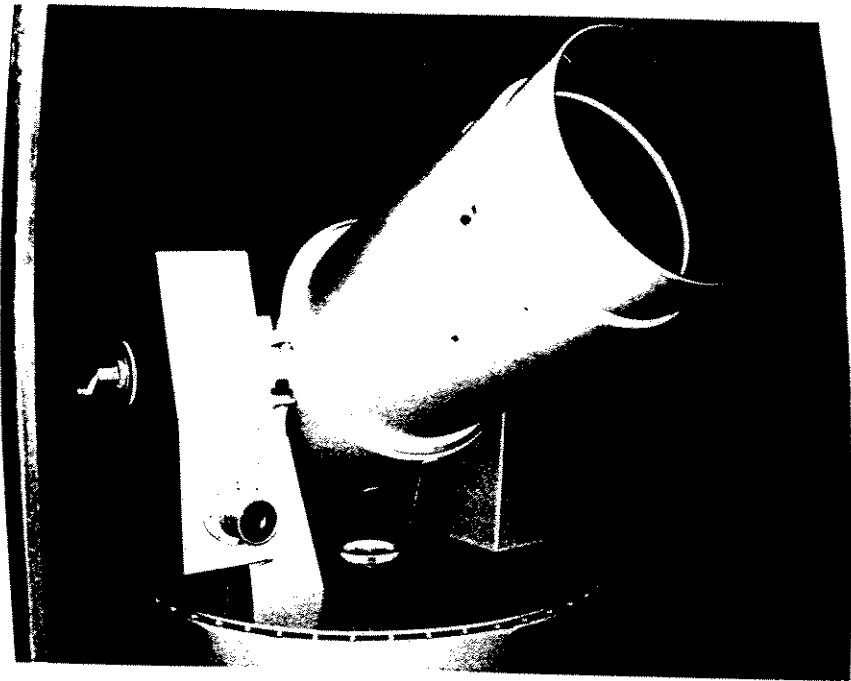

Figure 2: WLRs telescope

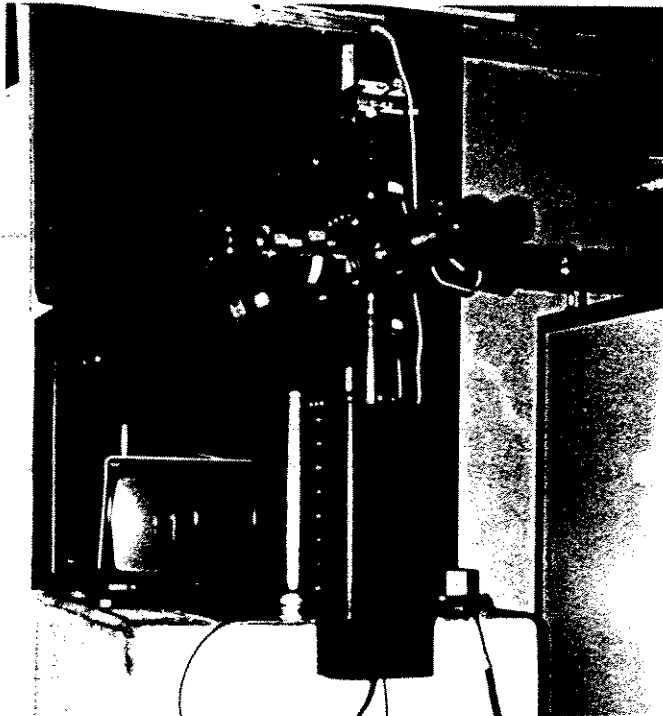

Figure 3: WLRs guiding station

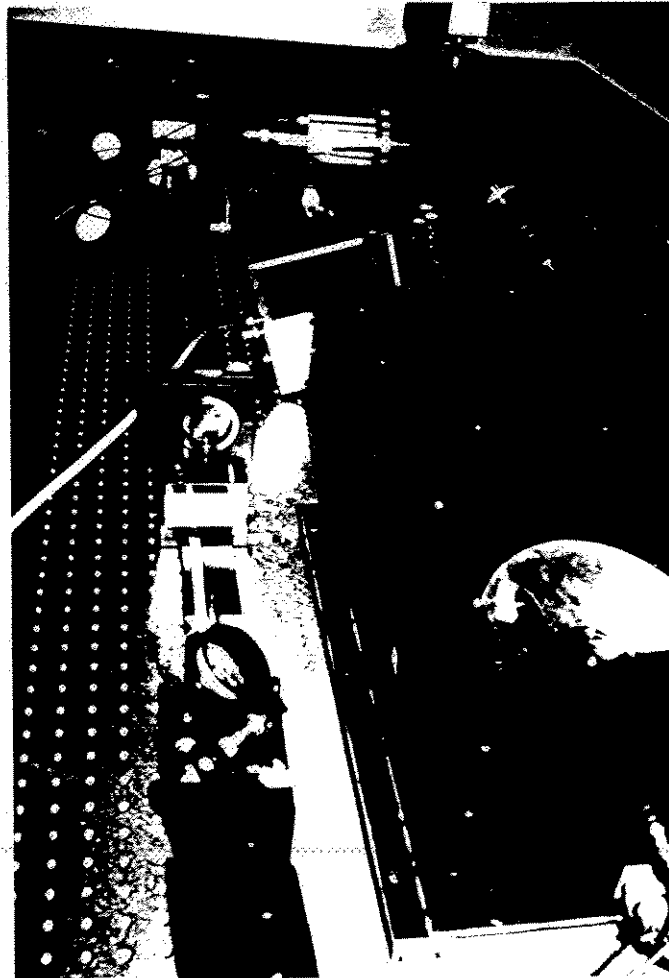

Figure 4: WLRs transmit/receive system

GRASSE SLR STATION

STATUS, RESULTS AND FUTURE

BY F. PIERRON

and the Laser staff (E. CUOT, J.L. HATAT, M. LAPLANCHE, J. PARIS)

CERGA-GRGS-CNES

SUMMARY

Station evolution
results
Operating mode
Etalon ranging
next steps and future

MATERA
SEPTEMBER 1989

OBSERVATOIRE DU CALERN
CAUSSOLS
06460 SAINT VALLIER DE THIEY
FRANCE
TELEX:461402F
SPAN:29211::PIERRON

STATION EVOLUTION SINCE 1984:

-END 1984: RUBIS--> YAG LASER

=====>Accuracy immediatly ameliorated to 2.5 cm single shot
But poor operationnal capabilities (200 passes/year)
Preprocessing very heavy
Data transmission problems

-1986:

* Computer changed to DEC PDP 11-73 for more powerful processing

* NEW Software fully developped

Predictions in the station
Preprocessing in the station
Real Time Process Control

=====>Operationnal capabilities increased by a factor 2 (470 Passes/Year)

-Early 1987: Test Period

For -The new software
-New devices

In the mean time: Study and engineering

*Calibration methods
*Daylight tracking
*Automation in order to have the station operated by one observer only

OPERATIONS SINCE END 1987 :

-ADDITIONAL ENGINNEERING TO GET DAYLIGHT TRACKING IMMEDIATLY SUCESSFUL (OCTOBER 1987)

-AUTOMATION OF THE PROCEDURE TO OPTIMIZE AND SIMPLIFY THE OBSERVER'S WORK

-CONNECTION OF THE STATION TO:

-EARN-BITNET for fast report and Mail

-MARKIII for Quick-look dissemination every day

-SPAN for message and data exchange

-CALIBRATION stability ameliorated with new system (optical square)

-RMS Single shot on satellite from 1.0 to 2.5 cm depending essentially on the return level dynamic range adjusted by the operator.

-SYSTEMATIC acquisition even in summer time by daylight with a thin mist of LAGEOS, AJISAI, STARLETTE, ETALON 1 et ETALON 2.

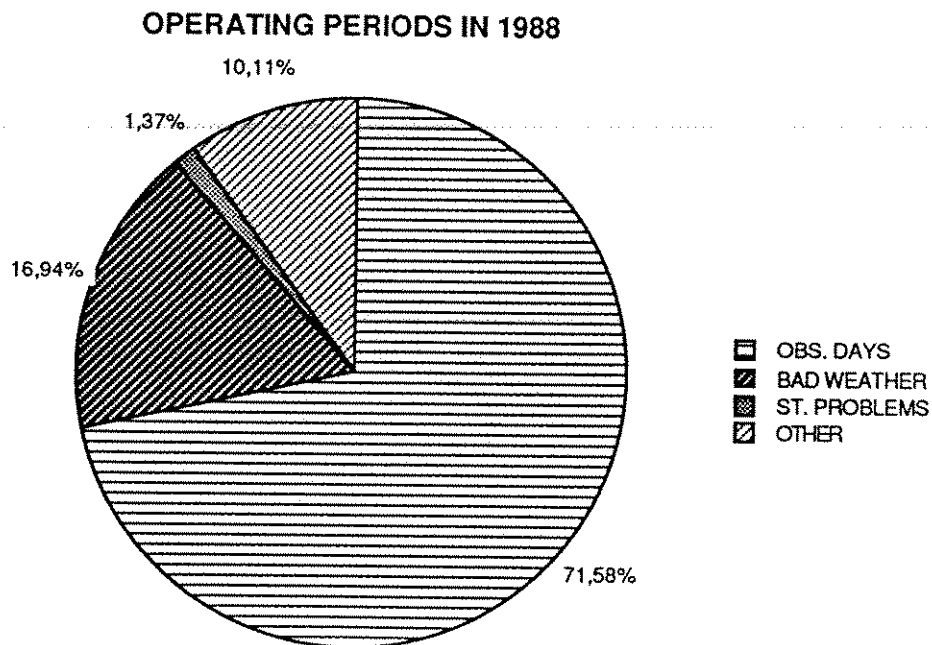

Number of passes: 1985 - 1989

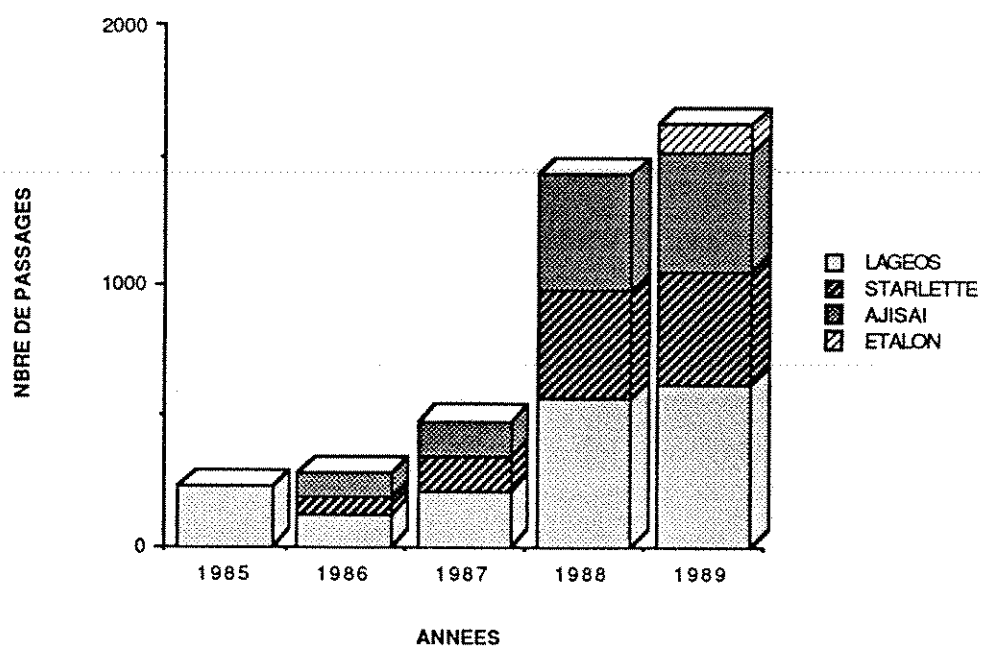
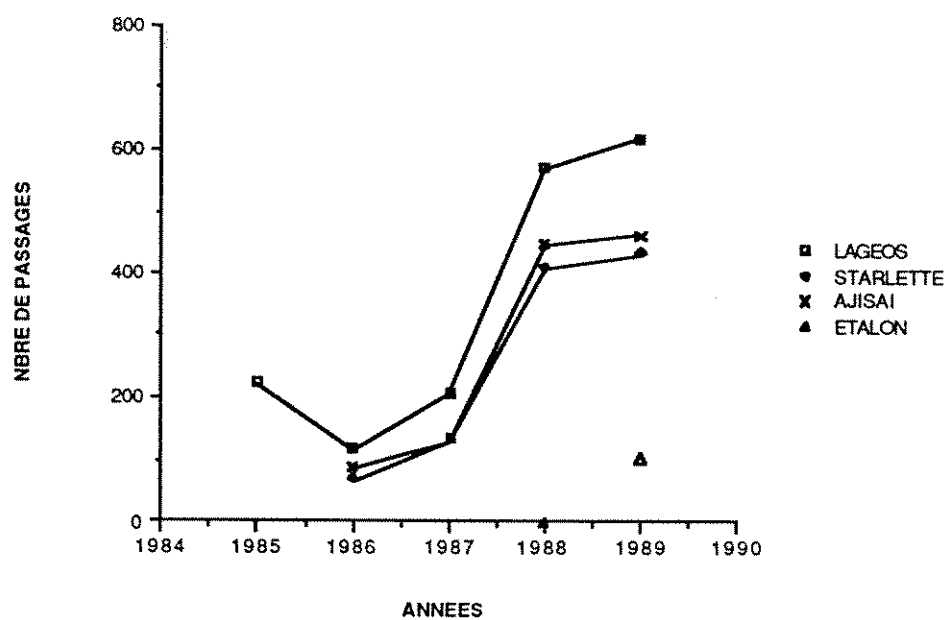

OPERATING MODE

- *Total staff: Five people
- *One observer only to operate the station in semi- automatic mode during day or night time.
- *Preprocessing of the data achieved by the technician immediatly after the pass.
- *Transmission of the Quick-look data to GLTN once a day by MarkIII network today and through SPAN in a near future.
- *Dissemination of the magtape in the definitive format usually in two weeks after the end of a month.
- *Operating 24 hours a day during 5.5 days a week.
- *Ranging of five satellites: Lageos, Starlette, Ajisai , Etalon1 and Etalon 2.

ETALON 1 ET 2 RANGING

- FIRST RETURNS OF ETALON 1 obtained in february 1989
- FIRST RETURNS OF ETALON 2 obtained in September 1989
- LINK BUDGET SLIGHTLY WEAKER THAN LAGEOS
- NUMBER OF RETURNS/PASS
1000--->5000 /PASS
THREE OR FOR PERIOD 15-20 MIN /PASS in order to compute normal points.
- RANGING OF ETALON BETWEEN THE OTHER PASSES
--> 5/15 PASSES/MONTH SINCE 1- MARCH 1989.

ETALON 2 PASS

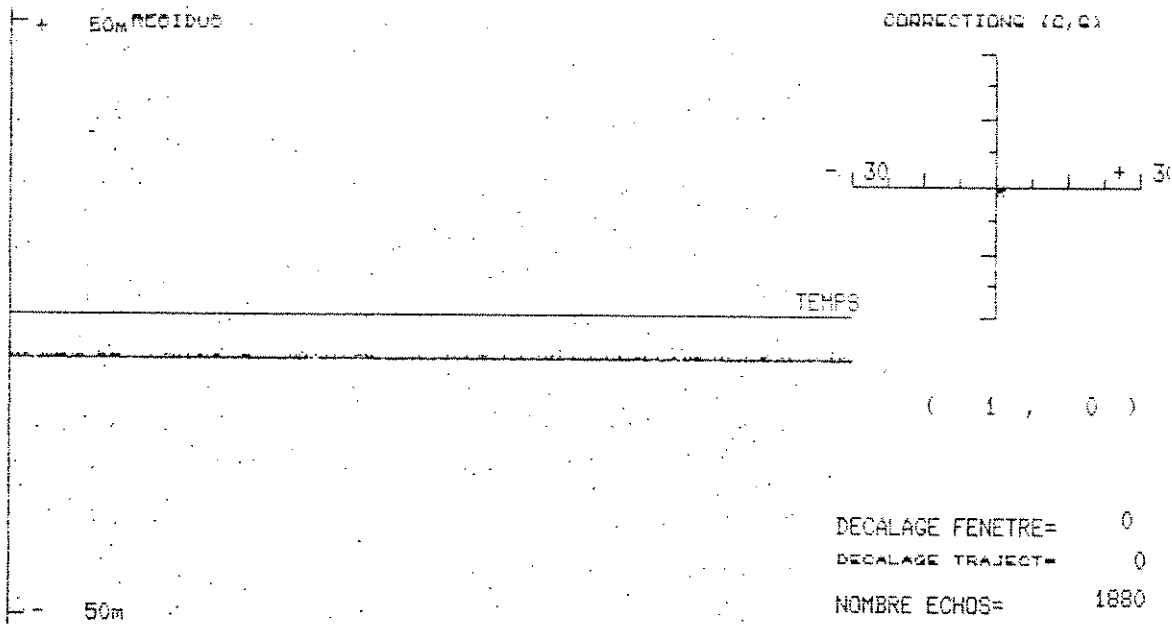

**DAYLIGHT TRACKING(11 H UTC)
28 SEPTEMBER 1989**

NEXT STEPS AND FUTURE

-**Automatisation** in order to reduce the volume of work particularly during the night time and to increase the number of observations.

-Fitting out the system to do easier the switching from one satellite to an another and going back.

-**Colocation** with a mobile SLR station as soon as possible.

-**Global accuracy improved** at the centimeter level with a new detector device (MCP, Photodiode,...)

-**High level in term of number of passes maintained** (Night and daylight ranging,...)

-**Engineering of a higly mobile SLR station:**

*Calibration of TOPEX-POSEIDON to be launched in 92 or any oceanographic satellite such ERS 1.

*Ranging of Geodetic satellites from locations difficult to reach with the actual systems for scientific goals.

CONCLUSIONS

*In spite of growing interest for Mobile Laser System, there is still a specific interest of a heavy fixed station.

-Large telescope (1 meter)

-Powerful laser (200 milli joules/shot)

=====>Many passes capability tracking with a very poor staff
1430 PASSES in 1988 with 5 people.

*Need of close cooperations and very fast feedback with all
the analysis centers.

*Need to have discussions about scheduling observations with the
number increasing of satellite to range in the near future in taking account
scientific goals approved by the different groups.

*Need of an agreement on a method to compute normal points in
station reducing the volume of data transmitted.

THE CERGA LUNAR LASER RANGING STATION

October 1989

Ch. Veillet	Astr. (manager)
E. Bois	Astr.
J.E. Chabaudie	Tech. (observations)
Ch. Dumoulin	Ing. (mechanics/optics)
D. Feraudy	Tech. (observations/analysis)
M. Glentzlin	Tech. (analysis)
J.F. Mangin	Ing. (electronics/laser)
J. Pham-Van	Astr.
J.M. Torre	Tech. (electronics/laser)

*Centre d'Etudes et de Recherches Géodynamiques et Astronomiques
Observatoire de la Côte d'Azur
Av. Copernic
F-06130 GRASSE*

*Telephone : 93 36 58 49
Telex : 470865 CERGA
Earn/Bitnet : VEILLET@FRONI51
Span : OCAR01::VEILLET
GE Mark3 : SLLC*

Abstract

The main characteristics of the CERGA Lunar Laser Ranging station are presented : telescope, laser, transmitting/receiving/pointing package, computer environment ... Statistics on return rates and accuracy are shown and future plans for automation and ranging at $1.06 \mu\text{m}$ are described.

1/ Introduction

The CERGA LLR station got its first returns from lunar retroreflectors in 1981. Since that time, the data improved continuously in quantity, diversity (various reflectors) and accuracy. In June 1986, the ruby laser (3J/3ns pulse and 10 shots per minute) fired for the last time, and the implementation of a new YAG laser started together with various changes in the transmitting/receiving/pointing package. The first returns with the new equipment were recorded in September, and the first night with normal points suitable for Earth rotation in November 1986.

The first nine months in 1987 have been lost for various problems (laser damages, computer breakdown, bad weather in Spring, and finally breakdown of the CERGA time service in Summer after a thunderstorm). The laser fired again in October. Returns came back very rapidly, and since that time, the station is operational on the four reflectors, with daylight capabilities on a clear sky. The first returns at $1.06 \mu\text{m}$ have been obtained on Meteosat P2 in March 1989, and on the Moon in September 1989.

2/ The telescope

Figure 1 presents a general view of the station. The alt-azimuthal telescope is used for transmitting the laser, receiving the returns and pointing the target. Its main mirror is 1.5-m in diameter, and the Cassegrain Nasmyth configuration gives 30 m in equivalent focal length.

The laser beam comes from the contiguous building and enter the telescope through its vertical and horizontal axes. All the mirrors along the path before the telescope tube are coated for $1.06 \mu\text{m}$ and $0.53 \mu\text{m}$, so that the two wavelengths of the laser are sent to the target. The first (flat) mirror in the tube is now silver coated, and the secondary mirror should receive the same coating soon.

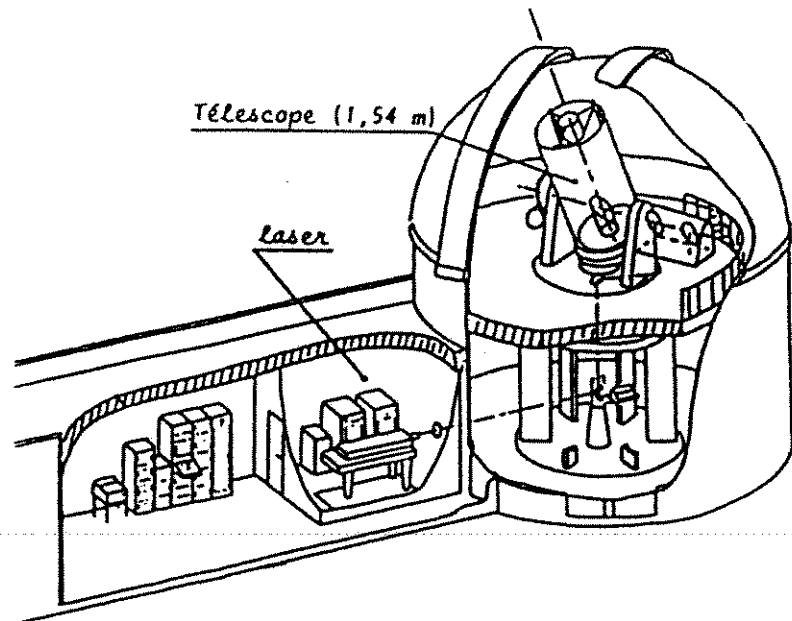

Fig. 1 - Station configuration

The transmission reception switch system as well as the guiding optics and the reception package (pinhole, filter and photomultiplier) are located on a table fixed on the telescope fork (see paragraph 3 for further details). This table moves with telescope azimuthal motion.

3/ The laser

Fig. 2 shows the implementation of the new Quantel Nd-YAG laser components on the granite. The oscillating cavity can work in both active/passive (dye cell) or active/active modes. After the slicer, each pulse is 0.3 mJ in 300 ps in active/active mode, or roughly 4 mJ in 200 ps in active/passive mode, both at a 10 Hz pulse rate and in infra-red. Two consecutive 7mm rod amplifiers permit to reach 70 mJ in active/active mode. In the original configuration (only used for

the first months of operation), this pulse is divided in two equal pulses, both of them being finally amplified on its own third amplifier (9mm rod), a delay line insuring a simultaneity of the start at the granite edge. The final energy is 600 mJ in infra-red per 300 ps pulse and per beam at 10 Hz. In the present configuration (Oct 89), only one beam is used. After the matching lens, this laser beam fills all the telescope aperture.

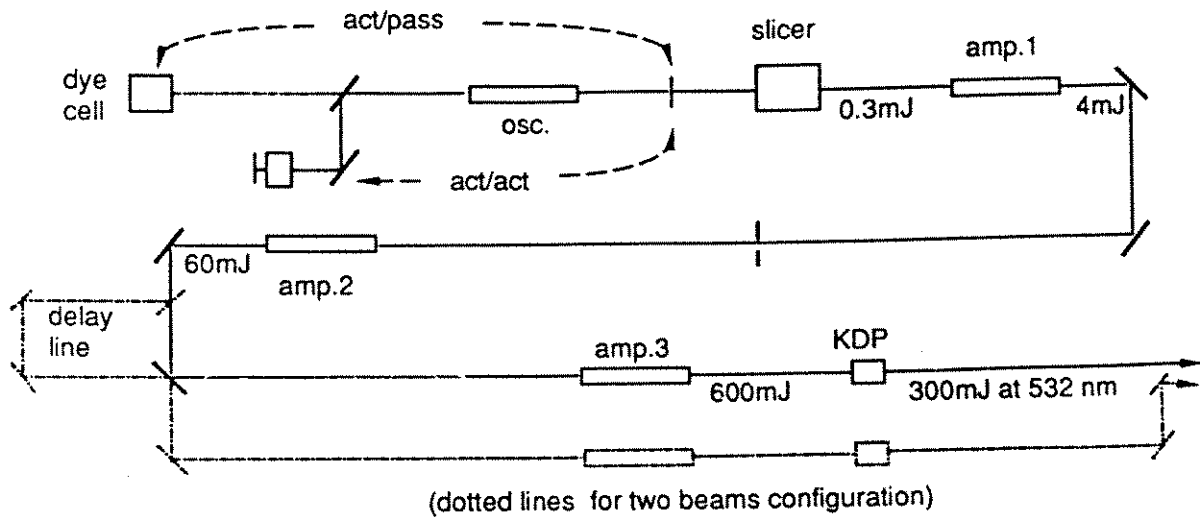

Fig. 2 - Laser configuration - Energies are given at 10 Hz rate for 300 ps pulses.

By changing the Fabry-Perot glass at the cavity output edge, other pulse lengths in active/passive mode can be obtained down until 35 ps. They can be used for example for accuracy tests on the electronics. If the active/active mode is easier to work with (there is no dye check and maintenance), it can be less stable. As this mode is currently used, and in order to improve the stability, a focalisation point has been added to the original configuration between the first and the second amplifier.

4/ The transmitting/receiving/pointing package

The general design of this package is shown on Fig. 3. This system is mounted on the telescope and is moving with the telescope azimuthal motion. It has been designed in order to minimize the number of optical components encountered by the returns. The transmitted beam is entering the telescope after the matching lens (ML) and a reflection on a rotating mirror (RM1). This mirror itself starts the laser when set in transmission position. Its speed is monitored by the computer in order to insure that the returns are entering the receiving path through the hole of the second rotating mirror, in fact a rotating hole (RM2). RM2 allows to send the pointed field on a CCD camera and then to view the pointed area on a TV screen when RM1 is not transmitting nor RM2 receiving (most of the time).

A diaphragm adjustable from 7 to 60" is located at the telescope focus (F) on the return path. A dichroic glass (D) sends the green returns on the PMT through the filter wheel (FW) within an afocal system. The red way is available in R, where an avalanche photodiode can be used for receiving at 1.06 μm .

The internal calibration path is shown on the same figure. The light transmitted by the first mirror M1 (lower left) is sent on the receiving package through neutral densities (ND) for

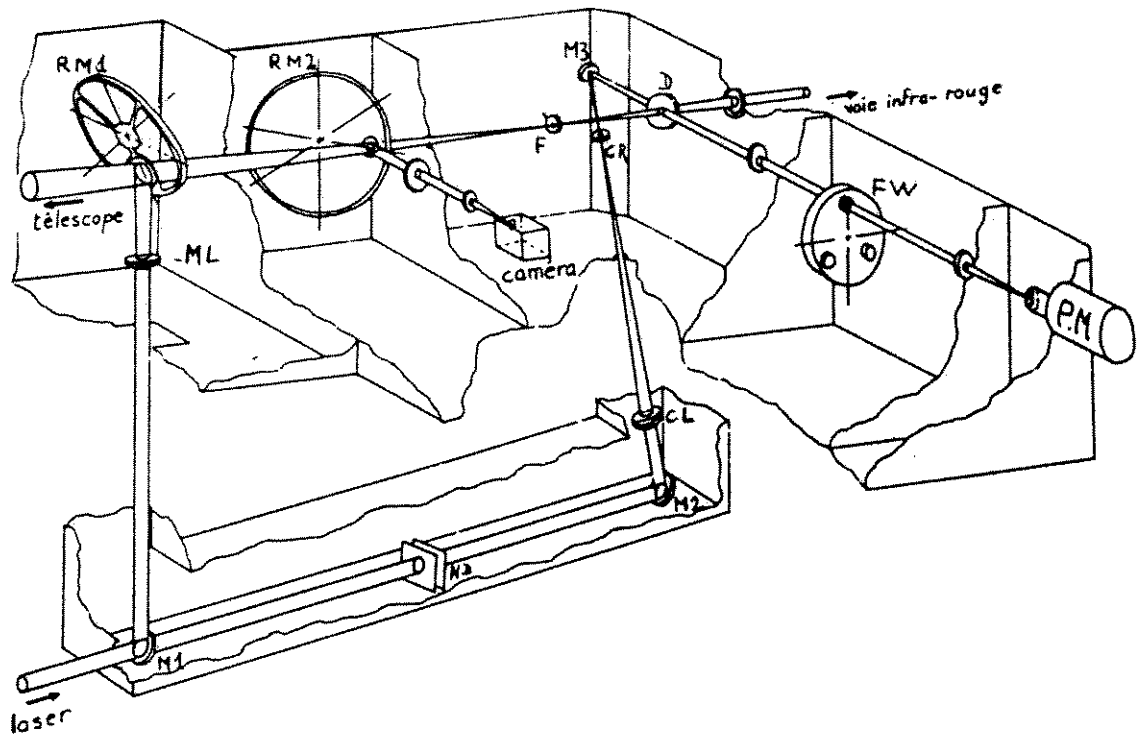

Fig. 3 - Transmitting/receiving/pointing package - See text for information.

attenuation, a second mirror M2 and a converging lens CL focusing the calibration in a point CF conjugate of the telescope focus. After M3, the calibration go through the dichroic glass (D) and follows the return path till the PMT.

5/ The computer and its environment

The computer (PDP 11/73) has been installed in September 1985 and has monitored the ruby station ten months before the laser change. Its environment is shown on Fig. 4. The main characteristics of the configuration is that the PDP is not concerned with telescope pointing and guiding. At the beginning of each observing session, the data needed for pointing the Moon (9 reference craters and the five reflectors) and close stars are sent from the PDP to a microcomputer IBM PS/2, replacing since September 1989 an old Victor S1. Many programs are under development on this much more powerful microcomputer, adding many possibilities to the main pointing software : automatic scan of the sky up to a given magnitude for determination or update of the mount model, automatic pointing, ...

Thus the PDP is only busy with the real time monitoring of the station : rotating mirrors enslavement, event acquisition (laser starts, internal calibration and in gate events), gate commands, ... The event-timer has one channel for the laser start and three others for events (calibration or/and gate events). Its resolution is 50 ps. A link is established between the PDP and a CCD camera used for pointing stars or features on the Moon. It could be used for an automatic pointing done on the PDP, or on the new IBM computer (see below). A data processing is made at the end of each series providing with the normal point (if there are identified returns). At the end of the night, these data can be used for a UT0 determination.

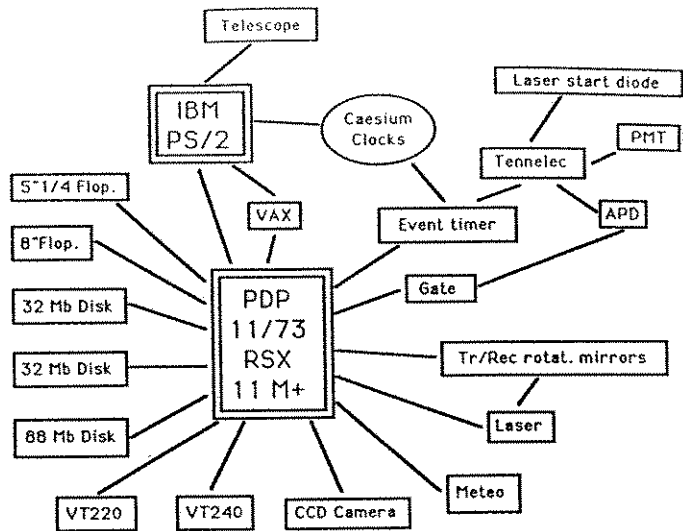

Fig. 4 - Computer environment

The PDP is linked to the VAX computer located at the CERGA down and the normal points can be sent from the station on the VAX and from there on the CNES CDC computers.

6/ The first two years of operation

The system described here is operational since October 1987. On the last page of this paper are displayed the data rate for the last 16 lunar months in returns and normal points for each of the three operational stations (Haleakala, Mc Donald and CERGA).

With the best conditions (very transparent sky), the return rate can reach 20 returns per minute, each normal point accumulating data for a maximum of 12 minutes. The average number of returns per normal point is displayed on Fig. 5 for each of the four retroreflectors, and the distribution of the data with the target is shown on Fig. 6.

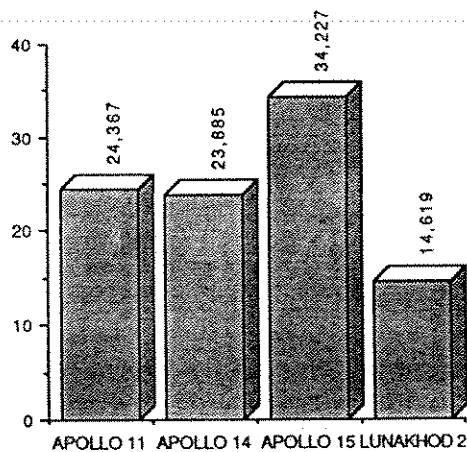

Fig. 5 - Returns average per normal point

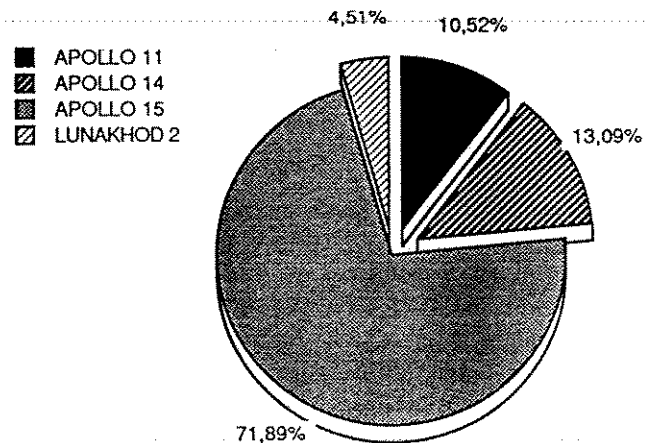

Fig. 6 - Normal point distribution per reflector

Various analyses of the CERGA YAG data (starting in September 1987) show that the accuracy of the distance measurement is at the two centimeters level. In fact, the found root mean square

of the residuals against a model of the Earth-Moon system depends on the data as well as on the model itself. What is clear is that the rms of the residuals after a fit of UT1-UTC is often less than 1 centimeter.

7/ Ranging Meteosat P2

The CERGA LLR station has been very busy for the European phase of the LASSO experiment (time transfer by ranging a geosynchronous satellite carrying a laser pulse detector and a very stable oscillator). It has been the only one station able to give datations on board, and the main source of ranging data ... Many tests have been on the LASSO package by the station. As Meteosat P2 will be moved at 50 degrees West, the second phase of the LASSO experiment will take place within the next two years and should permit time transfer between Europe and USA. The CERGA LLR station will be the only one able to range from Europe.

Fig. 7 shows a ranging session to Meteosat P2 with echoes obtained in two wavelengths.

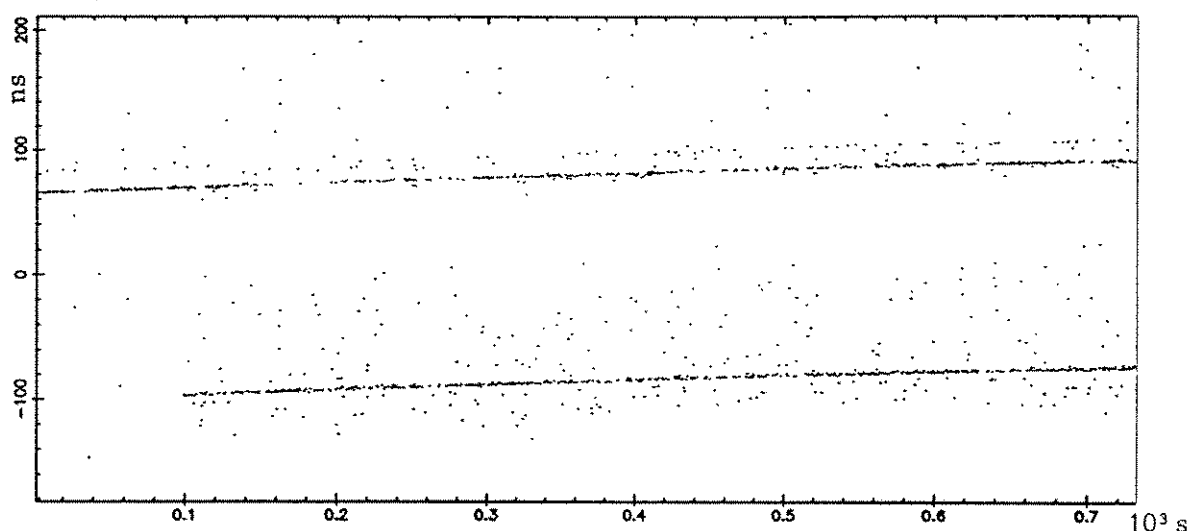

Fig. 7 - A ranging session on Meteosat P2. Each dot is a photon detected by the PMT (top) and the Avalanche photodiode (bottom) and put at its position in the gate (vertical axis) with respect to its arrival time (horizontal axis).

7/ Ranging at 1.06 μm .

As the number of returns coming back from the Moon is very low, any way of increasing this number is welcome for LLR ... It is possible to increase the energy of the laser, the efficiency of the receiver, or to use a wavelength less affected by the atmosphere. Working at the original wavelength of the YAG laser, 1.06 μm (IR), seems promising as the energy can be twice what one gets after frequency doubling, the receiver (avalanche photodiode) is much more efficient than a PMT, and the atmosphere is better, mainly with a low Moon and a sky not very clear.

The studies of an avalanche photodiode started at the end of 1988, and the first echoes have been obtained on Meteosat P2 at the two wavelengths at the same time (see Fig. 7 for an exemple of such a ranging session). After some improvements, it worked successfully on various satellites (Lageos, Etalon, Meteosat P2) and finally on the Moon, as shown on Fig 8.

A careful study of the ranging data obtained in the Summer 1989 should permit to qualify the IR way of the station in terms of sensivity and jitters. It could confirm that the IR is much more efficient than green, as it has been seen on some tests on a far target (like Meteosat P2). The further attempts to the Moon will anyway definitely bring to a conclusion on that point.

7/ The future ...

The infra-red operations are clearly our first goal, as it has been explained earlier. As the laser can work with short pulses, it should be possible to work with all the train and 35 ps pulses in green

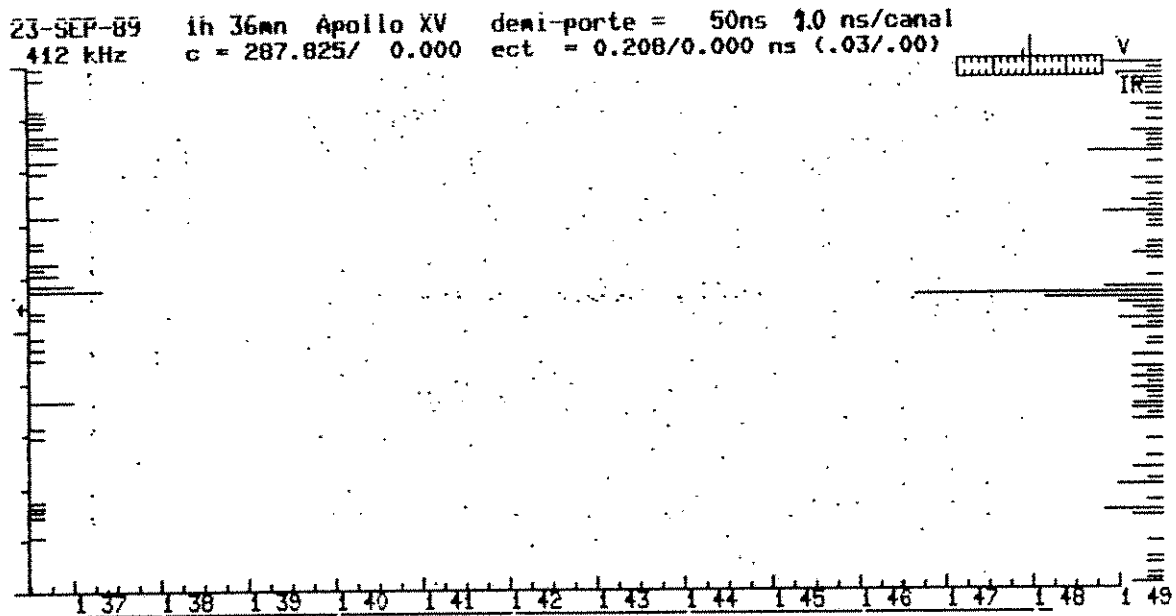

Fig. 8 - A ranging session on the Moon. Each dot is a photon detected by the PMT (green) or the avalanche photodiode (IR) and put at its position in the gate (vertical axis) with respect to its arrival time (horizontal axis). The histograms add the returns in a 1 ns bin in green on the left, and in IR on the right. The peaks on each side indicate the presence of echoes ...

and IR. Thus, by improving the datation devices, two-colour ranging for atmospheric modelling could be achieved at least on close targets (artificial satellites).

The second one is to automate the station. The present schedule of the station (20 sessions per lunar month, some of them with daylight, LASSO observations and satellite ranging for collocation) are a heavy charge for the crew, as two people are needed for the observations for safety considerations on long working periods (often more than ten hours). An automatic LLR station could be handled with only one people switching on all the components of the station, checking that everything looks good, and sleeping for most of the time if needed. The main computer of the station will take care of the observing strategy, the pointing of the telescope on a star close to the Moon, the real time operations during a series of shots (usually 12 minutes at CERGA), processing the data for return identification, and choosing the next target according to what have been obtained in the previous series. Independent devices will detect rain problems or computer traps for example, and any problem will awake the observer.

The software for the automation is already written and tested. The main (but easy) remaining task is to link the computer to various hard components (filter wheel, pinhole, ...). Tests have been made for linking the computer and the CCD camera, but this link has to be operational, and can perhaps be used more efficiently on the IBM PS2. A complete automation of the station should be operational before the end of 1989.

The last point, but not the least ..., is a continuous effort for reaching the best accuracy achievable with the present station, and with some changes in the datation package. It will need a careful study of the error sources in the equipment.

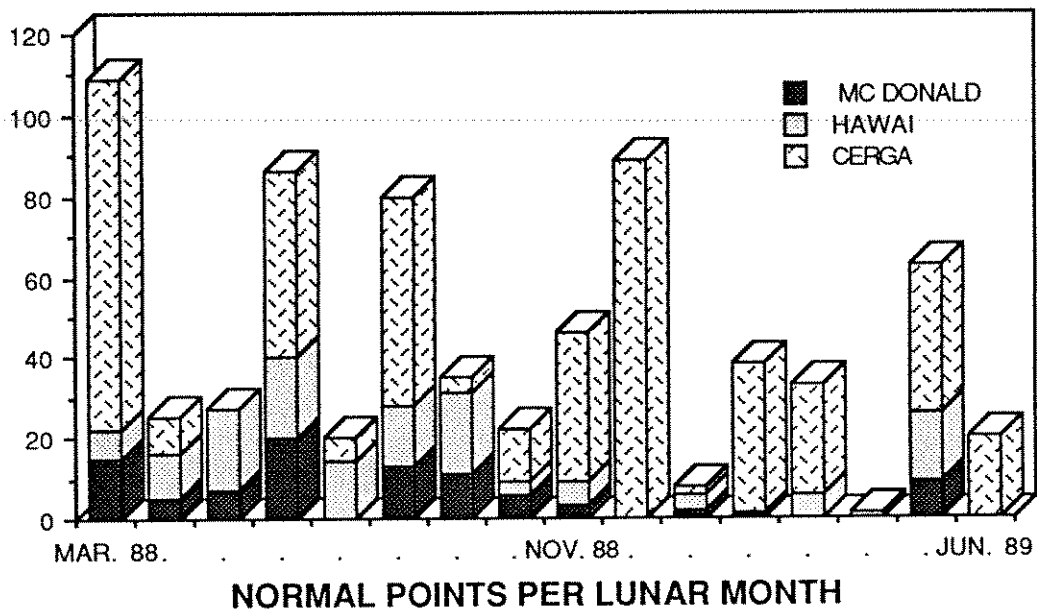
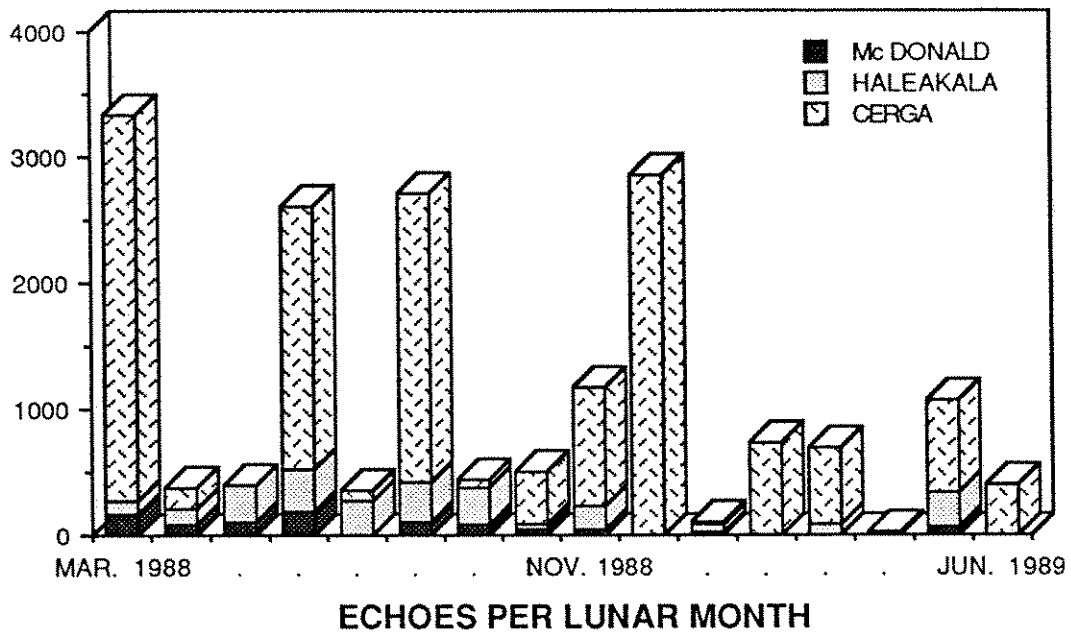

Laser technology



SOME CONSEQUENCES OF USING VERY SHORT PULSES FOR SATELLITE LASER RANGING

Contact : Bob Hyde

267, rue du Chateau du Roi,
F-38220 VIZILLE, France

The apparent need for higher precision in satellite laser ranging may be satisfied by using shorter pulses, but this solution begs several questions which I would like to address.

At present (third generation) a typical system emits single pulses of about 20mj/100pS at a repetition rate of 10Hz, wavelengt 532nM. The pulse at the laser, has a peak power of 2GWatt, repeats at 100MHz, and is generated at a wavelengt of 106nM. The reasons for generating one system and transmitting another were aguable in 1975 but not in 1989.

If one considers an evolutionary design, a fourth generation system demands pulses of $< 10\text{pS}$ duration.

- a) sub-Terwatt pulses at the laser.
- b) An increased pulse spectral width of 1nM.

The practical consequences of this escalation are :

a) We enter the non-linear optical region. Briefly, at very high powers the high spatial frequency components of a beam are amplified more than the "dc" component. The result is very high diffraction and intensities greater than the optical component damage threshold. One must also be aware of the whole-beam self-focussing effect.

b) A more benign effect ; the receiver spectral bandwidth must be increased, thereby increasing the background noise. Serious systems must work with single photons in high backgrounds (solar ou lunar) and one now faces noise rates in the megahertz range.

- c) The Laser Safety levels are more difficult to achieve.

These consequences of a seemingly innocent escalation, force us to rethink the third generation approach when looking to the fourth generation.
A few of the ways one can do this are as follows :

Firstly, we must keep the optical beam spatially clean and so present the optical nonlinearity going critical. This may be done by spatial filtering (may be in a partial vacuum) and beam apodisation. The use of special optical materials with low non-linear coefficients is also feasible. Good laser design is even more essential than before.

We can also be more economical with our pulse energy. At present a system generates up to $3E18$ photons to receive a return of 1 in 5. If we look at the signal background noise equation we see the culprits are atmospheric scattering and the inverse square effect twice over. We also note that we go to great expense to obtain a non-optimum wavelength. Radiation scattering goes as one over wavelength to the fifth power. There is also the bizarre ritual of deliberately throwing away five out of six mode-locked pulses.

I have tackled these points in previous papers to this workshop, the first time at Lagonissi (1974). It is perhaps now that may be more than just a passing curiosity.

In conclusion I should like to list possible practices to save laser energy and cost :

- a) Use a laser wavelength(s) in the near infra-red, but be careful to avoid water vapour, CO₂ and oxygen absorption lines and bands.
- b) Use all of the fundamental frequency mode-locked train.
- c) Use a low jitter geiger-mode detector.
- d) Employ the best software systems team possible.

CODA :

a) When one optimises the signal to background noise equation for satellite ranging it is found that there is an optimum value for the telescope area * quantum efficiency product. Bigger is not always better.

b) It is possible in theory to vary the field of view and beam divergence in an intelligent way to optimise the inverse square law loss during a pass.

c) The total system includes the target and this should be appreciated whenever a new satellite is proposed.

d) Pulses <2pS duration are subject to significant stretching on passing through the atmosphere.

A MODE-LOCKED Nd:YAG LASER USING A SELF-FILTERING UNSTABLE
RESONATOR AND PASSIVE CO-OPERATIVE DYE AND LiF:F₂⁻ SWITCHES

Matti Paunonen, Iván Kertész[§]

Finnish Geodetic Institute
Ilmalankatu 1A
SF-00240 Helsinki, Finland

Telephone: 358-0-264994
Telefax: 358-0-414946
Telex: 19207310
Earn/Bitnet: Geodeet@Finfun

Abstract. Operation of a pulsed, mode-locked Nd:YAG laser with a self-filtering unstable resonator and co-operative passive dye and LiF:F₂⁻ saturable absorbers is described. Improved pulse shape formation and a 90% success rate were obtained.

1. INTRODUCTION

Laser ranging to satellites needs very short, powerful, low divergence laser pulses to obtain centimetre accuracy. The energy should be 50 mJ or more, the pulse duration less than 100 ps, the beam divergence less than 1 mrad and the repetition rate more than 1 Hz. Nowadays a mode-locked Nd:YAG laser oscillator with one or several amplifiers is used /1/. Mode-locked stable single mode Nd:YAG resonators produce energies in few mJ range. Therefore several amplifiers in tandem are used. Unstable resonator Nd:YAG lasers provide the best means for obtaining large output energy with good beam properties. The standard positive branch is not very suitable because of its torus shape in the near field. Recent advances in negative branch unstable resonators using a new self-filtering unstable resonator concept (SFUR) /2/ have yielded promising properties for satellite ranging, e.g. high fundamental mode volume (thus high ener-

[§] Visiting scientist from the Central Research Institute of Physics, Budapest, Hungary

gy), an almost diffraction limited beam (thus small divergence), absence of hot spots and less optical damage risks due to the spatial filter and good tolerance to mirror misalignment.

Mode-locking can be most easily produced by saturable dye absorbers dissolved in suitable liquids. Unfortunately their operation is not very stable, and the probability of good pulse generation is generally 50-90%. Operation can be improved with an additional active modulator, e.g. an acousto-optical cell. Combination of different absorbers may also have some advantages /3/. Mode-locking using solid state absorbers has been reported /4-6/, as has their combination with other types of Q-switches /7/. A solid saturable absorber, e.g. LiF crystal containing F_2^- colour centres, is a very useful device, as it has simple construction, small dimensions and no control unit /8/. To get insight into the SFUR concept a Nd:YAG laser using this resonator and available mirrors was constructed. The mode-locking properties of LiF: F_2^- crystals were also tested.

2. EXPERIMENTAL SETUP AND RESULTS

The optical layout of the SFUR resonator constructed is shown in Fig. 1. The concave cavity mirrors, M1 and M2, form a confocal resonator, whose length, L, is determined by $L = f_1 + f_2$, where f_1 and f_2 are the effective focal lengths of the mirrors. Because the longer focal length mirror, M2, is in contact with the mode-locking dye, Kodak 9860, dissolved in 1,2-dichloroethane, its focal length, $f_2 = 1.38$ m, is shorter by a factor of 1.45 (refractive index of the solvent) than the free-air value of 2 m. The dye thickness in the flowing dye cell was 0.8 mm. The radius of the filtering aperture, a, is defined by $a = (0.61\lambda f_1)^{0.5}$, where λ is the wavelength (1064 nm) and f_1 is the focal length of the shorter focal length mirror M1 ($f_1 = 0.5$ m in our case). A polished steel plate with an aperture of 1.14 mm ($=2a$) was placed at the common focal point. The aperture is designed to pass only the first Airy ring from the beam reflecting from mirror M1. The beam propagating from mirror M2 towards the aperture is parallel. The geometric magnification is defined by $M = f_2/f_1$, which is in our case $M = 2.75$. The diameter of the collimated beam is $D = 1.5M \cdot 2a = 4.7$ mm /2/. Because a Nd:YAG rod 6.35 mm in diameter and 75 mm long was used, the beam does not completely fill the rod. Owing to the long optical length of the resonator, 1925 mm, which includes the effect of the refractive indexes in the components, two 45 degree reflecting mirrors were used. Thermal lensing of the rod was thought to be slight.

The flashlamp was energized with a special pulsing system using a high power transistor switch /9/. The bore size of the flashlamp with 75 mm arc length was 4 mm. Two circular glass half-cylinders silvered on the reverse side and cut to approximate an elliptical cross section, formed the pumping enclosure. A small air blower was used to cool the rod and the lamp. In the power supply a photoflash electrolytic capacitor (1000 μ F/500 V) was used as the pulse energy

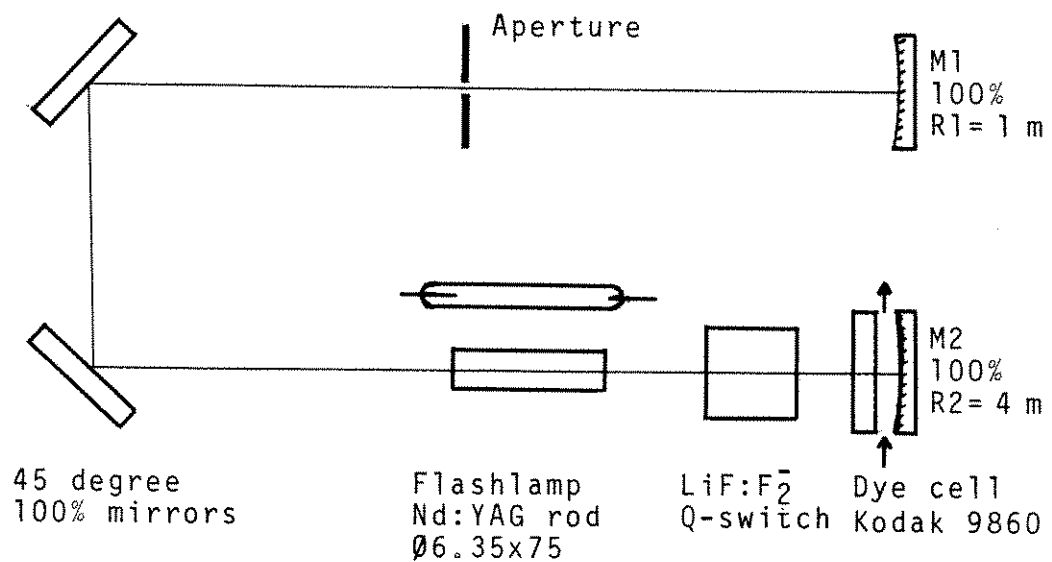

Fig. 1. Optical layout of a passively mode-locked Nd:YAG laser using self-filtering unstable resonator.

source, from which a current about 100 μ s long was gated to the simmered flashlamp by a giant power transistor (nominal parameters 300 A and 550 V). The voltage of the capacitor, 480 V maximum, was controlled by a constant-current switch-mode DC-to-DC converter. A 25 mA simmer (keep-alive) current was obtained from the capacitor using limiting resistors and a special diode arrangement. The simmer current was initiated automatically by a low power 10 kV voltage source on demand. The quasi-CW pumping method is suitable for mode-locking purposes, because a slow rise in the current with steady state end pumping can be obtained efficiently.

The pumping energy needed at the laser threshold with pure solvent in the mode-locking cell was 4.7 J. According to theory /2/, magnification of 2.75 corresponds to 27% equivalent mirror reflectivity ($2/M^2$). Mode-locking was obtained by pouring premixed Kodak 9860 solution into the dye reservoir and monitoring the output. The mode-locked pulse train was monitored by observing the reflection from the aperture plate. The pulse shape was not very stable. It sometimes contained large pulses and the success rate was about 50%. Addition of a LiF:F $_2^-$ crystal with about 90% initial transmission gave complete mode-locking with a success rate of 90%, Fig.2. The internal power level was lower because of intrinsic loss of the crystal. Operation with another mode-locking dye, Kodak 26, was less successful. LiF:F $_2^-$ material has a comparatively long relaxation time, almost 100 ns, and thus it is not alone suitable as

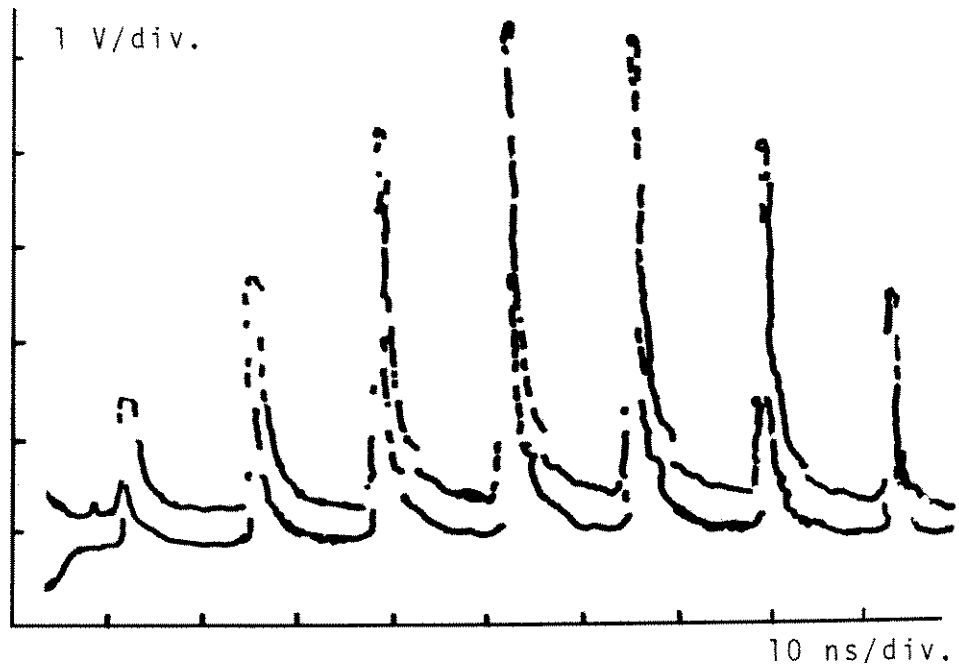

Fig. 2. Shape of the mode-locked pulse train inside a Nd:YAG laser using a self-filtering unstable resonator and dye and LiF:F₂ switches. The pulse shape was registered with a fast photodiode and Tektronix R 7912 oscilloscope (500 MHz bandwidth) and hand-copied from the screen (Metsähovi 2.9.1987).

a mode-locker in a resonator with a round-trip time of 13 ns. Still, some mode-locking-like operation was possible. The resonator was found to be insensitive to misalignment of the mirrors. The real use of this resonator requires an output coupling method, e.g. a scraper mirror /2/.

ACKNOWLEDGMENTS

The authors thank Professor T.T. Basiev, Institute of General Physics, Moscow, for supplying the LiF:F₂ crystal and the Hungarian Academy of Sciences and the Academy of Finland for research travel grants.

REFERENCES

1. J.J. Degnan, Satellite laser ranging: current status and future prospects. IEEE Trans. Geoscience and Remote Sensing GE-23,4(1985)398-413.
2. P.G. Gobbi, S. Morosi, G.C. Reali, and A.S. Zarkasi, Novel unstable resonator configuration with a self-filtering aperture: experimental characterization of the Nd:YAG loaded cavity. Appl. Opt. 24,1(1985)26-33.

3. A.V. Konyashchenko, I.V. Kryukov, P.G. Kryukov, and A.V. Sharkov, Passive switch with a mixture of saturable absorbers for mode locking in solid-state lasers. Sov. J. Quantum Electron. 17,4(1987)511-512.
4. I.M. Winer, Production of mode locked laser pulses in Nd:YAG using a glass filter absorber. Appl. Opt. 12, 12(1973)2809.
5. J. Chen, Mode locking of a Nd:glass laser with LiF:F₂⁻. Appl. Opt. 24,7(1985)1073-1075.
6. L.S. Kornienko, N.V. Kravtsov, V.A. Sidorov, A.M. Susov, and Yu.P. Yatsenko, Mode locking in a cw solid-state laser by a filter containing F₂⁻ centers. Sov. J. Quantum Electron. 15,11(1985)1566-1567.
7. V. Lupei, A. Lupei, V. Ionita-Manzatu, S. Georgescu, and F. Domsa, Combined mechanical-color center passive Q-switching of neodymium lasers. Opt. Comm. 48,3(1983) 203-206.
8. T.T. Basiev, I.Ya. Itskhoki, B.G. Lysoi, S.B. Mirov, and O.B. Cherednichenko, Pulsed YAG:Nd³⁺ laser with passive Q switch in the form of an LiF crystal containing F₂⁻ centers. Sov. J. Quantum Electron. 13,3(1983)370-372.

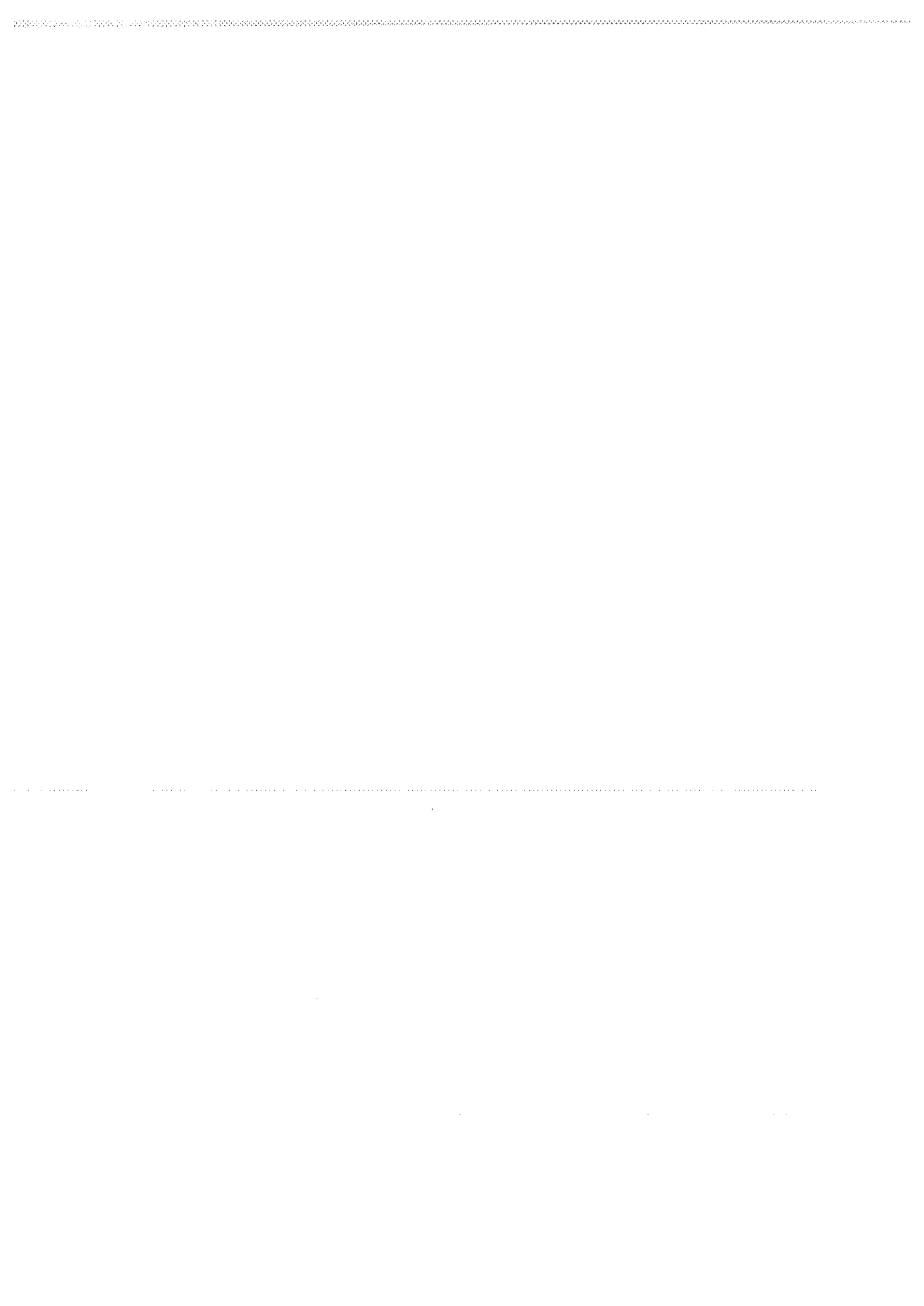

CAVITY DUMPING OF A MODE-LOCKED SELF-FILTERING
UNSTABLE RESONATOR Nd:YAG LASER

Matti Paunonen

Finnish Geodetic Institute
Ilmalankatu 1A
SF-00240 Helsinki, Finland

Telephone: 358-0-264994
Telefax: 358-0-414946
Telex: 19207310
Earn/Bitnet: Geodeet@Finfun

Abstract. The cavity dumping operation of a pulsed, air cooled, passively mode-locked Nd:YAG laser with a self-filtering unstable resonator is described. Single pulses with 10-15 mJ energy and 0.5 mrad beam divergence were obtained. The pumping energy was 14 J and the repetition rate 1 Hz.

1. INTRODUCTION

The development of a mode-locked laser reported in a companion paper /1/ was continued by adding an internal switchout device, generally known as a cavity dumper or by the system name, pulse transmission mode laser. The cavity dumping method yields several times higher energy than that usually obtained through the partially reflecting mirror or other type of output coupling element. The required pumping energy is also the lowest possible owing to the high reflectivity of the mirrors (practically 100%). The operating voltage of the Pockels cell affecting the cavity dumping is two times lower than that required in external pulse selection. A single pulse, rather than the pulse train typically obtainable from a mode-locked laser, is generally used in satellite laser ranging.

2. EXPERIMENTAL SETUP

The optical layout of the cavity dumped version of the developed passively mode-locked Nd:YAG laser with a self-filtering unstable resonator is shown in Fig.1./1/. A Pockels cell (Gsänger LM7, aperture 7 mm and nominal quarter wave voltage 3 kV) and a thin film polarizer (CVI) were added to the original resonator. Initially the Pockels cell is unenergised and has only a passive effect on the laser beam. When a quarter wave voltage is switched onto the Pockels cell, the incoming plane polarized beam from the mirror M1 will be converted to circular polarization. After returning from mirror M2 and passing the Pockels cell a second time, the polarization is again planar but rotated by 90 degrees. Thus the beam is reflected out of the resonator at the polarizer.

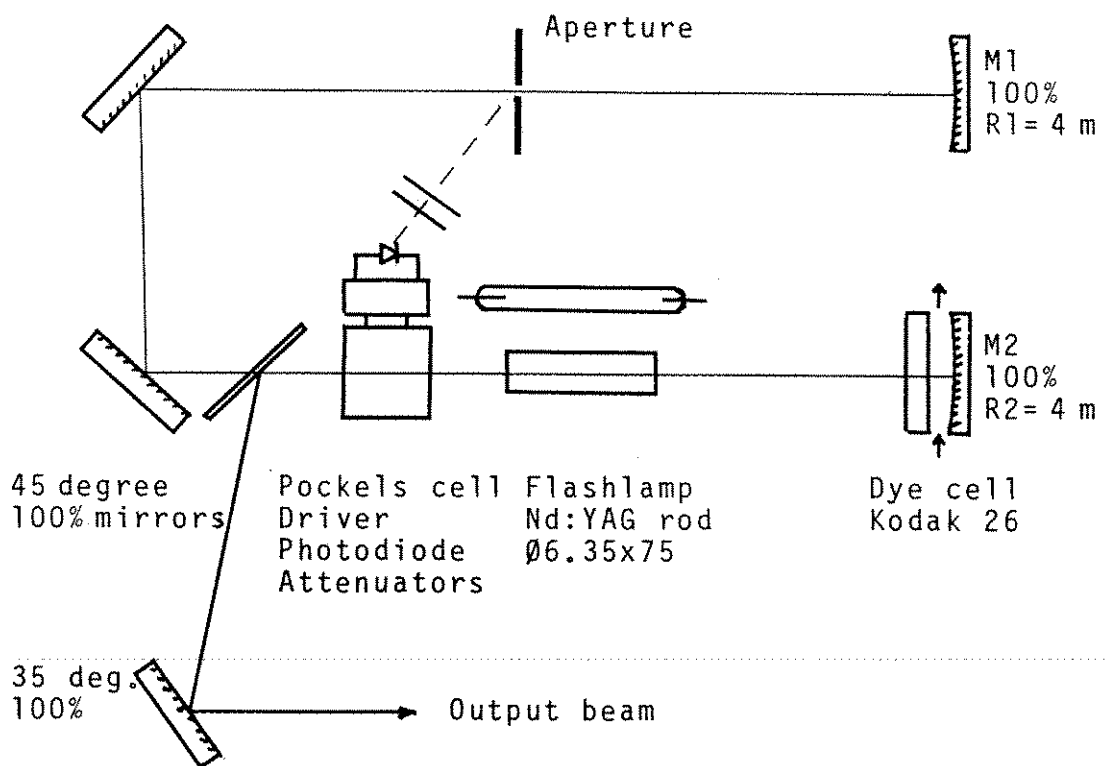

Fig.1. Optical layout of a cavity dumped passively mode-locked Nd:YAG laser with a self-filtering unstable resonator.

A standard avalanche transistor stack was used to switch a voltage of 3.5 kV onto the Pockels cell /2-3/. The stack consisted of 11 selected small transistors 2 N 5551 (Motorola) connected in series. To damp oscillations, a series resistor of 100 ohm was added. The rise of the internally circulating mode-locked pulse was detected with a fast photodiode (Siemens BPX 65) looking the attenuated reflection from the aperture plate. The trigger level of a

fast comparator (Plessey SP 9685) was adjustable to facilitate switchout at the peak of the internal power. The small level trigger pulse is amplified to 10 V and fed to the base of the lowest transistor in the stack through a cable of suitable length. The delay in switching from the low level trigger to the high voltage pulse is 7 ns and the rise time of the high voltage pulse is 5 ns.

The mode-locking dye was altered to Kodak 26 /4/ with 1,2-dichloroethane solvent and the concentration was increased to produce about 40% transmission.

The pumping energy taken from the energy storage capacitor was 14 J at the operating level, corresponding to about 280 A in 120 μ s pulse./5/. The repetition rate was 1 Hz, but the even higher rate of 1.5-2 Hz could also be used. The use of quasi-CW pumping (i.e. a nearly rectangular pulse) facilitates an easy search for optimum alignment of the mirrors: adjust until the earliest appearance of the laser pulse. The pumping pulse can then be shortened to save the trailing energy otherwise lost.

3. RESULTS AND DISCUSSION

A reflection from the aperture plate without cavity dumping action is shown in Fig.2a and a dumped pulse in Fig.2b. At the selected operating level a train of five larger pulses was generated. The clearly visible prepulse seemed to originate from reflection at the Pockels cell; at least the distance between the cell and mirror M2 corresponds to the time difference. When an earlier trigger point was selected, no prepulse was discernible, but a trailing pulse at about 5% level and at 13 ns distance was found. The output energy was measured with a calibrated pyroelectric energy detector (Gentec 100A) using the reflection method. The single output energy was in the range 10-15 mJ. The beam divergence, measured from the burn spots at different distances, was found to be about 0.5 mrad. The burn pattern was very regular. The power was sufficient to create a spark in the air at the focus of the 10 cm lens. A second harmonic formation to 532 nm was tested with a 30 mm long II type KD*P crystal (Quantum Technology). The conversion efficiency measured was about 40%, which is plausible owing to the good beam properties and the high power density, over 2 GW/cm². No facilities for measuring the pulse duration were at hand, but on the basis of reports in the literature it is thought to be under 50 ps. Thus the peak power of a single pulse is estimated to be over 200 MW.

Further construction of the system includes the addition of a double pass amplifier. Also the problem of the stray pulse must be solved. An optical isolator may be useful between the oscillator and the amplifier. Eventually 100 mJ output energy in green is expected. Optical components can be mounted on a plate measuring 300 mm by 1700 mm. The size of the common power supply is about 250 mm (W) by 500 mm (L) by 150 mm (H).

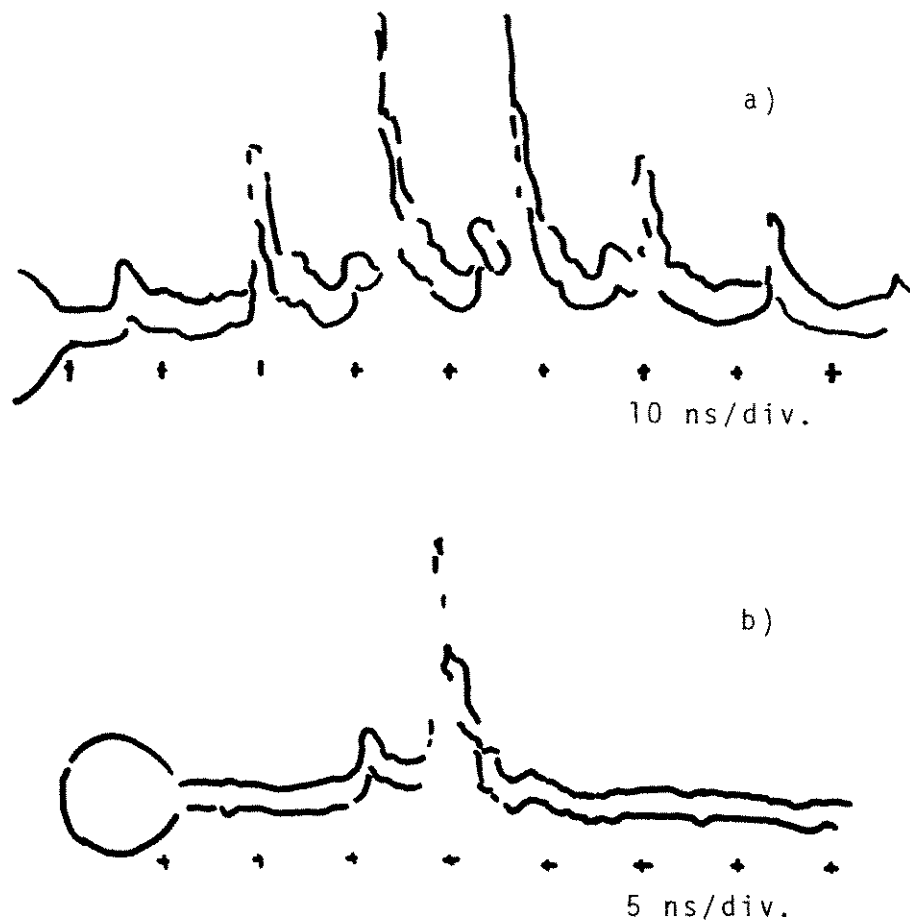
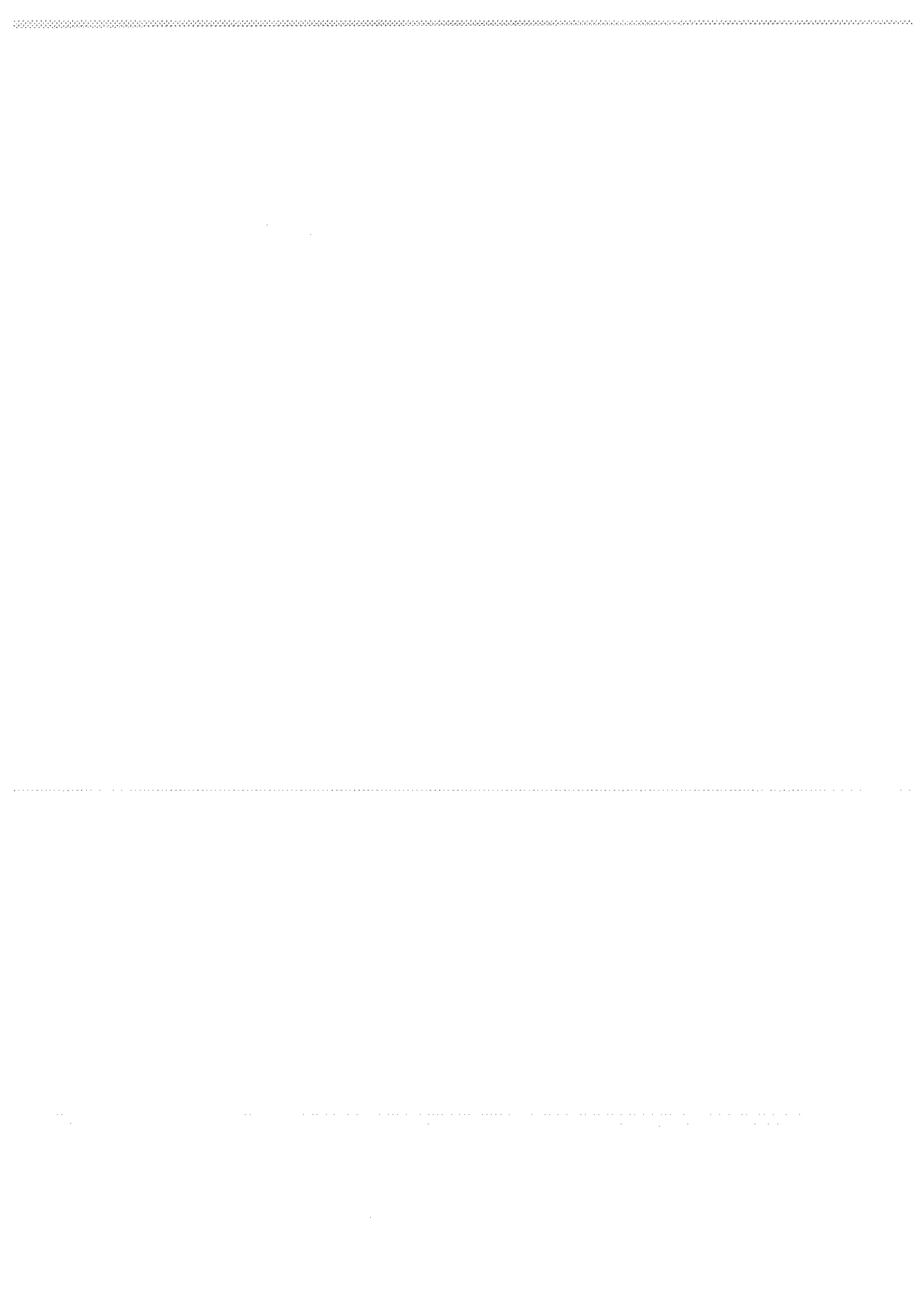

Fig.2. a) Shape of the mode-locked pulse train (i.e. a pulse circulating in the resonator) without cavity dumping operation. b) Cavity dumped pulse. The shape was registered with a fast photodiode and Tektronix R 7912 Transient digitizer, 500 MHz bandwidth, and hand-copied from the screen.

REFERENCES

1. M. Paunonen, I. Kertész, A mode-locked Nd:YAG laser using a self-filtering unstable resonator and passive co-operative dye and LiF:F₂⁻ switches. Paper presented at the 7th International Workshop on Laser Ranging Instrumentation, 2-6 Oct., 1989, Matera, Italy.
2. S.J. Davis, J.E. Murray, D.C. Downs, W.H. Lowdermilk, High performance avalanche transistor switchout for external pulse selection at 1.06 μm . Appl. Opt. 17, 19(1978)3184-3186.
3. M. Glotz and H-J. Eichler, Cavity dumping of a mode-locked pulsed Nd:YAG laser. J. Phys. E: Sci. Instr. 20(1987)1493-1496.

4. N.H. Schiller, M. Foresti, and R.R. Alfano, Picosecond pulses produced by mode locking a Nd:glass laser with Kodak dye #26. J. Opt. Soc. Am. B. 2,5(1985)729-731.
5. M. Paunonen, An air-cooled simmered Q-switched Nd:YAG laser with transistor-gated flashlamp pulsing. Conference on Lasers and Electro-optics (CLEO'84), 18-21 June 1984, Anaheim, California, Digest, pp. 34-36.



7th International Symposium on Laser Ranging Instrumentation
Matera, Italy October 2-6, 1989

**Powerful picosecond pulses from a mode-locked
SFUR Neodimium laser for laser ranging.**

G.Gabetta*, K.Hamal**, H.Jelinkova**, J.Marek**, G.C.Reali*, P.Valach**

* Univ. of Pavia, Depart. of Electronics
Via Abbiategrasso 209, 27100 Pavia, Italy
phone +39 382 391212
telefax +39 382 422881

**Czech Technical Univ., Faculty of Nucl. Sciences and Phys. Eng.
Brehova 7, 115 19 Prague, Czechoslovakia

Abstract.

A Self-Filtering Unstable Resonator in a modified configuration, loaded with Nd:YAG or Nd:YAP active medium, was used for generating powerful, passively mode-locked picosecond pulses. Typical figures are: >30/20 mJ single pulse energy, 25/15 ps pulse duration for YAG and YAP, respectively. Pulse energy and duration, and high optical beam quality make this system very interesting for laser ranging.

1. Introduction.

Gobbi and Reali¹ introduced the Self-Filtering Unstable Resonator (SFUR) as an improved resonant cavity for extracting energy from high-gain laser systems in the form of a low-divergence beam.

Given the high beam quality and the possibility, already demonstrated, of very efficient mode-locking operation using the SFUR², we started an experimental investigation of picosecond high energy pulse generation in Nd:YAG or Nd:YAP active media, having in mind scientific and applied utilizations such as laser radar transmitters, lidars, et cetera.

We report here the main results of our investigation.

2.Theory.

The SFUR is a negative branch confocal unstable resonator in which a filtering aperture is placed at the common focal plane of the mirrors. Since the aperture clips energy from the beam in both forward and backward directions, this two way clipping reshapes the beam to give it a very smooth profile when a particular choice of aperture size is made. The SFUR operating principle is that the aperture radius, a , is chosen to be located at the first zero in the far field Airy pattern of the aperture as focused by the shorter focal length mirror, f_1 . That is, $a = (0.61\lambda f_1)^{1/2}$, where λ is the operating wavelength of the laser. In this way, the double sided clipping at the limiting aperture creates a nearly first Airy disk shaped beam in the half rountrip through mirror f_1 . In the other half rountrip the beam gets magnified by the longer focal length mirror f_2 and eventually outcoupled by some of the standard means. In the modified nonconfocal SFUR^{3,4} (fig.1), the recollimating mirror f_2 is replaced by a longer focal length mirror (flat, in our case), which allows a shorter cavity for the same magnification. A simple computation of the ray transfer ABCD matrix for this case immediately uncovers that the self-imaging condition, $B=0$, is satisfied at a slightly displaced position $\Delta=L_1-f_1$ with respect to the f_1 focal plane. The aperture is thus placed at this new position, and, accordingly, resized to $a = (0.61\lambda(2-L_1/f_1)L_1)^{1/2}$. In this configuration the beam is divergent at the output, but it can be easily recollimated with a lens, compensating for its pure geometrical divergence.

The mode-locking working conditions of the modified SFUR have been chosen with the help of two programs simulating the dynamic evolution of the mode-locking inside the laser cavity. These programs have been developed with the aim of getting qualitative answers about the values of few input engineering parameters, from which we could refine the tune up by experimental trial-and-error.

The first program implemented the Glenn model⁵, modified to take into account the high concentrated losses in our resonator. The second, beam propagation program, starting from a guessed time duration of the pulses at the onset of the nonlinear phase in the mode-locking development, tries to use the informations obtained from the first one to estimate the maximum pulse shortening with the considered active medium.

3. Experimental results.

We evaluated the mode-locking performances of a modified SFUR, with a flat mirror f_2 , and a feedback mirror with $f_1=250$ mm.

The overall length of the resonator was 1240 mm, and the L_1 calculated from the theory turned out to be 280 mm. The resonator magnification was $M=-7.4$.

The oscillator, operating at 1 Hz, was loaded alternatively with either a 7 mm x 115 mm, Nd:YAG or Nd:YAP active rod by Monokrystaly Turnov (Czechoslovakia), of which only 75 mm were pumped in a house made, elliptical, silver plated pumping chamber.

The output coupling was through a scraper mirror, coated for very high (nearly 100%) reflectivity at $\lambda=1$ μm , in which the 0.8 mm diameter aperture was mechanically drilled.

In the experiments we used a 5 mm thick, Brewster angled dye cell, placed very near the mirror f_1 . Passive mode-locking was achieved using ML51 dye dissolved in dichlorethane at various concentrations. As these were varied, the number of pulses in the mode-locked train decreased, reaching the number of 3 at a concentration corresponding to a low signal transmission of 3% and 2% for YAG and YAP, respectively. At this concentrations, over 60 mJ and 40 mJ output energies were obtained for the two cases. The energy was always distributed in the 3

pulses, with more than 50% of it appearing in the highest one.

The time durations were measured by a Hadland Imacon 500/PV001 streak camera, resulting in 24 ± 9 ps and 15 ± 4 ps for YAG and YAP, respectively.

We have been very careful in determining the beam shapes of the generated pulses in near, intermediate and far field. These were detected by a CCD camera connected through a video grabber to a personal computer. The real time acquisition and software processing of the pulses allowed to optimize the alignment of the resonator, and the beam profile through the fine tuning of both the aperture radius and positioning. Under the extreme conditions, as described here, it was very important to be able to display both contour and 3D profiles to convey as much information as possible on both smoothness and symmetry of the generated beam.

Fig. 2 shows the near-field profile of the well aligned, passively mode-locked SFUR, taken just after the beam has been reflected out by the scraper mirror. The 3D map evidences the smoothness of the beam tails, which is also helped by some reshaping action of the dye, while the symmetry is better appreciated on the contour map.

Figure 3 shows the far-field profile of the SFUR beam at the focus of a 2 m focal length lens. About 80% of the energy was found within 0.8 mrad full angle divergence, in good agreement with the predicted divergence of the resonator.

Finally, working for several days with the oscillator loaded with both the active media, alternatively, we never recorded damage to anyone of the optical components in the resonator. This is also indicative of the good optical quality of the generated beam.

We believe that the optical quality of the generated beam is the most striking performance of this laser system, especially in consideration of the extreme compressed dynamics of the mode-locking development.

4. Conclusions.

We have reported the results of a modified SFUR oscillator, loaded with both Nd:YAG and Nd:YAP, operating in passive mode-locking. The results demonstrate that the SFUR is a very efficient cavity design for short, high energy pulse generation. The most interesting figure of the

resonator still remains the high optical quality of the generated beam. It should be noted that this can be even better using polarization coupling, whenever this is allowed⁷.

The overall fluctuation (fluctuation of the highest pulse in the train, as recorded by a transient digitizer with resolution better than 2 ns) of the passive mode-locking was not less than 20%. The same system, operated in active-passive mode-locking, had a much better stability, with fluctuation of less than 4%.

Furthermore, the system has been proved to be rather insensitive to mechanical and thermal perturbations, maintaining good alignment over days of operation.

In conclusion, we believe that this system has a high potentiality in the laser ranging applications where short pulses, beam quality, efficiency and compactness, and alignment and pointing stability are all together requirements.

References.

- 1 P.G.Gobbi, G.C.Reali, Opt. Comm., 52, 195, 1984
- 2 P.G.Gobbi, S.Morosi, G.C.Reali, A.S.Zarkasi, Appl. Opt., 24, 26, 1985
- 3 A.Bianchi, A.Ferrario, P.G.Gobbi, C.Malvicini, G.C.Reali, SPIE Proc., 701, 132, 1987
- 4 P. Di Lazzaro, T.Hermsen, C.E.Zheng, IEEE Jour. Q.E., QE-24, 1543, 1988
- 5 W.H.Glenn, IEEE Jour. Q.E., QE-11, 8, 1975
- 6 K.Hamal, V.Hruskova, H.Jelinkova, CLEO '85 Proc., 82, WE4
- 7 P.G.Gobbi, G.C.Reali, SPIE Proc., 540, 119, 1985

Figure Captions.

- 1 Schematic of the modified SFUR.
- 2 3D and contour plots under the mode-locked operation at the highest energy output. Near-field just after the beam has been coupled out by the scraper mirror.
- 3 3D and contour plots under the mode-locked conditions as in fig.2. Far-field at the focus of a 2 m focal length lens.

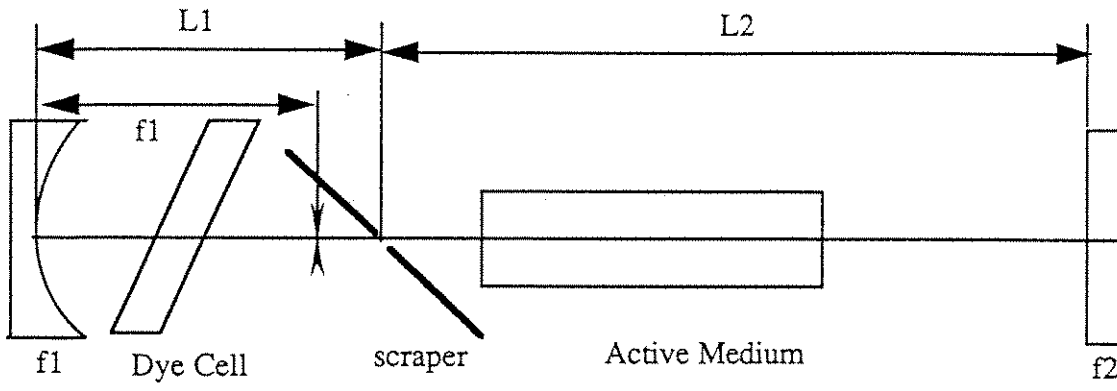

Fig. 1

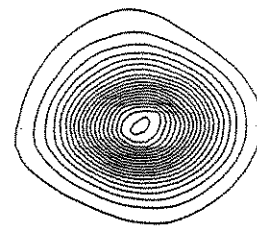
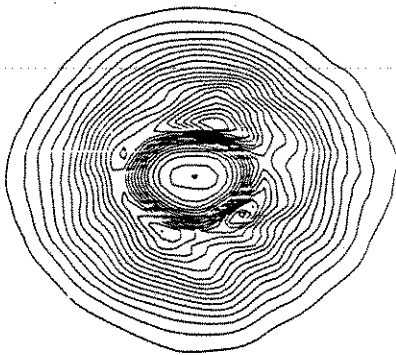
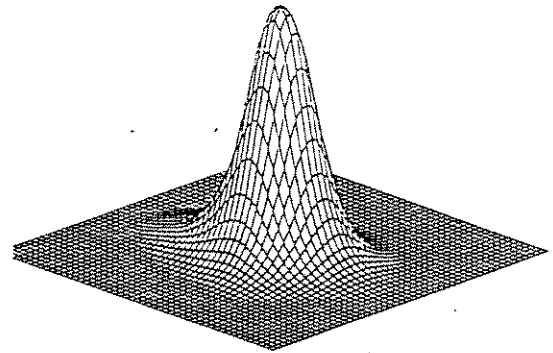
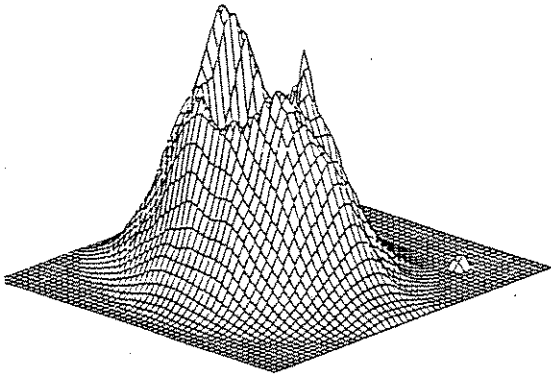

Fig. 2

Fig. 3

COMPACT AND RELIABLE SFUR MODE-LOCKED ACTIVE-PASSIVE
Nd:YAG LASER FOR SATELLITE RANGING.

C. Malvicini, A. Ferrario
QUANTA SYSTEM Srl - Via Venezia Giulia 18, 20157 Milano - Italy

G. Gabetta, G.P. Banfi, G.C. Reali
UNIVERSITY of PAVIA, Via Abbiategrasso 209, 27100 Pavia - Italy

Abstract

We have developed a new 10 Hz picosecond mode-locked active-passive Nd:YAG laser based on a Self Filtering Unstable Resonator.

Pulse energies up to 70 mJ in 30 ps and 200 mJ in 100 ps at 1.06 μm have been achieved with high efficiency in a compact oscillator-amplifier configuration.

Introduction

Time resolved LIDAR and transportable laser ranging stations require the development of efficient, compact and reliable solid state lasers emitting high energy picosecond pulses.

Pulsed mode-locked lasers have been designed for many years with a stable TEM₀₀ oscillator. In this approach the small mode diameter, about 1-1.5 mm, involves a single pulse energy typically of about 1 mJ, so that several amplifiers are usually required to reach useful energy levels.

The positive-branch unstable resonator with a radially-variable reflectivity mirror shows large mode size and near diffraction-limited output beam with smooth profile. The performances have been experimentally demonstrated for Q-switched and feasible for active-active mode-locked laser. However in active-passive mode-locking laser the presence of saturable absorber reduces the output beam size due to the higher saturation in the central part of the beam [1].

A considerable improvement in the performances has been obtained using a Self-Filtering Unstable Resonator (SFUR) [2], [3],[4], with the following advantages:

- large mode diameter
- high beam quality
- small illuminated area in the dye cell

SFUR theory.

The SFUR is a negative-branch unstable resonator with a suitable mode-shaping aperture A set at the internal focal plane, at distance L_f from M1 (Fig. 1). The resonator supports a spherical wave which is clipped by the aperture and then focused by the shortest curvature radius M1 on the aperture itself, generating an Airy pattern (far field diffraction of the aperture). The aperture diameter D is chosen (SFUR condition) so that only the central lobe propagates toward M2 and grows in size due to diffraction. The beam returned to the aperture is smooth, nearly gaussian and reaches a nearly zero intensity at a diameter $\approx 1.5 MD$, where M is the geometrical resonator magnification. Typical magnification values to fill the rod diameter are 4-7x. The aperture also gives a strong spatial filtering at each round-trip of any beam perturbation and cools down the intensity in the internal focal plane avoiding hot spots.

In the general case the geometrical magnification for a SFUR resonator is given by

$$M = g - \sqrt{(g^2 - 1)}$$

where

$$g = 2g_1 g_2 - 1$$

and g_1 , g_2 , including the rod thermal lens F_t , are:

$$g_1 = 1 - L_o/R_1 - L_2/F_t$$

$$g_2 = 1 - L_o/R_2 - L_1/F_t$$

with

$$L_o = L_1 + L_2 - L_1 L_2/F_t$$

All lengths are effective lengths for transverse mode propagation (geometrical lengths divided by the corresponding refractive indexes).

The distance L_f between M_1 and the focal point (aperture position) is given by

$$1/L_f = 1/R_1 + \sqrt{(g^2 - 1)/2g^2 L_0}$$

The optimum aperture diameter is

$$D = \sqrt{(2.44 \lambda B_1)}$$

where

$$B_1 = 2 L_f (1 - L_f/R_1)$$

is the B element of the ABCD matrix for ray transfer from the aperture to M_1 and back to the aperture.

The radius of curvature R_a of the large beam reaching the aperture is

$$R_a = 1/(2/R_1 - 1/L_f) - L_f$$

In general this beam is not collimated, so that the beam size in the rod is not the same as on the aperture and the diameter is approximately given by

$$1.5 M D (1 - (L_1 - L_f)/R_a)$$

The SFUR round-trip losses are approximately $M^2/2$. An high magnification value, as typical in SFUR, is assumed in above formulas.

Experimental arrangement and results.

The experimental arrangement is illustrated in Fig. 2. The system consists of a SFUR oscillator with a 7 mm diameter Nd:YAG rod, one amplifier and harmonic generators. Mode-locking was achieved by flowing dye Kodak 9740 against mirror M_1 , in a 1 mm thick cell. An acousto-optic standing-wave modulator driven at 50 MHz RF was placed near the dye cell to improve mode-locking stability.

The SFUR aperture was drilled in a thin metallic plate. The selected single-pulse was cavity-dumped by means of a polarizer and a Pockels cell. Spurious reflection (a few percent) of horizontal polarization was blocked by a crossed polarizer outside the cavity, increasing the single-pulse contrast, and it was monitored by a photodiode to trigger the high voltage step to the Pockels cell. The extracted single-pulse, with vertical polarization, was then sent to the amplifier and to the harmonic generators.

The resonator magnification was $M \approx -8$, obtained with $R_1 = 34.6$ cm (effective value taking into account the dye solution refractive index), $R_2 = 5$ m and $F_t \approx 7$ m (25 J pump energy at 10 Hz repetition rate). The aperture diameter was $D = 0.7$ mm and $L_f \approx 18$ cm.

The rod was quite close to mirror M2 ($L_2 = 22$ cm) so that the two opposite beams through it had similar sizes. By this way selffocusing effects were minimized and the high quality output beam allowed reliable amplification. The beam diameter in the rod was calculated to be about 6.5 mm at near zero intensity, ensuring good filling factor, while avoiding beam clipping which would generate diffraction rings.

First the oscillator was operated without intracavity etalon and with a quarter wave plate replacing the Pockels cell, out coupling the full mode-locking train.

Reliable dye bleaching and stable mode-locking was obtained with a dye concentration corresponding at about 1.3 X increase of threshold pump energy. The train contained five pulses at envelope FWHM, with 15 mJ in the highest pulse from the oscillator.

The temporal pulse structure was analyzed using a streak-camera revealing a near gaussian pulse shape with a FWHM pulse-width in the range 18 ± 25 ps.

With a standard, not wedged, Pockels cell mounted in cavity, realizing the single pulse cavity-dumping, streak camera measurements showed a pulse-width of 40 ps.

Furthermore in a significative fraction of the output pulses we observed satellites with time separation of 150 ps about or multiples, caused by etalon effect in the Pockels cell crystal.

This problem was then solved using a wedged Pockels cell, obtaining pulses free of satellites. Single pulse contrast was of 50 at 10 Hz and 100 at 1 Hz.

Introducing etalons in the cavity it was possible to obtain longer pulsewidths, with a regular temporal shape. Fig.3 shows typical results obtained with a 3 mm uncoated sapphire etalon positioned at different tilt angles.

The dye concentration was then increased up to obtain 40 mJ in a single extracted pulse from the oscillator, with an amplitude stability of $\pm 5\%$.

The oscillator output beam, expanded and collimated with a telescope, was then amplified in a 9.5 mm rod. The oscillator beam was slightly oversized in order to provide nearly uniform amplifier illumination. Single pulse energy of 70 mJ in 30 ps and 200 mJ in 100 ps has been obtained.

Conclusions.

We have realized a picosecond Nd:YAG laser operating in active-passive mode-locking regime, emitting single pulses of 100 ps of duration and 200 mJ of energy, utilizing only two laser heads. A compact, rugged and efficient system has been obtained seeming an ideal solution for transportable laser ranging stations.

References

- 1) A. Chandonnet, K.J. Snell, M. Pliche', N. McCarthy and P. Lavigne (*); "Fundamental mode operation of a pulsed Nd:YAG laser with a variable reflectivity mirror"; LROL Dep. de Physique, Universite' Laval, Quebec, Canada, G1K7P4; (*) Institut National d'Optique, C.P.9970, Sainte-Foy, Quebec, Canada, G1V4C5.
- 2) P.G. Gobbi, G.C.Reali, Opt. Comm. 52, p195, 1984
- 3) P.G. Gobbi, S. Morosi, G.C. Reali, A.S. Zarkasi, Appl. Opt. 24, p26, 1985.
- 4) A. Bianchi, A. Ferrario, P.G. Gobbi, C. Malvicini, G.C. Reali, SPIE Proc. 701, p132, 1987.

BASIC COMPONENTS OF A SFUR RESONATOR

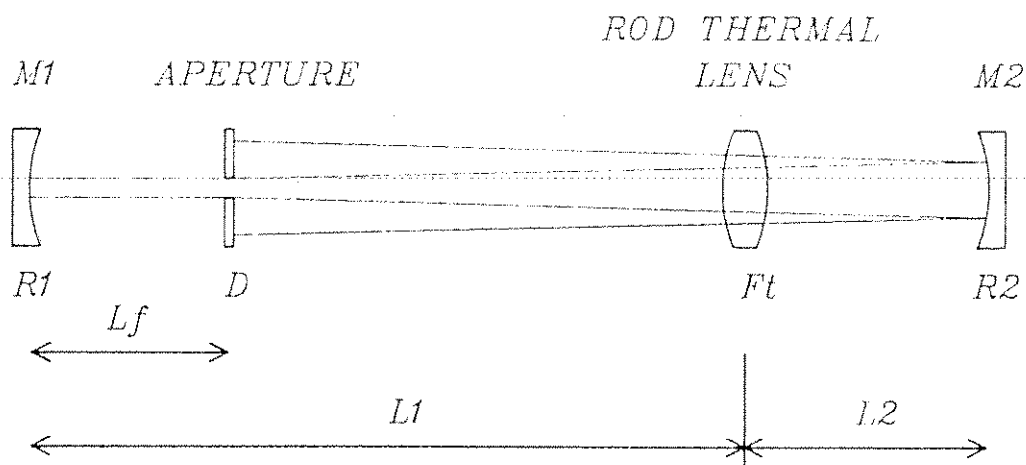

Fig. 1 - SFUR resonator diagram

SFUR ACTIVE-PASSIVE MODE-LOCKED OSCILLATOR PLUS AMPLIFIER

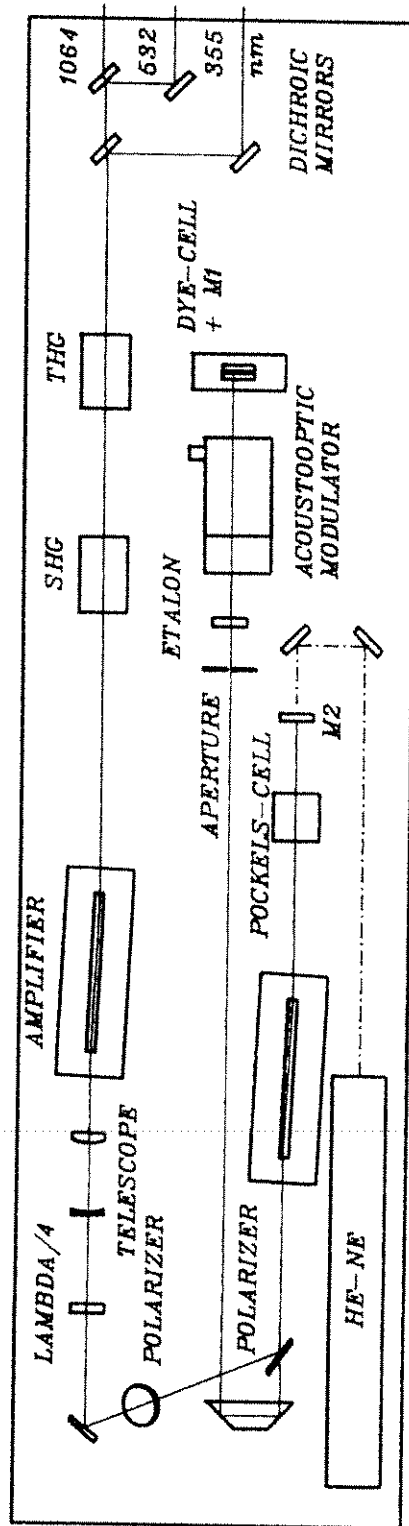

Fig. 2 - Experimental laser configuration.

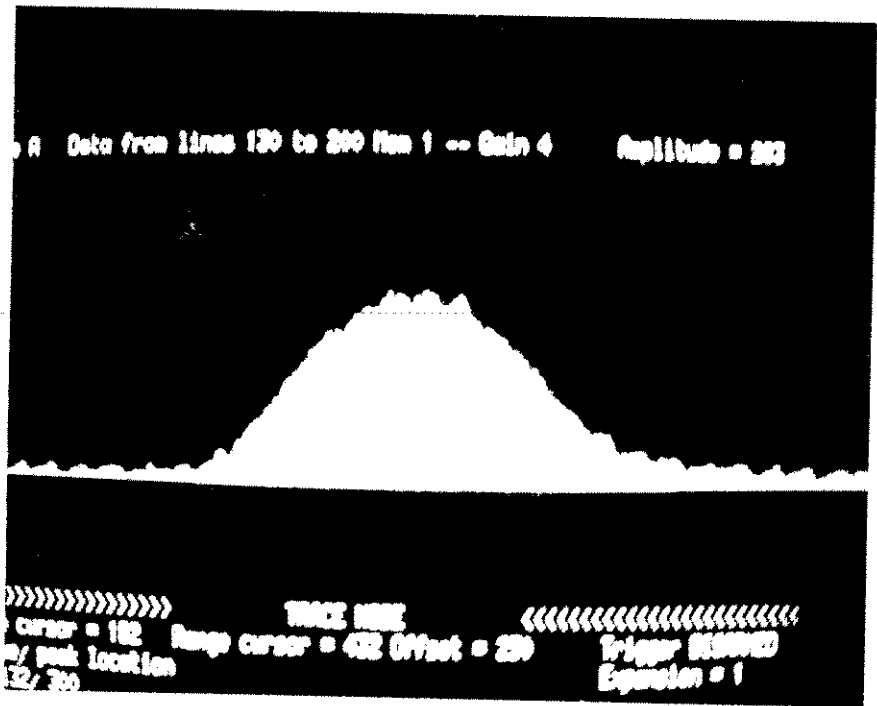
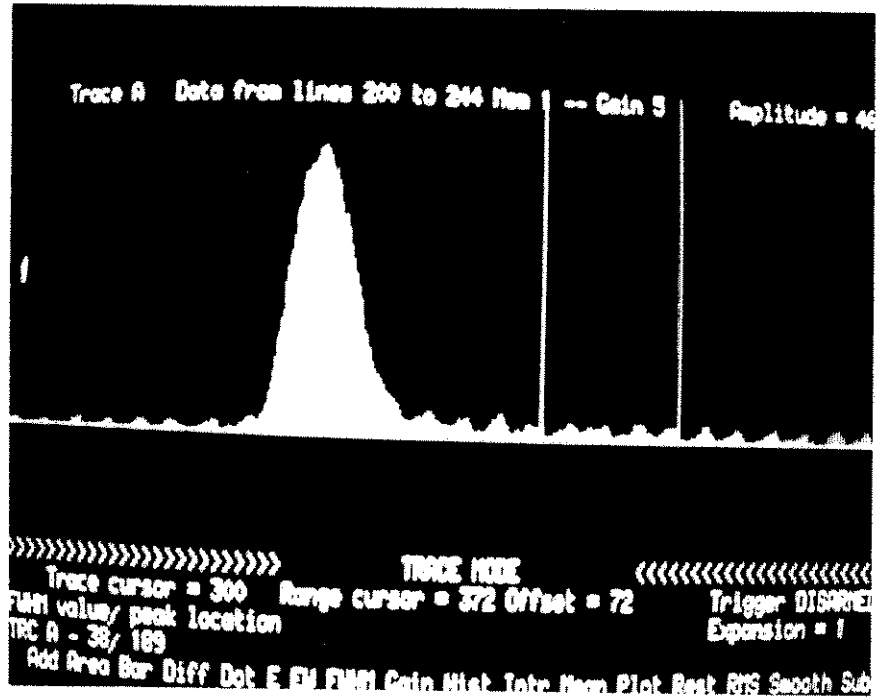

Fig. 3 - Streak camera measurements at different etalon tilt angle. FWHM pulse-widths are 53 ps and 180 ps. For reference the two vertical cursor lines are 100 ps separated in time.

